



1-800-968-8604

Extinguishing mediocrity online since 1999

Wolf Steel Ltd.

24 Napoleon Road, Barrie, Ontario Canada, L4M 0G8

INSTALLATION INSTRUCTIONS

HIGH EFFICIENCY AIR HANDLERS

1.5-5 Tons

FEATURING R-410A OR R22 REFRIGERANT

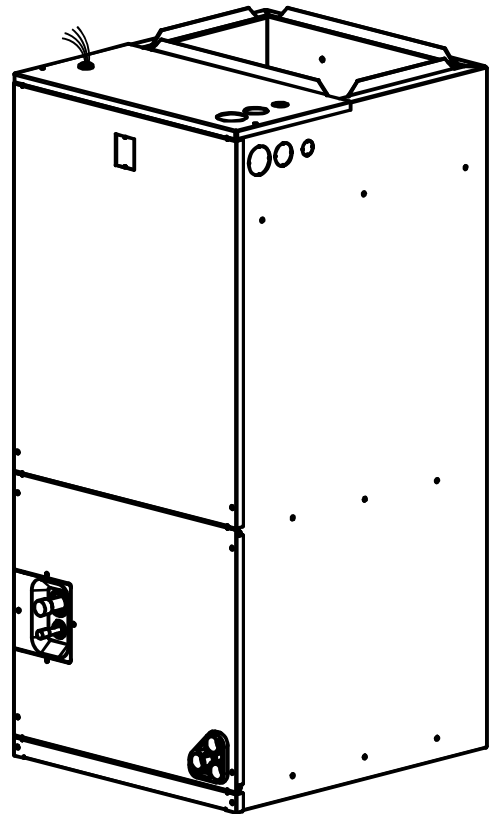

RECOGNIZE THIS SYMBOL AS AN INDICATION OF IMPORTANT SAFETY INFORMATION

WARNING

These instructions are intended as an aid to qualified licensed service personnel for proper installation, adjustment and operation of this unit. Read these instructions thoroughly before attempting installation or operation. Failure to follow these instruction may result in improper installation, adjustment, service or maintenance possibly resulting in fire, electrical shock, property damage, personal injury or death.



DO NOT DESTROY THIS MANUAL

Please read carefully and keep in a safe place for future reference by a serviceman.

TABLE OF CONTENTS

1.0 SAFETY	3
2.0 GENERAL	5
2.1 UNIT DIMENSIONS.....	6
3.0 APPLICATIONS	7
3.1 VERTICAL UPFLOW.....	7
3.2 VERTICAL DOWNFLOW.....	7
3.3 HORIZONTAL.....	8
3.4 INSTALLATION IN AN UNCONDITIONED SPACE.....	10
4.0 ELECTRICAL WIRING	10
4.1 POWER WIRING.....	10
4.2 CONTROL WIRING.....	11
4.3 GROUNDING.....	11
4.4 ELECTRICAL DATA.....	12
5.0 AIRFLOW PERFORMANCE	12
6.0 DUCTWORK	15
7.0 REFRIGERANT CONNECTIONS	16
7.1 CONDENSATE DRAIN TUBING.....	16
8.0 AIR FILTER (not factory-installed)	17
9.0 FILTER INSTALLATION DIMENSIONS	18
10.0 WIRE DIAGRAM	19

This document is customer property and is to remain with this unit. These instructions do not cover all the different variations systems nor does it provide for every possible contingency to be met in connection with installation. All phases of this installation must comply with NATIONAL STATE AND LOCAL CODES. If additional information is required please contact your local distributor.

1.0 SAFETY





This is a safety alert symbol. When you see this symbol on labels or in manuals, be alert to the potential for personal injury.



This is an attention alert symbol. When you see this symbol on labels or in manuals, be alert to the potential for personal injury.

	WARNING
Disconnect all power to unit before installing or servicing. More than one disconnect switch may be required to de-energize the equipment. Hazardous voltage can cause server personal injury or death.	

	WARNING
If removal of the blower assembly is required, all disconnect switches supplying power to the equipment must be de-energized and locked (if not in sight of unit) so the field power wires can be safely removed from the blower assembly. Failure to do so can cause electrical shock resulting in personal injury or death.	

	WARNING
Because of possible damage to equipment or personal injury, installation, service, and maintenance should be performed by a trained, qualified service personnel. Consumer service is recommended only for filter cleaning / replacement. Never operate the unit with the access panels removed.	

	WARNING
These instructions are intended as an aid to qualified, licensed service personnel for proper installation, adjustment and operation of this unit. Read these instructions thoroughly before attempting installation or operation. Failure to follow these instructions may result in improper installation, adjustment, service or maintenance possibly resulting in fire, electrical shock, property damage, personal injury or death.	



WARNING

The unit must be permanently grounded. Failure to do so can result in electrical shock causing personal injury or death.



WARNING

PROPOSITION 65: This appliance contains fiberglass insulation. Respirable particles of fiberglass are known to State of California to cause cancer.

All manufacturer products meet current federal OSHA Guidelines for safety. California Proposition 65 warnings are required for certain products, which are not covered by the OSHA standards.

California's Proposition 65 requires warnings for products sold in California that contain or produce any of over 600 listed chemicals known to the State of California to cause cancer or birth defects such as fiberglass insulation, lead in brass, and combustion products from natural gas.

All "new equipment" shipped for sale in California will have labels stating that the product contains and /or produces Proposition 65 chemicals. Although we have not changed our processes, having the same label on all our productd facilitates manufacturing and shipping. We cannot always know "when, or if" products will be sold in the California market.

You may receive inquiries from customers about chemicals found in, or produced by, some of our heating and air-conditioning equipment, or found in natural gas used with some of our products. Listed below are those chemicals and substances commonly associated with similar equipment in our industry and other manufacturers.

Glass Wool (Fiberglass) Insulation
Carbon Monoxide (CO).
Formaldehyde
Benzene

More details are available at the websites for OSHA (Occupational Safety and Health Administration), at www.osha.gov and the State of California's OEHHA (Office of Environmental Health Hazard Assessment), at www.oehha.org. Consumer education is important since the chemicals and substances on the list are found in our daily lives. Most consumers are aware that products present safety and health risks, when improperly used, handled and maintained.



CAUTION

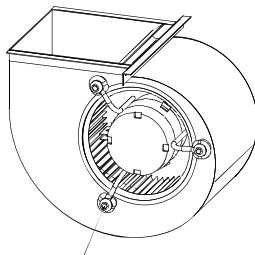

BLOWER MOTOR SHIPPING BOLT

Make sure the blower motor support is tight (3-motor mount bolts) then check to see if wheel is secured to motor shaft before operating unit.



WARNING

The first 6 inches of supply air plenum and ductwork must be constructed of sheet metal as required by NFPA 90B. The supply air plenum or duct must have a solid sheet metal bottom directly under the unit with no openings, registers or flexible air ducts located in it. If flexible supply air ducts are used they may be located only in the vertical walls of rectangular plenum, a minimum of 6 inches from the solid bottom. Metal plenum or duct may be connected to the combustible floor base, if not, it must be connected to the unit supply duct exposed to the supply air opening from the downflow unit. Exposing combustible (non-metal) material to the supply opening of a downflow unit can cause a fire resulting in property damage, personal injury or death.

Exception warning to downflow:

Installations on concrete floor slab with supply air plenum and ductwork completely encased must be not less than 2 inches of concrete (See NFPA 90A).

2.0 GENERAL

The unit can be positioned for bottom return air in the upflow position, left and right return in the horizontal position, top return in downflow position.

This Air Handler provides the flexibility for installation in any upflow or downflow horizontal application. The direct drive motors provides a selection of air volume to match any application. 3-Speed motors provide selections of air flow to meet desired applications.

Top and side power and control wiring, accessible screw terminals for control wiring all combine to make the installation easy, and minimize installation cost. Please contact your local distributor. See fig.1.

2.1 UNIT DIMENSIONS

NOTE: 25" CLEARANCE IS REQUIRED IN THE FRONT OF THE UNIT FOR FILTER AND COIL MAINTENANCE.

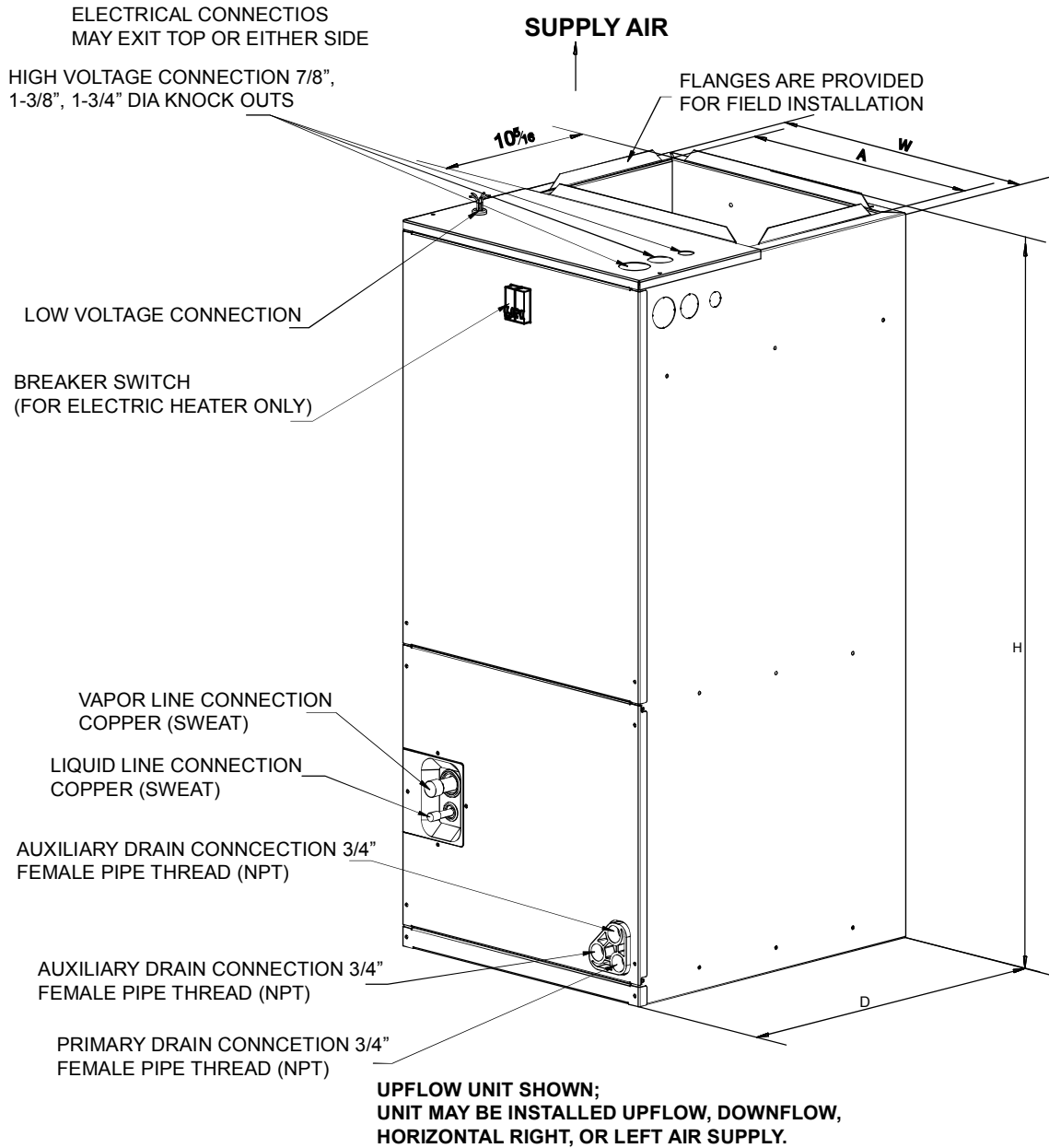

Fig.1 DIMENSIONS

DIMENSIONAL DATA

MODEL	Dimensions inch [mm]			
	UNIT HEIGHT "H" IN. [mm]	UNIT WIDTH "W" IN.[mm]	UNIT LENGHT "D" IN.[mm]	SUPPLY DUCT "A"
18/24/30	46-1/2"[1180]	19-5/8"[500]	20-5/8"[550]	18"[456]
36/42	54-1/2"[1385]	22"[560]	24"[610]	19-1/2"[496]
48/60	54-1/2"[1385]	22"[560]	24"[610]	19-1/2"[496]

3.0 APPLICATIONS

3.1 VERTICAL UPFLOW

- Vertical Upflow configuration is the factory set on all models (see Fig 1).
- If return air is to be ducted, install duct flush with floor. Use fireproof resilient gasket 1/8 to 1/4 in. thick between the ducts, unit and floor. Set unit on floor over opening.

IMPORTANT NOTE

Torque applied to drain connections should not exceed 15.ft.lbs.(see Fig.1&2)

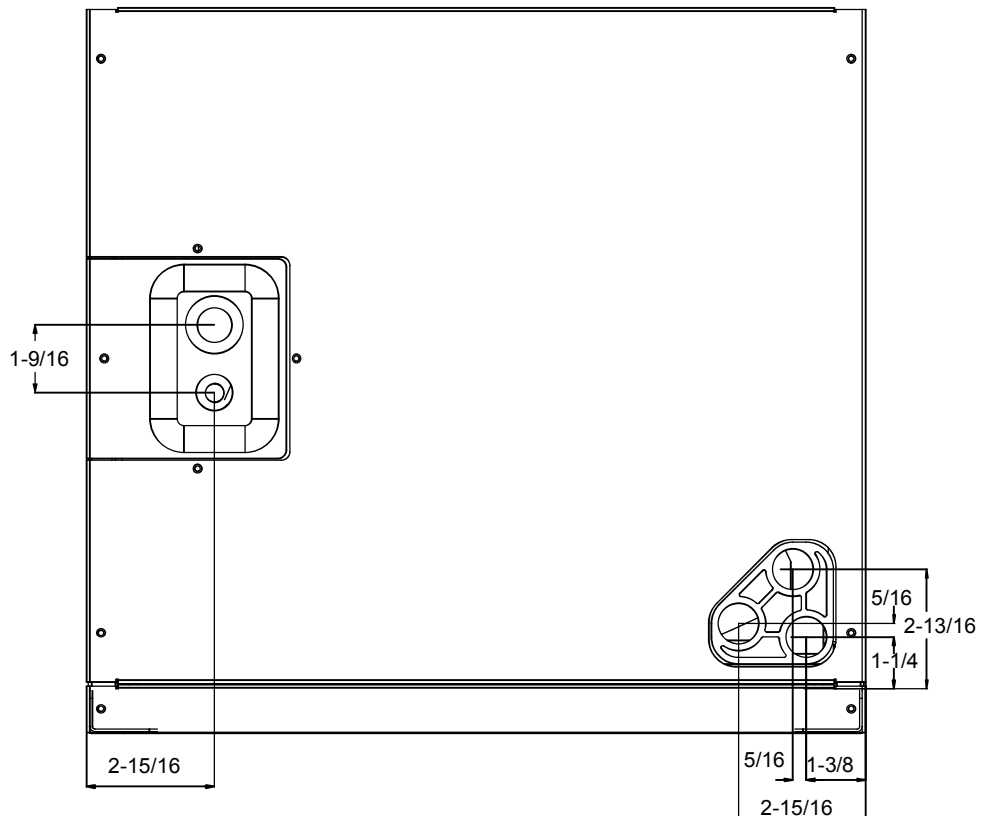

Fig.2 DIMENSIONS FOR FRONT CONNECT COIL

3.2 VERTICAL DOWNFLOW

Conversion to Vertical Downflow: A vertical upflow unit may be converted to vertical downflow. Remove the door and indoor coil and reinstall 180° from original position. See Fig3.

IMPORTANT: To comply with certification agencies and the National Electric Code for downflow application, the circuit breaker(s) on field-installed electric heater kits must be re-installed per procedure below so that the breaker switch "on" position and marking is up and, "off" position and marking is down.

- To rotate breaker(s): Rotate one breaker set (circuit) at a time starting with the one on the right. Loosen both lugs on the load side of the breaker. (Make sure that wires are identified and are reinstalled into proper breaker). Wires are bundles with wire ties, one bundle going to the right lug and one bundle going to the left lug.

- Using a screwdriver or pencil, lift white plastic tab with hole away from breaker until breaker releases from mounting opening.
- With breaker held in hand, rotate breaker so that “on” position is up, “off” position is down with unit in planned vertical mounting position. Insert right wire bundle into top right breaker lug, ensuring all strands of all wires are inserted fully into lug, and no wire insulation is in lug.
- Tighten lug as tight as possible while holding circuit breaker. Check wires and make sure each wire is secure and none are loose. Repeat for left wire bundle in left top circuit breaker lug.
- Replace breaker by inserting breaker mounting tab opposite white pull tab in opening, hook mounting tab over edge in opening.
- With screwdriver or pencil, pull blue tab with hole away from breaker while setting that side of breaker into opening. When breaker is in place, release tab, locking circuit breaker into location in opening.
- Repeat above operation for remaining breaker(s) (if more than one is provided).
- Replace single point wiring jumper bar, if it is used, on line side of breaker and tighten securely.
- Double check wires and lugs to make sure all are secure and tight. Check to make sure unit wiring to circuit breaker load lugs match that shown on the unit wiring diagram.



CAUTION

When using the unit with electrical heater, the switch is used only for electrical heater on the front of panel.

3.3 HORIZONTAL

Horizontal right is the default factory configuration for the units.

Horizontal left isn't the default factory configuration for the units.

Conversion to Horizontal: A vertical upflow unit may be converted to horizontal left by removing indoor coil assembly and reinstalling coil as shown for left hand air supply.

- Rotate unit into the downflow position, with the coil compartment on top and the blower compartment on bottom. See Fig. 3.
- Reinstall the indoor coil 180° from original position. Ensure the retaining channel is fully engaged with the coil rail. See Fig. 3.
- Secondary drain pan kits are recommended when the unit is configured for the horizontal position over a finished ceiling and/or living space.

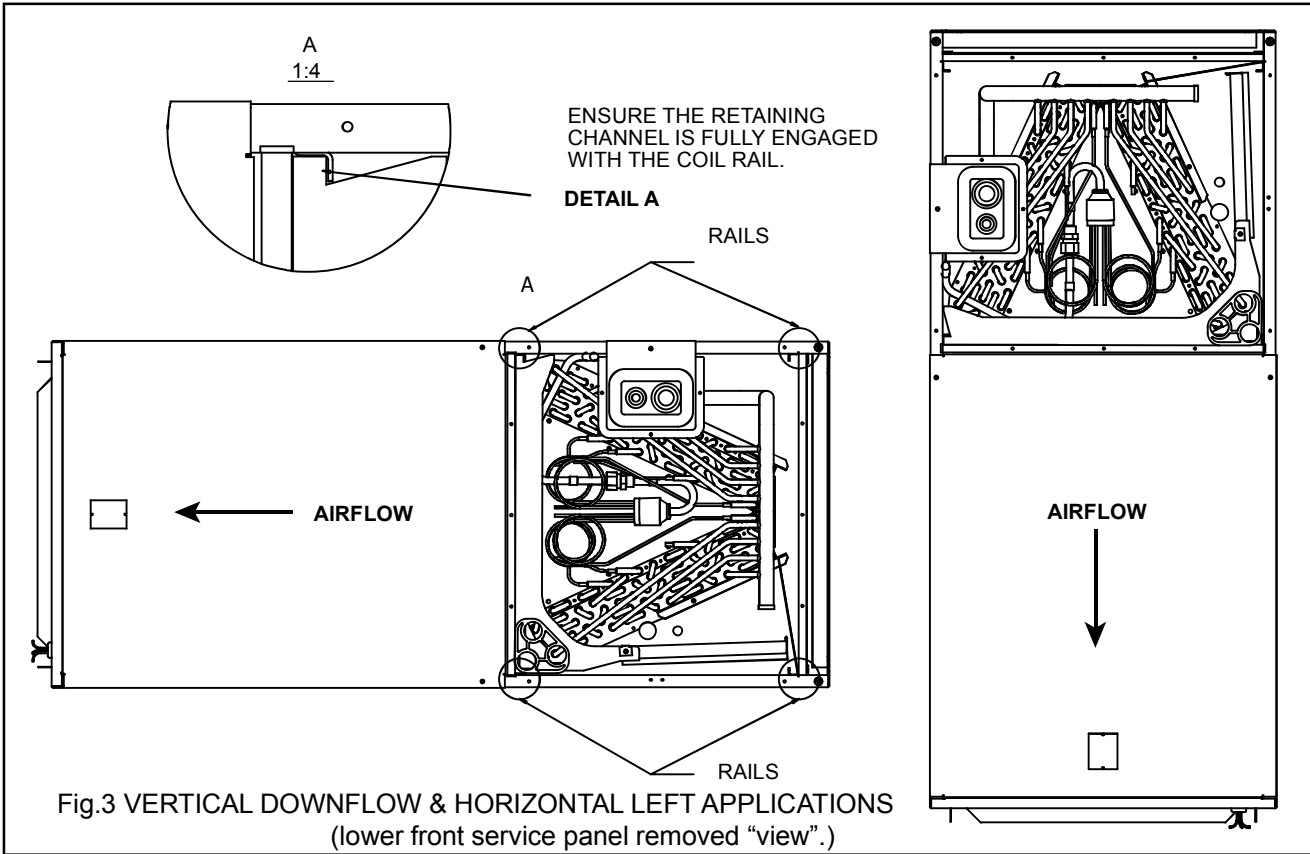
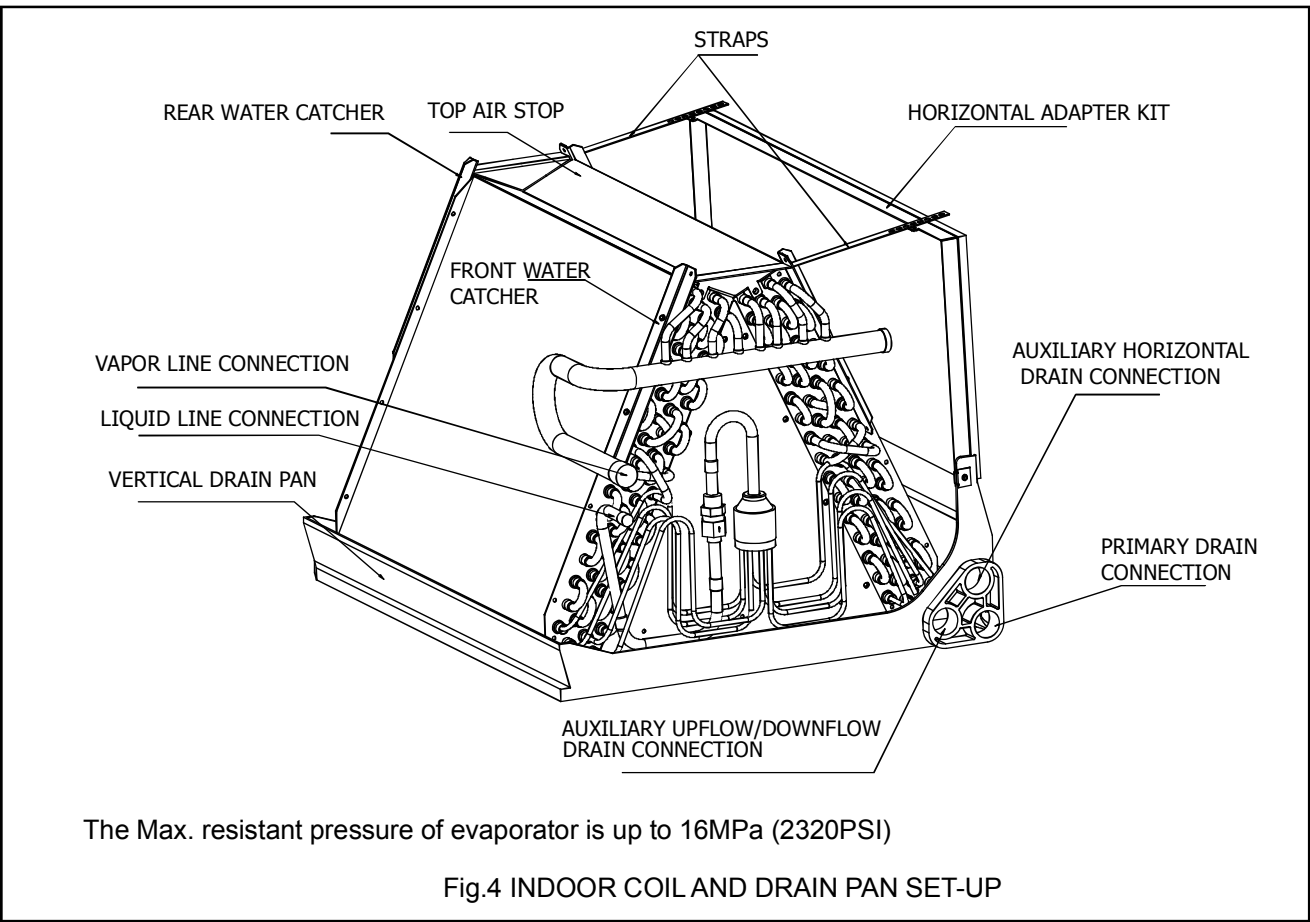

Fig.3 VERTICAL DOWNFLOW & HORIZONTAL LEFT APPLICATIONS
(lower front service panel removed "view".)



The Max. resistant pressure of evaporator is up to 16MPa (2320PSI)

Fig.4 INDOOR COIL AND DRAIN PAN SET-UP



CAUTION

Horizontal units must be configured for right hand air supply or left hand air supply. Horizontal drain pan must be located under indoor coil. Failure to use the drain pan can result in property damage.

3.4 INSTALLATION IN AN UNCONDITIONED SPACE

IMPORTANT: There are two pairs of coil rails in the air handler for default and counter flow application. If the air handler is installed in an unconditioned space, the two unused coil rails should be removed to minimize air handler surface sweating. The coil rails can be easily removed by taking off the 6 mounting screws from both sides of the cabinet.

4.0 ELECTRICAL WIRING

Field wiring must comply with the National Electric Code (C.E.C. in Canada) and any applicable local ordinance.



WARNING

Disconnect all power to unit before installing or servicing. More than one disconnect switch may be required to de-energize the equipment. Hazardous voltage can cause severe personal injury or death.

4.1 POWER WIRING

It is important that proper electrical power is available for connection to the unit model being installed. See the unit nameplate, wiring diagram and electrical data in the installation instructions.

- If required, install a branch circuit disconnect of adequate size, located within sight of, and readily accessible to the unit.
- **IMPORTANT:** After the Electric Heater is installed, units may be equipped with one or two 30-60 amp. circuit breakers. These breaker(s) protect the internal wiring in the event of a short circuit and serve as a disconnect. Circuit breakers installed within the unit do not provide over-current protection of the supply wiring and therefore may be sized larger than the branch circuit protection.
- Supply circuit power wiring must be 75°C minimum copper conductors only. See Electrical Data In this section for ampacity, wire size and circuit protector requirement. Supply circuit protective devices may be either fuses or “HACR” type circuit breakers.
- Power wiring may be connected to either the right, left side or top. Three 7/8”, 1-3/8”, 1-3/4” dia. concentric knockouts are provided for connection of power wiring to unit.
- Power wiring is connected to the power terminal block in unit electric cabinet.

4.2 CONTROL WIRING

IMPORTANT: Class 2 low voltage control wiring should not be run in conduit with main power wiring and must be separated from power wiring, unless class 1 wire of proper voltage rating is used.

- Low voltage control wiring should be 18 Awg. color-coded. For lengths longer than 100 ft., 16 Awg. wire should be used.
- Low voltage control connections are made to low voltage pigtails extending from top of air handler (upflow position - see Figure 3). on the right and left side of the unit for side connection.
- See wiring diagrams attached to indoor and outdoor sections to be connected.
- Make sure, after installation, separation of control wiring and power wiring has been maintained.

4.3 GROUNDING



WARNING

The unit must be permanently grounded. Failure to do so can result in electrical shock causing personal injury or death.

- Grounding may be accomplished by grounding metal conduit when installed in accordance with electrical codes to the unit cabinet.
- Grounding may also be accomplished by attaching ground wire(s) to ground lug(s) provided in the unit wiring compartment.
- Use of multiple supply circuits require grounding of each circuit to lug(s) provided in unit.

4.4 ELECTRICAL DATA

MODEL	VOLTAGE	HERTZ	HP	SPEEDS	CIRCUIT AMPS	MAXIMUM CIRCUIT PROTECTOR
18/ 24 /30	208/230	60	1/2	3	3.0	15(A)
36/42	208/230	60	3/4	3	4.2	15(A)
48/60	208/230	60	1	3	5.5	15(A)

"EHK" ELECTRIC KIT MCA/MOP DATA

Heat Kit Model	(kW)Electric Heat	MIN. Circuit Ampacity		MAX.Fuse or Breaker (HACR) Ampacity	
		240	208	240	208
EHK05A	5	27	23	30	25
EHK08A	7.5	40	34	45	35
EHK10A	10	53	46	60	50
EHK15B	15	79	68	80	70
EHK20B	20	105	91	110	100

"EHK" ELECTRIC KIT & AHU MATCHED TABLE

Heat Kit Model	(kW)Electric Heat	Model 18 / 24 / 30		Model 36/42	Model 48/60
		1.5 Ton	2-2.5 Ton		
EHK05A	5	●	●	●	●
EHK08A	7.5	●	●	●	●
EHK10A	10	×	●	●	●
EHK15B	15	×	×	●	●
EHK20B	20	×	×	●	●

* Heat kit suitable for AHU 4-way position installation[● means available, X means not available].

5.0 AIRFLOW PERFORMANCE

Assumes dry coil with no filter in place.

AIRFLOW DATA

Model Number	Nominal Cooling	Motor Speed	External Static Pressure-Inches W.C.[kPa]								
			CFM	0.1[.02]	0.2[.05]	0.3[.07]	0.4[.10]	0.5[.12]	0.6[.15]	0.7[.17]	0.8[.20]
				Watts	Watts	Watts	Watts	Watts	Watts	Watts	Watts
18 24 30	1.5 Ton TYPE 123 1 ABC	ADJ ON 0 12 1 DE	580	52	68	80	97	111	128	145	163
		ADJ ON 0 12 1 DE or ADJ ON 0 12 1 DE	650	61	76	91	110	125	142	159	182
		ADJ ON 0 12 1 DE	720	76	93	107	126	148	162	182	199

AIRFLOW DATA

Model Number	Nominal Cooling	Motor Speed	External Static Pressure-Inches W.C.[kPa]								
			CFM	0.1[.02]	0.2[.05]	0.3[.07]	0.4[.10]	0.5[.12]	0.6[.15]	0.7[.17]	0.8[.20]
				Watts	Watts	Watts	Watts	Watts	Watts	Watts	Watts
18 24 30	2 Ton TYPE ON 0 1 2 3 1 ABC	ADJ ON 0 1 2 1 DE	750	86	100	120	139	155	174	196	214
		ADJ ADJ ON ON 0 1 2 1 1 2 1 DE DE	830	102	123	140	163	183	203	224	247
		ADJ ON 0 1 2 1 DE	910	123	149	168	185	210	236	262	286
18 24 30	* 2.5 Ton TYPE ON 0 1 2 3 1 ABC	ADJ ON 0 1 2 1 DE	900	123	154	165	188	209	234	254	285
		* ADJ ADJ ON ON 0 1 2 1 1 2 1 DE DE	1000	162	196	206	230	261	284	311	337
		ADJ ON 0 1 2 1 DE	1100	217	254	270	290	317	353	386	410
36/42	3 Ton TYPE ON 0 1 2 3 1 ABC	ADJ ON 0 1 2 1 DE	1080	132	165	177	197	225	246	279	310
		ADJ ADJ ON ON 0 1 2 1 1 2 1 DE DE	1200	171	210	223	248	274	306	329	360
		ADJ ON 0 1 2 1 DE	1320	211	247	269	298	323	355	389	419
	* 3.5 Ton TYPE ON 0 1 2 3 1 ABC	ADJ ON 0 1 2 1 DE	1260	190	228	244	268	294	326	356	390
		* ADJ ADJ ON ON 0 1 2 1 1 2 1 DE DE	1400	241	287	304	334	366	395	425	465
		ADJ ON 0 1 2 1 DE	1540	309	359	382	420	452	488	536	577

AIRFLOW DATA

Model Number	Nominal Cooling	Motor Speed	External Static Pressure-Inches W.C.[kPa]								
			CFM	0.1[.02]	0.2[.05]	0.3[.07]	0.4[.10]	0.5[.12]	0.6[.15]	0.7[.17]	0.8[.20]
				Watts	Watts	Watts	Watts	Watts	Watts	Watts	Watts
48/60	4 Ton		1510	241	272	299	338	360	394	429	460
			1680	310	343	374	418	452	489	521	554
			1850	385	420	469	514	556	594	635	669
	5 Ton		1680	296	337	381	418	450	481	517	553
			1860	389	438	475	523	561	605	655	691
			2040	508	555	600	664	703	743	800	845
			1860	389	438	475	523	561	605	655	691

* FACTORY SETTING

SCFM correction for wet coil = 4% (208V / 230V) .

The air distribution system has the greatest effect on airflow. The duct system is totally controlled by the contractor. For this reason, the contractor should use only industry-recognized procedures.

Heat pump systems require a specified airflow. Each ton of cooling requires between 350 and 450 cubic feet of air per minute (CFM), or 400 CFM nominally.

Duct design and construction should be carefully done. System performance can be lowered dramatically through bad planning or workmanship.

Air supply diffusers must be selected and located carefully. They must be sized and positioned to deliver treated air along the perimeter of the space. If they are too small for their intended airflow, they become noisy. If they are not located properly, they cause drafts. Return air grilles must be properly sized to carry air back to the blower. If they are too small, they also cause noise.

The installers should balance the air distribution system to ensure proper quiet airflow to all rooms in the home. This ensures a comfortable living space.

An air velocity meter or airflow hood can give a reading of system CFM.

6.0 DUCTWORK

Field ductwork must comply with the National Fire Protection Association NFPA 90A, NFPA 90B and any applicable local ordinance.



WARNING

Do not, under any circumstances, connect return ductwork to any other heat producing device such as fireplace insert, stove, etc. Unauthorized use of such devices may result in fire, carbon monoxide poisoning, explosion, personal injury or property damage.

Sheet metal ductwork run in unconditioned spaces must be insulated and covered with a vapor barrier. Fibrous ductwork may be used if constructed and installed in accordance with SMACNA Construction Standard on Fibrous Glass Ducts. Ductwork must comply with National Fire Protection Association as tested by U/L Standard 181 for Class I Air Ducts. Check local codes for requirements on ductwork and insulation.

- Duct system must be designed within the range of external static pressure the unit is designed to operate against. It is important that the system airflow be adequate. Make sure supply and return ductwork, grills, special filters, accessories, etc. are accounted for in total resistance. See airflow performance tables in this manual.
- Design the duct system in accordance with "ACCA" Manual "D" Design for Residential Winter and Summer Air Conditioning and Equipment Selection. Latest editions are available from: "ACCA" Air Conditioning Contractors of America, 1513 16th Street, N.W., Washington, D.C. 20036. If duct system incorporates flexible air duct, be sure pressure drop information (straight length plus all turns) shown in "ACCA" Manual "D" is accounted for in system.
- Supply plenum is attached to the 3/4" duct flanges supplied with the unit. Attach flanges around the blower outlet.

IMPORTANT: If an elbow is included in the plenum close to the unit, it must not be smaller than the dimensions of the supply duct flange on the unit.

- **IMPORTANT:** The front flange on the return duct if connected to the blower casing must not be screwed into the area where the power wiring is located. Drills or sharp screw points can damage insulation on wires located inside unit.
- Secure the supply and return ductwork to the unit flanges, using proper fasteners for the type of duct used and tape the duct-to-unit joint as required to prevent air leaks.

7.0 REFRIGERANT CONNECTIONS

Keep the coil connections sealed until refrigerant connections are made. See the Installation Instructions for the outdoor unit for details on line sizing, tubing installation, and charging information.

Coil is shipped with "N2". Evacuate the system before charging with refrigerant.

Install refrigerant tubing so that it does not block service access to the front of the unit.

Nitrogen should flow through the refrigerant lines while brazing.

Use a brazing shield to protect the cabinet's paint and a wet rag to protect the rubber grommet from being damaged by torch flames. After the refrigerant connections are made, seal the gap around the connections with pressure sensitive gasket.

7.1 CONDENSATE DRAIN TUBING

Consult local codes for specific requirements.

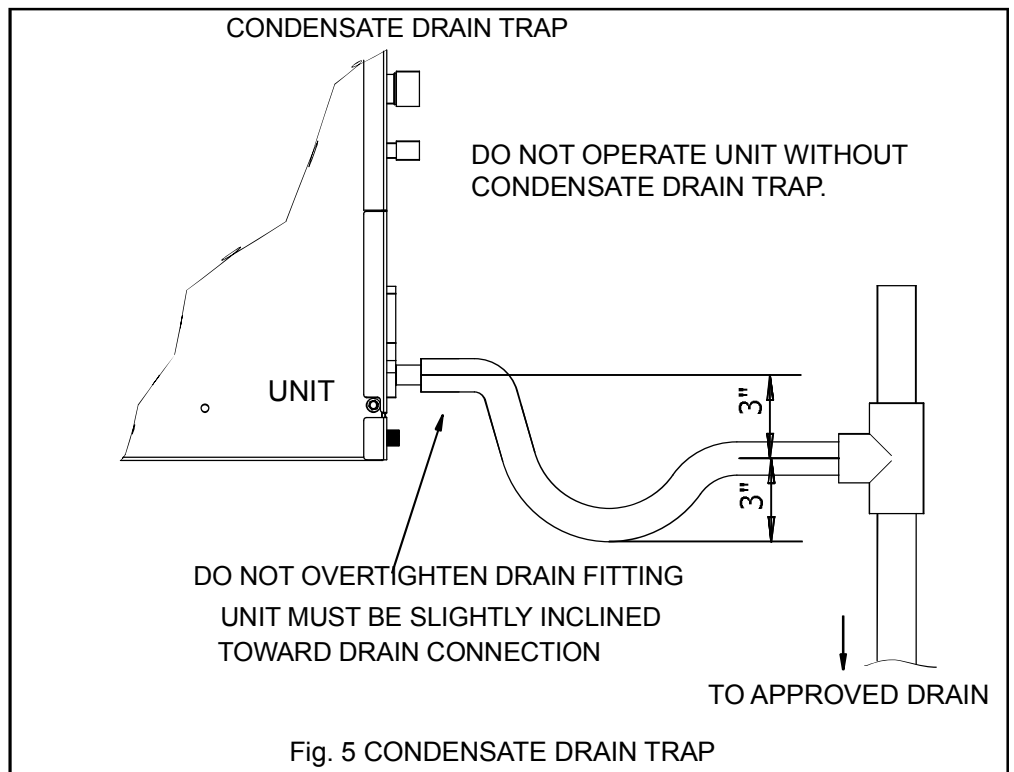

IMPORTANT:

1. When making drain fitting connections to the drain pan, use a thin layer of Teflon paste, silicone or Teflon tape and install, hand tighten.
2. When making drain fitting connections to drain pan, do not overtighten. Overtightening fittings can split pipe connections on the drain pan.

- Install drain lines so they do not block service access to front of the unit. Minimum clearance of 24 inches is required for filter, coil or blower removal and service access.
- Make sure unit is level or pitched slightly toward primary drain connection so that water will drain completely from the pan. (See Fig. 5)
- Do not reduce drain line size less than connection size provided on condensate drain pan.
- All drain lines must be pitched downward away from the unit a minimum of 1/8" per foot of line to ensure proper drainage.
- Do not connect condensate drain line to a closed or open sewer pipe. Run condensate to an open drain or run line to a safe outdoor area.
- The drain line should be insulated where necessary to prevent sweating and damage due to condensate forming on the outside surface of the line.
- Make provisions for disconnecting and cleaning of the primary drain line should it become necessary. Install a 3 inch trap in the primary drain line as close to the unit as possible. Make sure that the top of the trap is below connection to the drain pan to allow complete drainage of pan (See Fig. 5).
- Auxiliary drain line should be run to a place where it will be noticeable if it becomes operational. Homeowner should be warned that a problem exists if water should begin running from the auxiliary drain line.
- Plug the unused drain connection with the plugs provided in the parts bag, using a thin layer of teflon paste, silicone or teflon tape to form a water tight seal.
- Test condensate drain pan and drain line after installation is complete. Pour water into drain pan, enough to fill drain trap and line. Check to make sure drain pan is draining completely, no leaks are found in drain line fittings, and water is draining from the termination of the primary drain line.

8.0 AIR FILTER (not factory-installed)

- External filter or other means of filtration is required. Units should be sized for a maximum of 300 feet/min. air velocity or what is recommended for the type filter installed.

Filter application and placement are critical to airflow, which may affect the heating and cooling system performance. Reduced airflow can shorten the life of the system's major components, such as motor, limits, elements, heat relays, evaporator coil or compressor. Consequently, we recommend that the return air duct system have only one filter location. For systems with a return air filter grill or multiple filter grills, can have a filter installed at each of the return air openings.

If adding high efficiency filters or electronic air filtration systems, it is very important that the air flow is not reduced. If air flow is reduced the overall performance and efficiency of the unit will be reduced. It is strongly recommended that a professional installation technician is contacted to ensure installation of these such filtration systems are installed correctly.

IMPORTANT: DO NOT DOUBLE FILTER THE RETURN AIR DUCT SYSTEM. DO NOT FILTER THE SUPPLY AIR DUCT SYSTEM. THIS WILL CHANGE THE PERFORMANCE OF THE UNIT AND REDUCE AIRFLOW .



WARNING

Do not operate the system without filters. A portion of the dust entrained in the air may temporarily lodge in the duct runs and at the supply registers. Any circulated dust particles could be heated and charred by contact with the air handler elements. This residue could soil ceilings, walls, drapes, carpets and other articles in the house. Soot damage may occur with filters in place, when certain types of candles, oil lamps or standing pilots are burned.

9.0 FILTER INSTALLATION DIMENSIONS

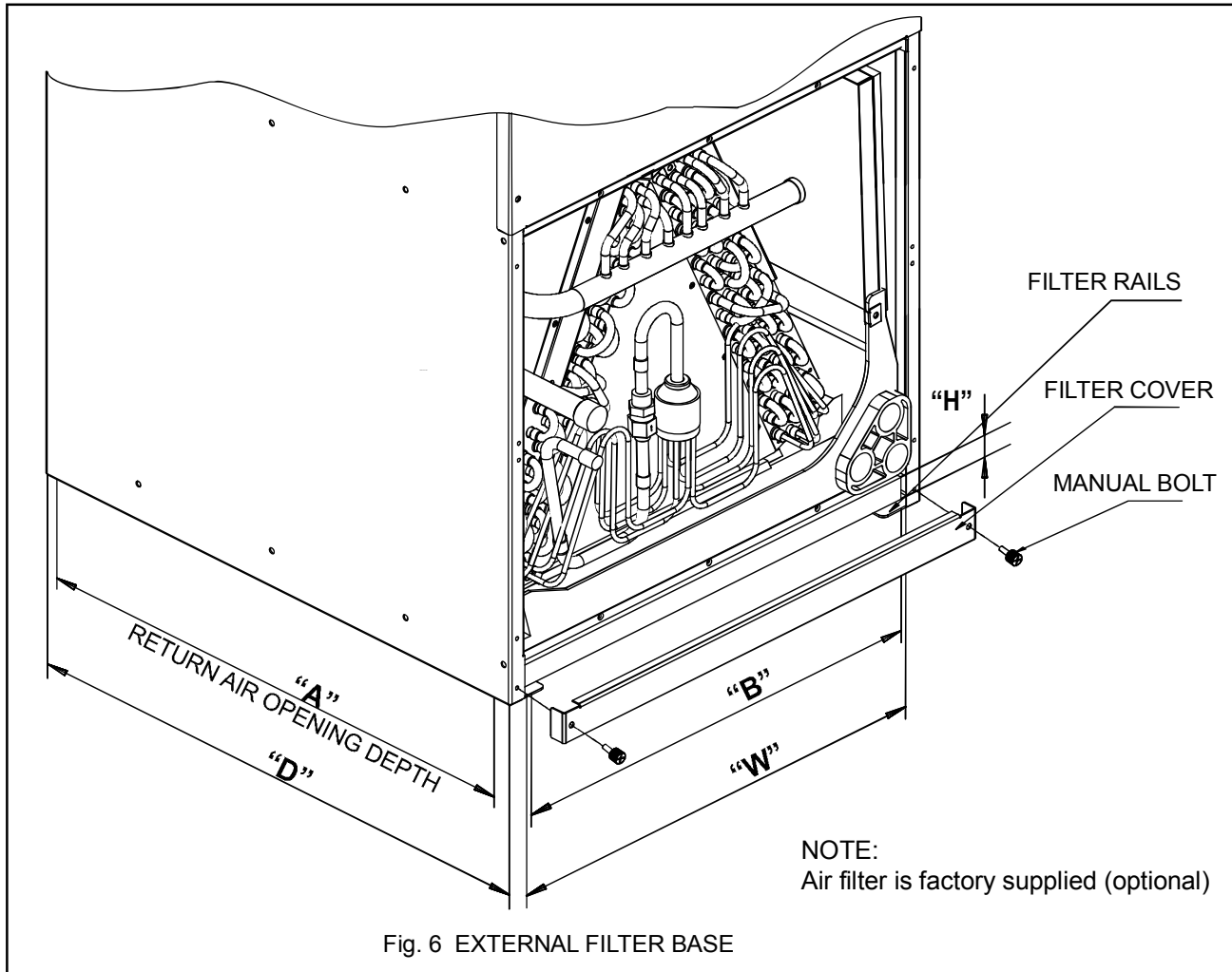

DIMENSIONAL DATA

MODEL	FILTER SIZE IN [mm]	"W" IN [mm]	"D" IN [mm]	"H" IN [mm]	Return width "A" IN	Return length "B" IN
18 /24 /30	18X20[457X508]	18.3[466]	21.6[548]	1[25.4]	20.8	16.3
36/42	20X22[508X559]	20.7[526]	23.9[608]	1[25.4]	23	18.8
48/60	20X22[508X559]	20.7[526]	23.9[608]	1[25.4]	23	18.8

• AIR FILTER REMOVAL

1. Remove bolts manually, remove air filter recover, see in Fig 6;
2. Hold the edge of the air filter and extract out .
3. Clean the air filter (Vacuum cleaner or pure water may be used to clean the air filter. If the dust accumulation is too heavy, use soft brush and mild detergent to clean it and dry out in cool place) .

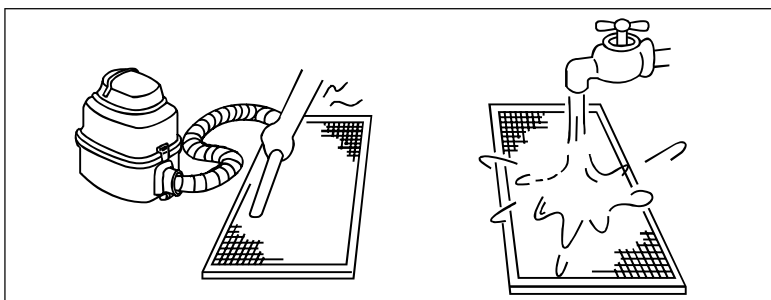

10.0 WIRING DIAGRAM

1. To avoid the electrical shock, please connect the air conditioner with the ground lug.
2. Don't pull the power wiring hard.
3. When connecting the air conditioner with the ground, observe the local codes.
4. If necessary, use the power fuse or the circuit, breaker or the corresponding scale ampere.

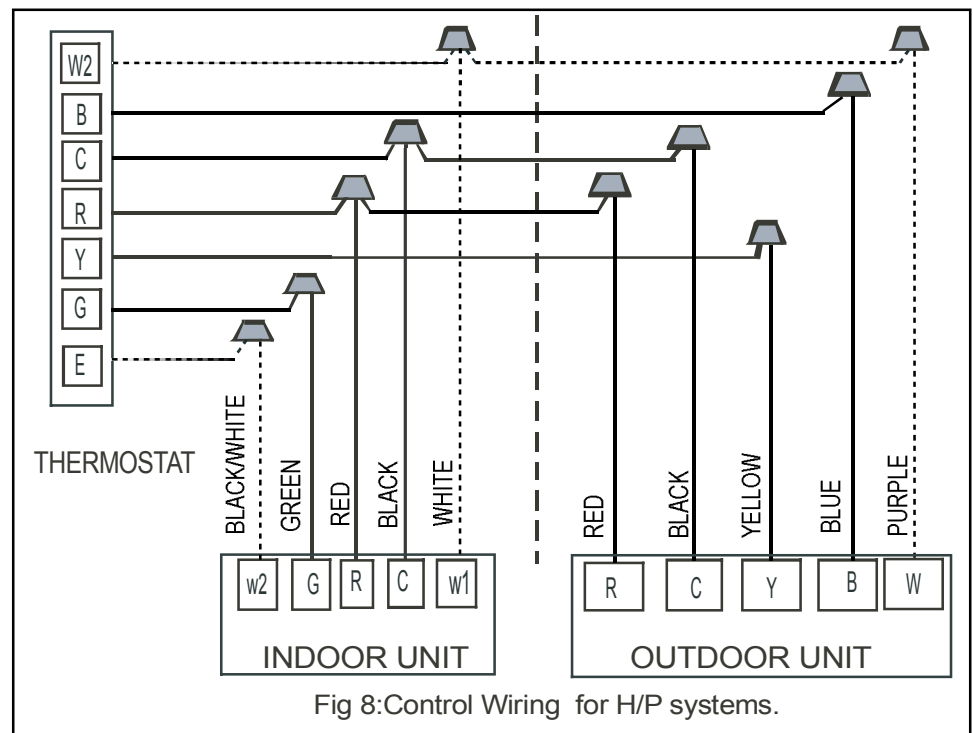
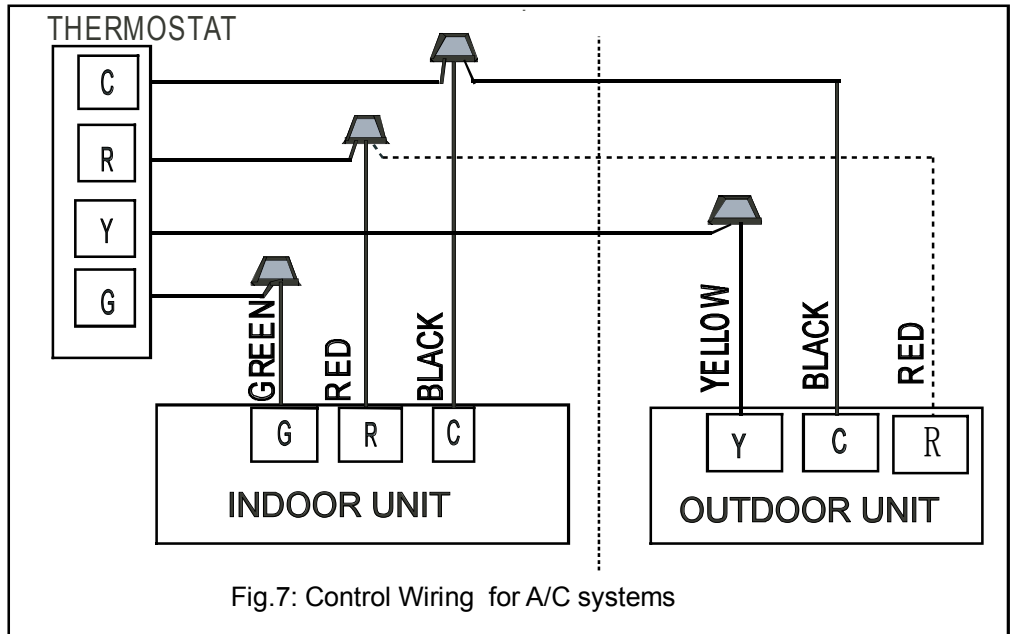

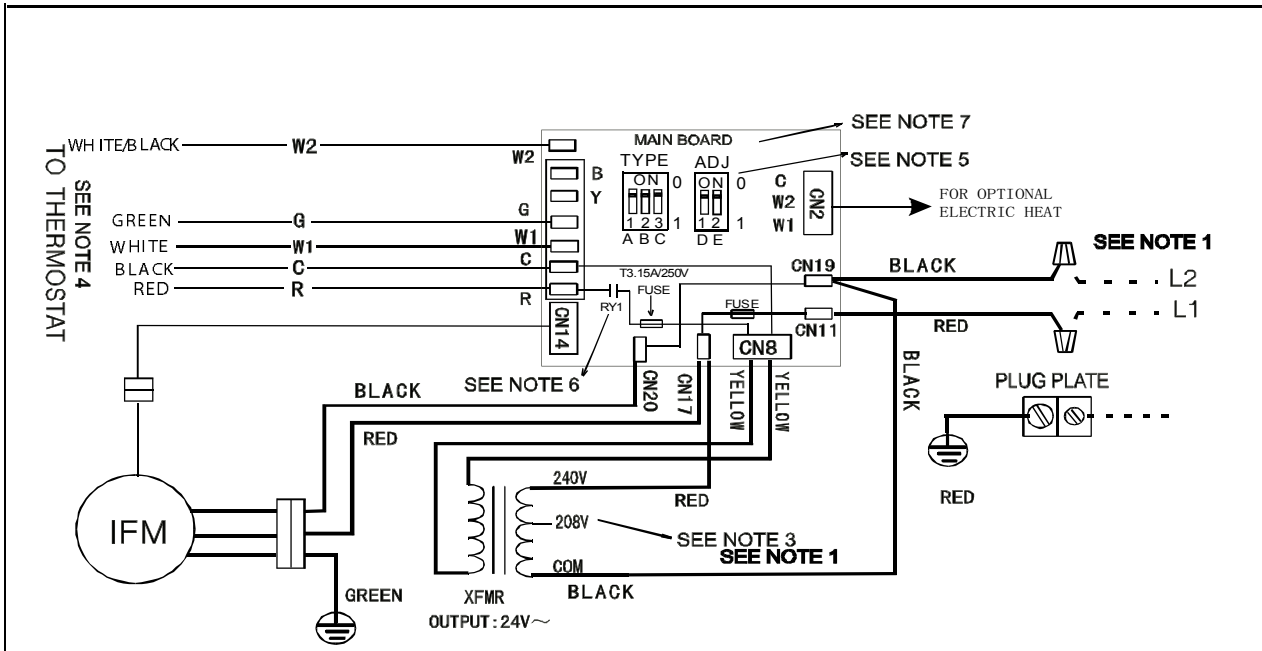

NOTES:

- 1: For the Air handler without installing Electric Heat; connect the supply power to "L1" and "L2" wire .
- 2: For the Air handler with Electric Heat, connect the supply power to circuit breaker. If you order the Heat Kit without circuit breaker, connect the power supply to the terminal block provided on the heater.
- 3: Remove the red lead from "240V" terminal and then connect the red lead to "208V" terminal on the transformer for 208 volts.
- 4: "W2" wire is not provided in some models, and tap and seal the unused wire.
- 5: switch "TYPE" and "ADJ" choose different model and air volume . please refer to the user manual to choose "0" or "1"
- 6: "RY1" will disconnect when the fan motor malfunction.
- 7: "MAIN BOARD" has a 90s off delay when "G" is de-energized.

NOTE 5

TYPE	Nominal Cooling
A B C	
0 0 0	5 Ton
0 0 1	1.5 Ton
0 1 0	2 Ton
0 1 1	2.5 Ton
1 0 0	3 Ton
1 0 1	3.5 Ton
1 1 0	4 Ton
1 1 1	5 Ton

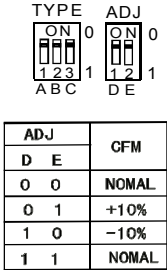

- STEADY ON = NORMAL
- OFF = MAIN BOARD FAILURE
- 5FLASH = IFM FAILURE

XFMR TRANSFORMER
 RY1 RELAY
 RY2 RELAY
 IFM INDOOR FAN MOTOR

DISCONNECT ALL POWER BEFORE SERVING. USE COPPER CONDUCTORS ONLY WARNING CABINET MUST BE PERMANENTLY GROUNDED AND ALL WIRING: TO CONFORM TO I.E.C, N.E.C, C.E.C, C.L.C, AND LOCAL CODES AS APPLICABLE REPLACEMENT WIRE MUST BE THE SAME GAUGE AND INSULATION TYPE AS ORIGINAL WIRE.

————— 1015 600V 105°C
 ————— 1015 600V 105°C 24V~
 FIELD WIRING PER LOCAL CODE

NOTE

Cut off the power supply when appear "IFM FAILURE".Swich on power supply again after 20 seconds if power and wiring is correct .

Fig.9:Indoor Unit Wiring Diagram for A/C systems and H/P systems

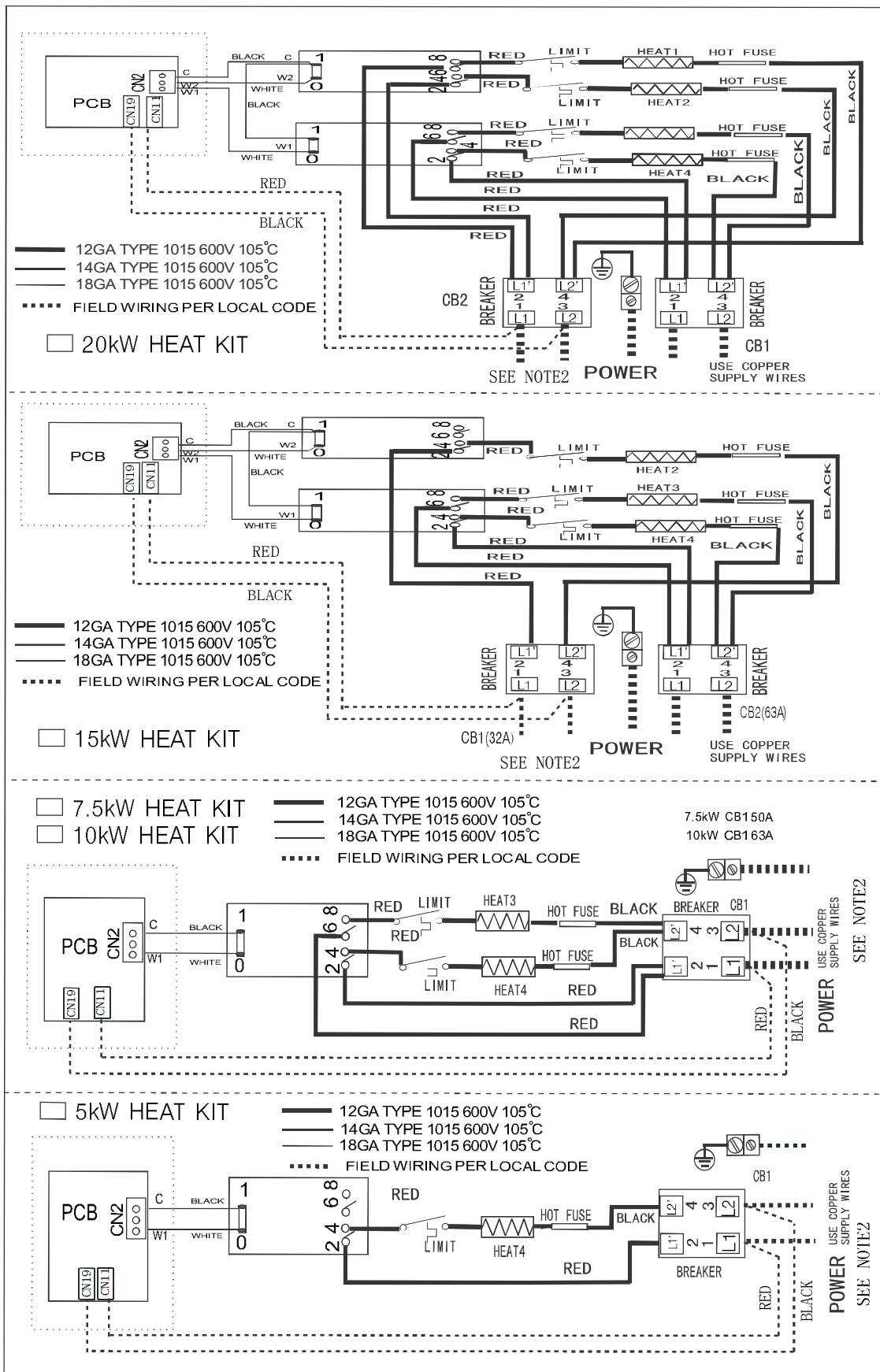

Fig.10:Indoor Unit Wiring Diagram for Electric Heat

