

# The Aspen<sup>®</sup> Woodburning Stove Model 1920

## Homeowner's Installation and Operating Manual

For use in the  
United States and Canada

**SAFETY NOTICE: IF THIS APPLIANCE IS NOT PROPERLY INSTALLED, OPERATED AND MAINTAINED, A HOUSE FIRE MAY RESULT. TO REDUCE THE RISK OF FIRE, FOLLOW THE INSTALLATION INSTRUCTIONS. FAILURE TO FOLLOW INSTRUCTIONS MAY RESULT IN PROPERTY DAMAGE, BODILY INJURY OR EVEN DEATH. CONTACT LOCAL BUILDING OFFICIALS ABOUT RESTRICTIONS AND INSTALLATION INSPECTION REQUIREMENTS IN YOUR AREA.**

**NATIONAL  
FIREPLACE  
INSTITUTE**



**CERTIFIED**

[www.nficertified.org](http://www.nficertified.org)

We recommend that our woodburning hearth products be installed and serviced by professionals who are certified in the U.S. by the National Fireplace Institute<sup>®</sup> (NFI) as NFI Woodburning Specialists or who are certified in Canada by Wood Energy Technical Training (WETT).



**Do Not Discard This Manual: Retain for Future Use**

## Introduction

Thank you for choosing a Vermont Castings Aspen to meet your heating needs. We're confident you will find the Aspen to be an effective wood-burning heater incorporating modern, non-catalytic combustion technology with the classic aesthetic appeal of its Vermont Castings lineage.

The Aspen achieves high-efficiency through precisely calibrated delivery of primary and secondary air into a refractory-insulated firebox. Properly operated and maintained according to the guidelines in this manual, your Aspen will provide safe, dependable, and economical heating for years to come.

The Aspen Model 1920 is listed by OMNI-Test Laboratories of Portland, Oregon. The test standards are ANSI/UL-1482 for the United States and ULC S627 for Canada.

The Aspen Model 1920 is listed for burning wood fuel only. Do not burn other fuels.

The Aspen Model 1920 is approved for installation in manufactured (mobile) homes in the United States only using the optional Mobile Home Kit #1898 in accordance with the instructions in that kit and any local codes.

The Aspen Model 1920 complies with the standards set forth by the Federal Environmental Protection Agency, 40 CFR Part 60.532(b)(2), as stated on the permanent label attached to each stove.

We recommend that you hire a professional, solid-fuel stove technician to install your Aspen, or to advise you on the installation should you attempt to install it yourself. Consult the authority having local jurisdiction (such as a municipal building department, fire department, fire prevention bureau, etc.) before installation to determine the need for a building permit. Also, consult your insurance agent to be sure your installation complies with specific requirements that may vary locally.

In addition to directions on installation and operation, this manual includes directions on maintenance and assembly. Please read this entire manual before you install or operate your new room heater.

**Save These Instructions For Future Reference.**

### Table of Contents

Specifications .....	3
Installation Requirements .....	4
Clearances .....	12
Assembly .....	15
Operation.....	17
Maintenance .....	21
Appendix - Draft Management.....	24
Replacement Parts .....	27
Warranty .....	31

**Proposition 65 WARNING:** Fuels used in gas, woodburning or oil fired appliances, and the products of combustion of such fuels, contain chemicals known to the State of California to cause cancer, birth defects and other reproductive harm. California Health & Safety Code Sec. 25249.6

# Specifications

## Aspen, Model 1920

EPA Emissions rating ..... 4.3 (g/h, non-catalytic)\*  
 Maximum heat output ..... 18,000 Btu's/hr.<sup>1</sup>  
 Area heated ..... Up to 600 sq. ft. (56 sq. m)<sup>2</sup>  
 Fuel size/type ..... 16" (41 cm) logs  
 Loading ..... Front  
 Chimney connector ..... 6" (152 mm) diameter  
 Chimney flue size ..... 6" (152 mm) minimum  
 Flue exit position ..... Reversible, top or rear  
 Primary air ... Manually set, thermostatically maintained  
 Ash handling system ..... Removable ash pan  
 Glass panel ..... High-temperature ceramic  
 Weight ..... 240 lbs. (110 kg)  
 Width (Left leg - Right leg) ..... 16" (406 mm)  
 Depth (Front leg - Rear leg) ..... 23" (584 mm)  
 Height to top of top exit flue collar ..... 24" (610 mm)  
 Height to top of rear exit flue collar ..... 21" (533 mm)

<sup>1</sup> This value can vary depending on how the stove is operated, the type and moisture content of the fuel used, as well as the design, construction and climatic location of your home. Figures shown are based on maximum fuel consumption obtained under laboratory conditions and on average efficiencies.

<sup>2</sup> These values are based on operation in building code-conforming homes under typical winter climate conditions in New England. If your home is of nonstandard construction (e.g., unusually well insulated, not insulated, built under ground, etc.) or if you live in a more severe or more temperate climate, these figures may not apply. Since so many variables affect performance, consult your Vermont Castings authorized dealer to determine realistic expectations for your home.

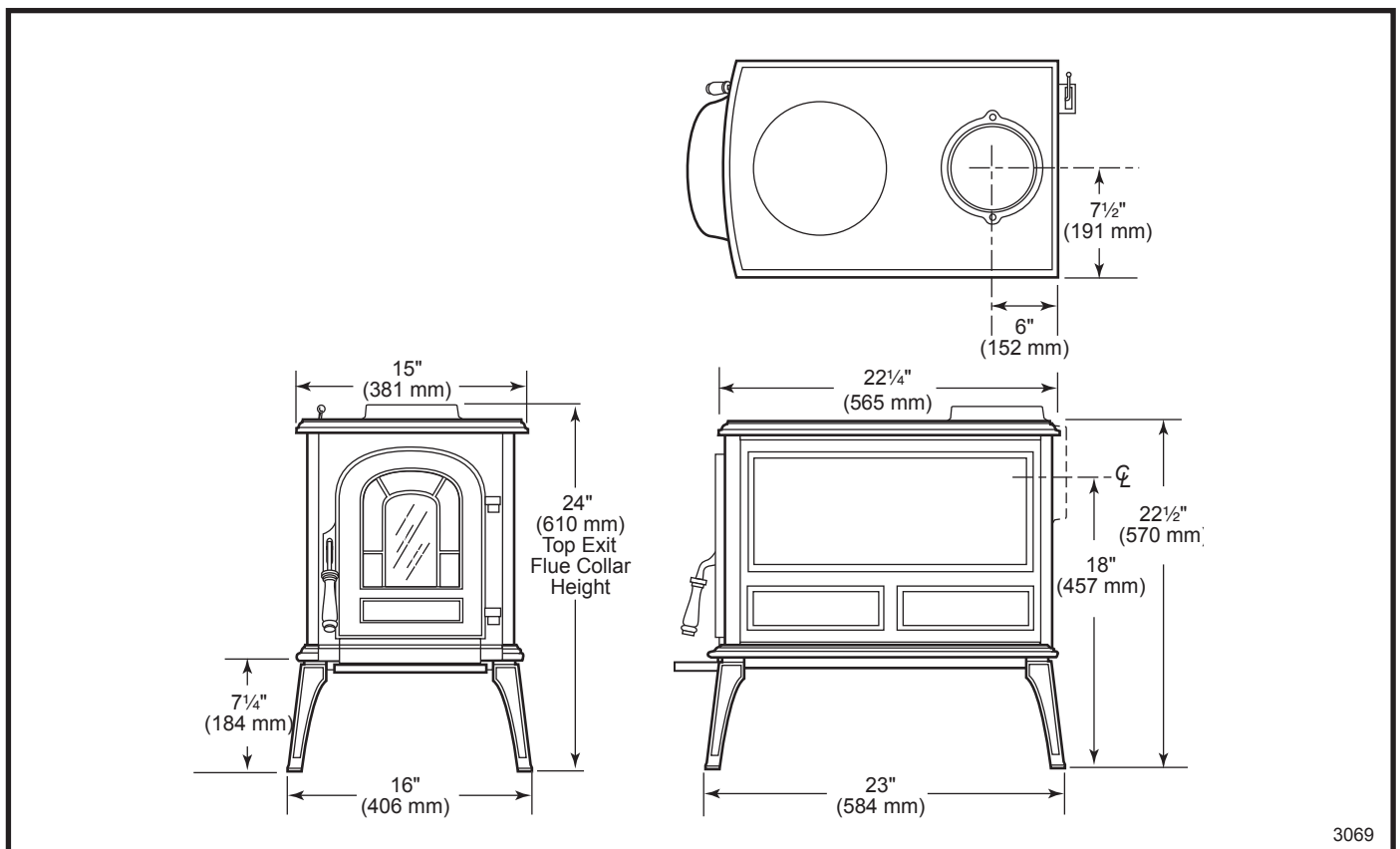

Fig. 1 Aspen 1920 specifications.

## Installation

**SAFETY NOTICE: IF YOUR STOVE IS NOT PROPERLY INSTALLED, OPERATED AND MAINTAINED, A HOUSE FIRE MAY RESULT. FOR SAFETY, FOLLOW ALL INSTALLATION, OPERATION AND MAINTENANCE DIRECTIONS. CONTACT LOCAL BUILDING OFFICIALS ABOUT RESTRICTIONS AND INSTALLATION INSPECTION REQUIREMENTS IN YOUR AREA.**

Before you begin an installation, review your plans to be certain that:

- Your stove and chimney connector will be far enough from combustible material to meet all clearance requirements.
- The floor protector is large enough and is constructed properly to meet all requirements.
- You have all necessary permits from local authorities.

Your local building official is the final authority for approving your installation as safe and determining that it meets local and state codes.

The metal label permanently attached to the back of the stove indicates that the Aspen has been tested to current UL and ULC standards by Intertek Testing Services of Middleton, Wisconsin. Clearance and installation information is also printed on the label. Local authorities generally will accept the label as evidence that, when the stove is installed according to the information on the label and in this manual, the installation meets codes and can be approved. Codes, however, vary in different areas. Before starting the installation, review your plans with the local building authority. Your local dealer can provide any additional information needed.

For any unresolved questions about installation, refer to the National Fire Protection Association's publication ANSI/NFPA 211-1988 Standard for Chimneys, Fireplaces, Vents and Solid Fuel Burning Appliances. In Canada, the equivalent publication is CSA CAN-B365, Installation Code for Solid Fuel Burning Appliances and Equipment. These standards are the bases for many national codes. They are nationally recognized and are accepted by most local authorities. Your local dealer or your local building official may have a copy of these regulations.

**IMPORTANT: Failure to follow these installation instructions may result in a dangerous situation, including a chimney or house fire. Follow all instructions exactly and do not allow makeshift compromises to endanger property and personal safety.**

### Chimneys

Your stove must be connected either to a sound masonry chimney that meets local codes, to a relined masonry chimney that meets local codes, or to an approved prefabricated metal chimney. Whichever of those types you use, the chimney and chimney connector must be in good condition and kept clean.

If you use an existing masonry chimney, it must be inspected to ensure safe condition before the stove is installed. Your local professional chimney sweep, building inspector, or fire department official will be able to make the inspection or direct you to someone who can.

The chimney should extend at least 3' (914 mm) above the highest point where it passes through a roof, and at least 2' (610 mm) higher than any portion of a building within 10' (3 m).

To assure proper draft and good performance, any chimney used with this stove should extend at least 16' (4.9 m) above the flue collar of the stove.

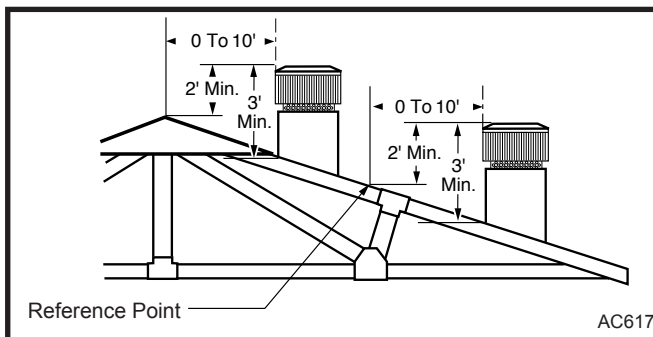

**Fig. 2** The 2'-3'-10' Chimney Rule.

### Masonry Chimneys

An existing masonry chimney must be inspected to confirm that it has a lining. Do not use an unlined chimney. The chimney also should be examined for cracks, loose mortar, other signs of deterioration, and blockage. Repair any defects before the chimney is used with your stove.

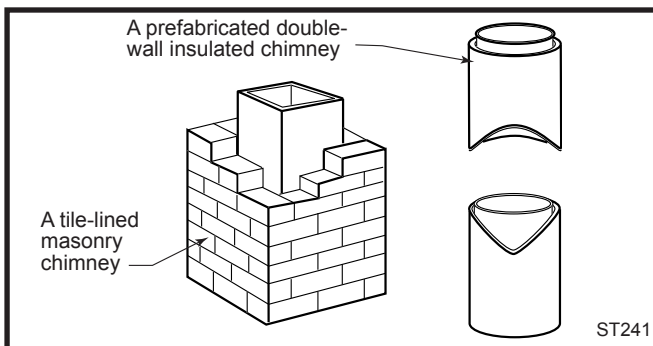

**Fig. 3** Standard Chimney Types

### Masonry Chimneys, cont'd.

- Unused openings in an existing masonry chimney must be sealed with masonry to the thickness of the chimney wall, and the chimney liner should be repaired. Openings sealed with pie plates or wallpaper are a hazard and should be sealed with mortar or refractory cement. In the event of a chimney fire, flames and smoke may be forced out of these unused thimbles.
- The chimney should be thoroughly cleaned before use.
- A newly-built masonry chimney must conform to the standards of local building code, or, in the absence of a local code, to a recognized national code. Masonry chimneys must be lined, either with code-approved masonry or precast refractory tiles, stainless steel pipe, or a code-approved, "poured-in-place" liner. The chimney clean-out door must seal tightly to ensure a good draft.

### Prefabricated Chimneys

A prefabricated metal chimney must be one that is tested and listed for use with solid-fuel burning appliances to the High-Temperature (H.T.) Chimney Standard UL-103-1985 (2100°F.) for the United States, and High Temperature (650°C) Standard ULC S-629 for Canada.

### Chimney Size

This stove is approved for venting into a masonry chimney with a nominal flue size of 8" x 8" (203 x 203 mm), and into a round flue size of 8" (203 mm) or 6" (152 mm).

It may be vented into larger chimneys as well. However, chimneys with liners larger than 8" x 12" (203 x 305 mm) may experience rapid cooling of smoke and reduction in draft, especially if they are located outside the home. Such large chimneys may need to be insulated or have the flue relined for proper stove performance.

**Do not connect this unit to a chimney flue serving another appliance.**

**NOTE: Do not vent this stove into a factory-built (zero-clearance) fireplace. This stove has not been tested and listed for that type of installation. Factory-built fireplaces and their chimneys are specifically designed as a unit for use as fireplaces. It may void the listing or be hazardous to adapt them for any other use.**

**Do not connect the STOVE to any air distribution duct or system.**

Ask your dealer about components available for connecting the stove to a steel chimney liner.

### Chimney Connector Guidelines

A chimney connector is the double-wall or single-wall pipe that connects the stove to the chimney. The chimney itself is a masonry or prefabricated structure that encloses the flue. Chimney connectors are used only to make the connection from the stove to the chimney. They are for interior use only.

Double-wall connectors must be tested and listed for use with solid-fuel burning appliances. Single-wall connectors should be made of 24 gauge or heavier steel, and should be 6" (152mm) in diameter. Do not use galvanized chimney connector; it cannot withstand the high temperatures that can be reached by smoke and exhaust gases, and may release toxic fumes under high heat.

If possible, do not pass the chimney connector through a combustible wall or ceiling. If passage through a combustible wall is unavoidable, refer to the recommendations in the section following on Wall Pass-throughs. Do not pass the connector through an attic, a closet or any similar concealed

space. The whole chimney connector should be exposed and accessible for inspection and cleaning.

Install the single wall chimney connector not less than 18" (457mm) from the ceiling. Keep it as short and direct as possible, with no more than two 90 degree turns. If possible, use 45° elbows. Slope horizontal runs of connectors upward 1/4" per foot (20mm per meter) going from the stove toward the chimney. The recommended maximum length of a horizontal run is 3' (914mm), and the total length of chimney connector should be no longer than 8' (2.5 meters).

In cathedral ceiling installations, extend the prefabricated chimney downward to within 8 feet (2.4m) of the stove.

**SAFETY NOTE: Always wear gloves and protective eyewear when drilling, cutting or joining chimney connector sections .**

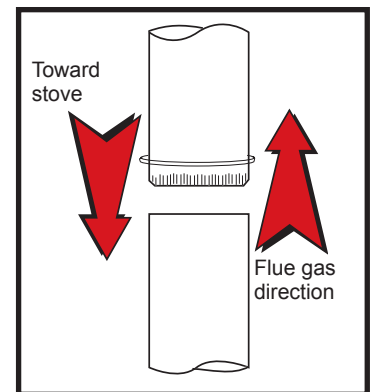

Fig. 4 Chimney connector.



## Double-wall Chimney Connectors

The Aspen is approved for installation in the U.S. and Canada with double-wall chimney connectors that have been tested and listed for use with solid-fuel burning appliances by a recognized testing laboratory.

Follow the instructions for assembling and installing double-wall connectors provided by the manufacturer of the double-wall chimney. To ease assembly and help assure safety, use chimney components manufactured by a single source.

**NOTE: For installations using double-wall connectors, minimum clearances must conform to those listed in the clearance chart on Page 13.**

## Single-wall Chimney Connectors

- Beginning at the flue collar of the stove, assemble the chimney connector. Insert the first crimped end into the stove's flue collar, and keep each crimped end pointing toward the stove. Using the holes in the flue collar as guides, drill 1/8" (3 mm) holes in the bottom of the first section of chimney connector and secure it to the flue collar with three #10 x 1/2" sheet metal screws.
- Secure each joint between sections of chimney connector, including telescoping joints, with at least three sheet metal screws. The predrilled holes in the top of each section of chimney connector serve as guides when you drill 1/8" (3mm) holes in the bottom of the next section.
- Secure the chimney connector to the chimney. Instructions for various installations follow.
- Be sure the installed stove and chimney connector are correct distances from nearby combustible material.

**NOTE:** Special slip pipes and thimble sleeves that form telescoping joints between sections of chimney connector are available to simplify assembly. Slip pipes eliminate the need to cut individual connector sections. Consult your local dealer about these special connector sections.

## Securing the Single-wall Connector to a Prefabricated Chimney

Follow the installation instructions of the chimney manufacturer exactly.

Special adapters are available from your local dealer to make the connection between the prefabricated chimney and the chimney connector. The top of such adapters attach directly to the chimney or to the chimney's ceiling support package. The bottom of the adapter is secured to the chimney connector.

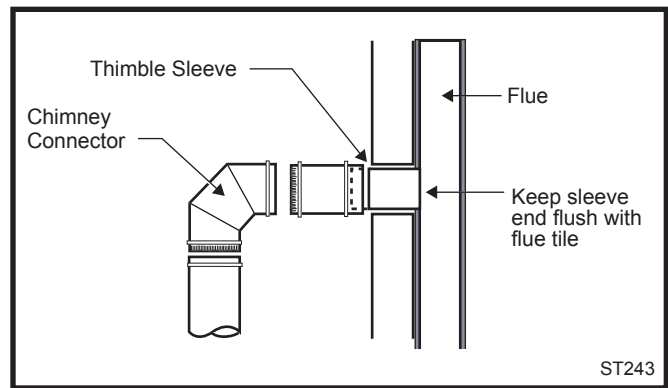

**Fig. 6** The thimble, made of either ceramic or metal, must be cemented securely in place.

The adapter forms a union between the chimney and chimney connector that ensures any soot or creosote falling from the inner walls of the chimney will stay inside the chimney connector.

## Securing the Single-wall Connector to a Masonry Chimney

The Aspen may be connected to either a freestanding masonry chimney or to a fireplace masonry chimney.

### Freestanding Installations

If the chimney connector must pass through a combustible wall to reach the chimney, follow the recommendations for Wall Pass-Through construction on pages 7-8.

The opening through the chimney wall to the flue - the "breach" - must be lined with a ceramic or metal thimble which is securely cemented in place.

A metal pipe section called the "thimble sleeve," slightly smaller in diameter than standard connector and the thimbles, will allow the removal of the chimney connector system for inspection and cleaning. Thimble sleeves are available from your local dealer.

To install a thimble sleeve, slide it into the breach until it is flush with the inner flue wall. Be sure that it does not extend into the flue passage where it could interfere with the draft.

The thimble sleeve should protrude 1-2" (25-50 mm) into the room. Use furnace cement and thin gasketing to seal the sleeve in place in the thimble. Secure the chimney connector to the outer end of the sleeve with sheet metal screws.

## Connection Above the Fireplace

In this installation, the chimney connector enters the fireplace flue through a thimble located above the fireplace. The liner of the fireplace chimney should extend at least to the point at which the chimney connector enters the chimney. Follow all the guidelines for installing a chimney connector into a freestanding masonry chimney, and pay special attention to these additional points:

- Check the stove and chimney connector clearances to combustible mantel and trim materials. If necessary, use a combination of mantel, trim, and connector heat shields to provide the required clearances.
- Double-check connector clearance to the ceiling.
- The fireplace damper must be closed and sealed to prevent room air from being drawn up the flue which could reduce performance. However, it must be possible to reopen the damper to inspect or clean the chimney.

## Connection Through the Fireplace

If your fireplace opening height is at least 21½" (546 mm), you may install a stove through the opening using a "positive connection" kit available from your local dealer. These kits provide a secure connection between the stove flue collar and the chimney flue.

Confirm that the stove location is within the required clearance specifications for the mantel and surrounding fireplace trim. Refer to Page 12.

Floor protection requirements also apply to fireplace installations. Refer to Page 9.

## Wall Pass-throughs

Whenever possible, design the installation so that the connector does not pass through a combustible wall. If you must include a wall pass-through in your installation, check with your building inspector before you begin. Also check with the chimney connector manufacturer for any specific requirements.

Consult with your dealer regarding special connection components available for use as wall pass-throughs. Use only parts that have been tested and listed for use as a wall pass-through.

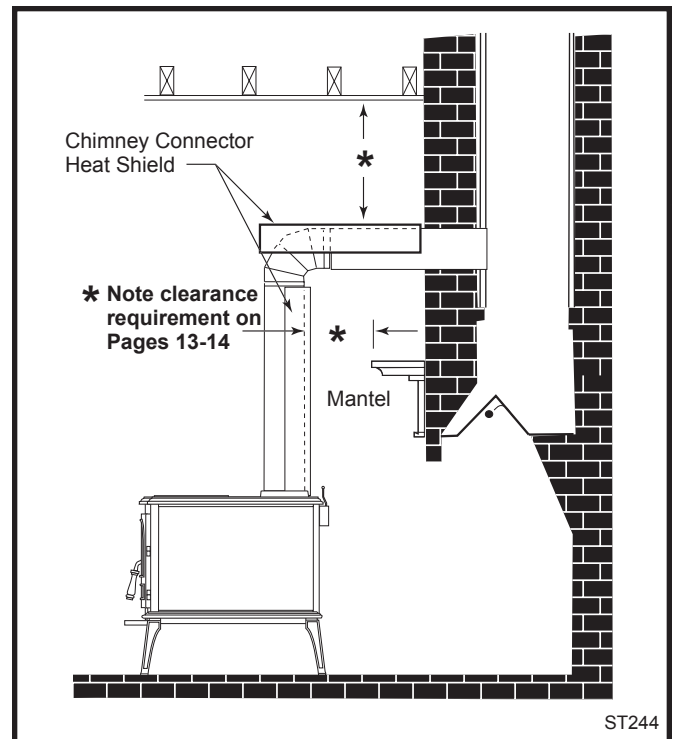

**Fig. 7** If the clearance between the chimney connector and either the ceiling or the mantel is inadequate, a protective heat shield is required.

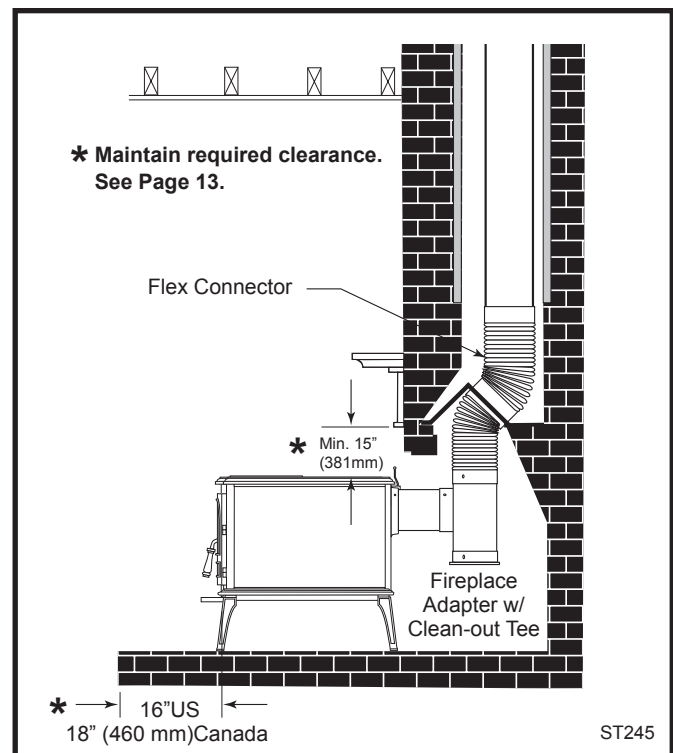

**Fig. 8** Special adapter kits are available from your local dealer to simplify fireplace installations.

## U.S. Requirements:

The National Fire Protection Association (NFPA) has established guidelines for use in the United States for passing chimney connectors through combustible walls. Many building code inspectors follow these guidelines.

Figure 9 shows one NFPA-approved method. All combustible material in the wall is cut away to provide 12" (305 mm) clearance to the connector. Brick and mortar are used to enclose the clearance area.

### Alternate methods approved by the NFPA:

- Using a section of double-wall chimney with a 9" (229 mm) clearance to combustibles. (Fig. 10)
- Placing a chimney connector pipe inside a steel double-wall ventilated thimble, which is then separated from combustibles by 6" (152 mm) of fiberglass insulating material. (Fig. 11)
- Placing a chimney connector pipe inside a section of 9" (229 mm) diameter, solid-insulated, factory-built chimney, with two inches of air space between the chimney section and combustibles. (Fig. 12)

## Canadian Requirements:

In Canada, the Canadian Standards Association has established specific guidelines regarding wall pass-through design. Figure 13 shows one approved method in which all combustible material in the wall is cut away to provide the required 18" (457 mm) clearance around the connector. The resulting space must remain empty. A flush-mounted sheet metal cover may be used on one side only. If covers must be used on both sides, each cover must be mounted on noncombustible spacers at least 1" (25 mm) clear of the wall. Your local dealer or your local building inspector can provide details of other approved methods of passing a chimney connector through a combustible wall.

In Canada, this type of installation must conform to CAN/CSA-B365, Installation Code for Solid Fuel Burning Appliances and Equipment.

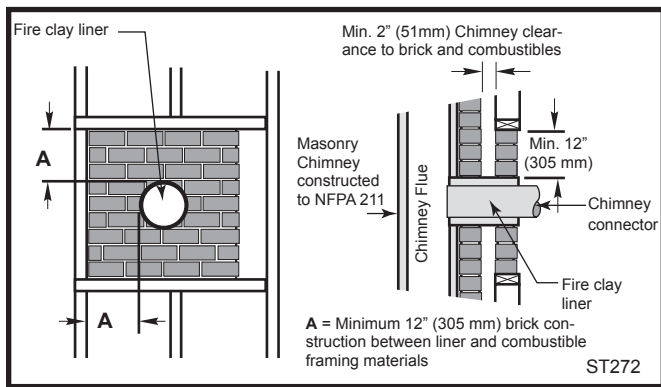

Fig. 9 Masonry Wall Pass-through with single wall chimney connector.

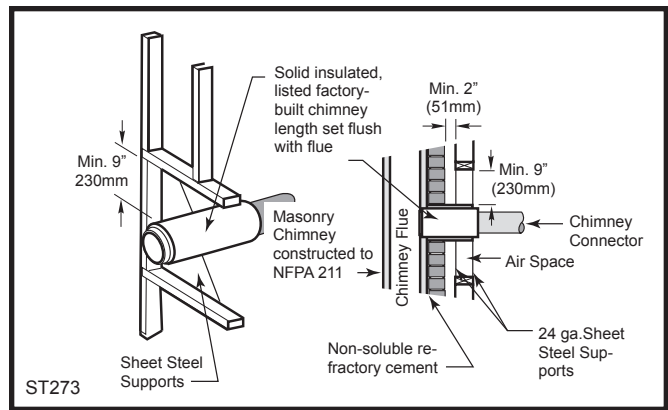

Fig. 10 Wall Pass-through using factory-built insulated chimney section.

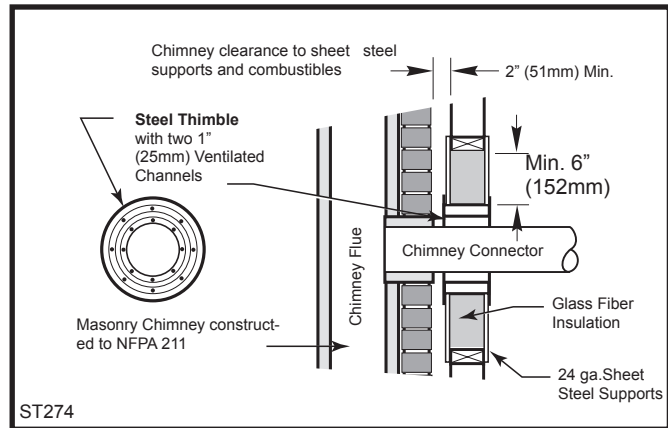

Fig. 11 Wall Pass-through using single wall chimney connector with a ventilated steel thimble.

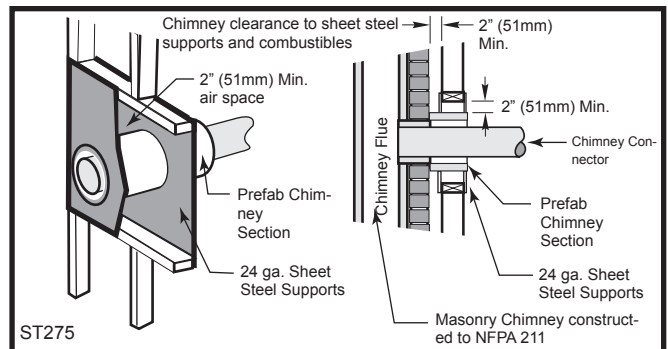

Fig. 12 Wall Pass-through with ventilated steel thimble.

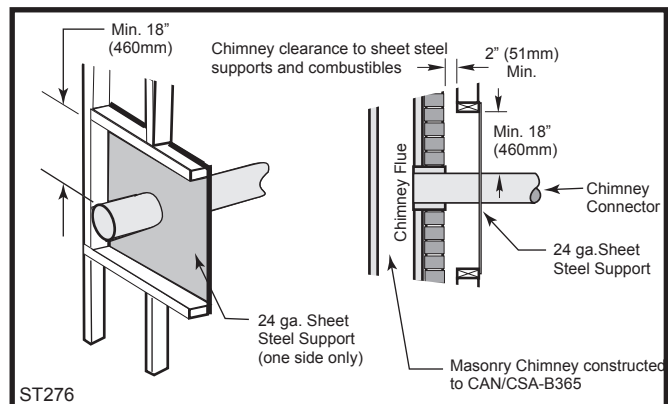

Fig. 13 CSA approved Wall Pass-through.



## Floor Protection

A tremendous amount of heat radiates from the bottom plate of your Aspen. The floor area directly under and around the stove will require protection from radiant heat as well as from stray sparks or embers that may escape the firebox.

Heat protection is provided through the use of a Bottom Heat Shield #1895. Spark and ember protection must be provided by a floor protector constructed with noncombustible material as specified.

Most installations will require that the bottom heat shield be attached. Only when the stove is placed on a completely noncombustible surface such as unpainted concrete over earth may it be used without the heat shield.

Even when the bottom heat shield is installed, you must provide special protection to the floor beneath. For installations with the heat shield attached, use a non-combustible floor protector such as 1/4" nonasbestos mineral board or equivalent, or 24 gauge sheet metal. The floor protector may be covered with a noncombustible decorative material if desired. Do not obstruct the space under the heater.

Protection requirements vary somewhat between the United States and Canada as follows:

**U.S. Installations:** The floor protector is required under the stove and must extend at least 16" from the front of the stove (B, Fig. 14), and at least 6" from the sides and rear (A, Fig. 14). It must also extend under the chimney connector and 2" to either side. (C, Fig. 14)

**In Canada:** A noncombustible floor protector is required under the heater. The floor protector must extend 18" (457 mm) to the front (B, Fig. 14) and 8" (203 mm) from the sides and rear. (A, Fig. 14)

## Fireplace Hearth Protection

Do not assume that your fireplace hearth is completely noncombustible. Many fireplace hearths do not satisfy the "completely noncombustible" requirement because the brick or concrete in front of the fireplace opening is supported by heavy wood framing. Because heat is readily conducted by brick or concrete, it can easily pass through to the wood. As a result, such fireplace hearths can be a fire hazard and are considered a combustible floor.

For all fireplace installations, follow the floor protection guidelines described above.

Keep in mind that many raised hearths will extend less than the required clearance from the front of the heater when it is installed. In such cases, sufficient floor protection as described above must be added in front of the hearth to satisfy the minimum floor protector

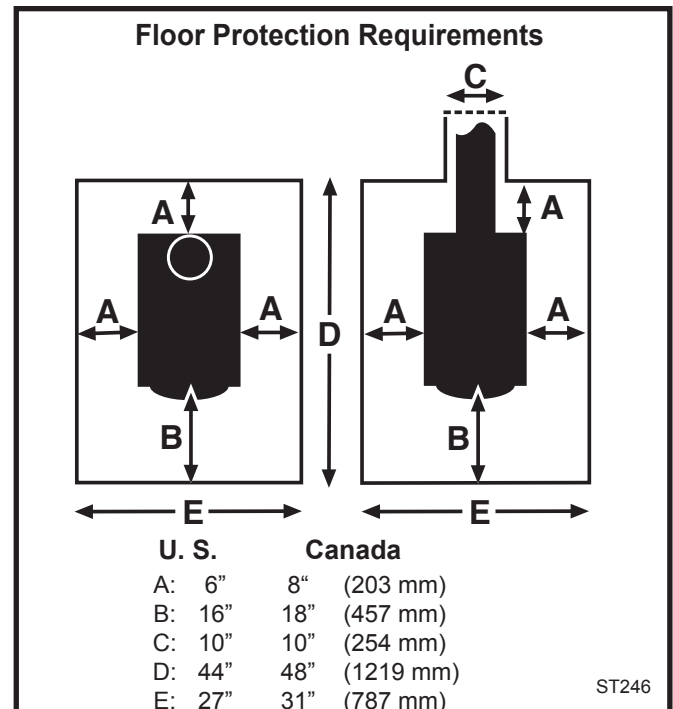

**Fig. 14** These dimensions are minimum requirements only. Use greater dimensions whenever possible.

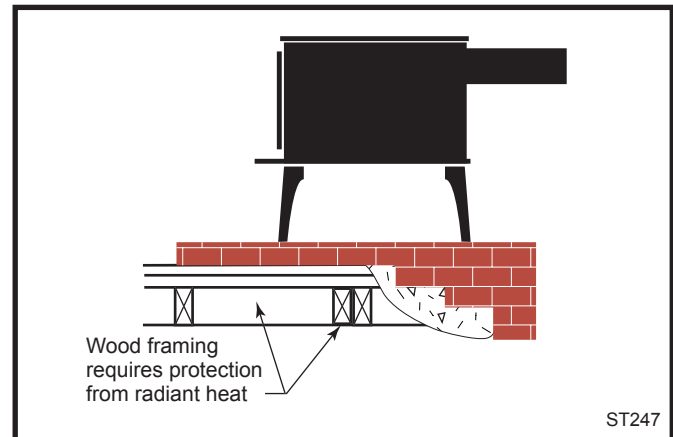

**Fig. 15** Supporting timbers under fireplace hearths are considered to be combustible.

requirement from the front of the stove: 16" (406 mm) from the front in the United States and 18" (457 mm) from the front in Canada.

Hearth rugs do not satisfy the requirements for floor protection as they are only fire-retardant, not fire proof.

Fireplace installations also have special clearance requirements to the side walls, side decorative trim and fireplace mantel. Refer to the information on fireplace and mantel trim shields in this section.

## Mobile Home Installation

The Aspen is approved for use in manufactured (mobile) homes when installed with the optional Mobile Home Kit #1898 in accordance with the instructions provided with that kit and any local codes. This approval applies only in the United States.

In addition to the standard installation requirements described in this manual, the following guidelines apply to mobile home installations:

1. The stove must be permanently secured to the floor using the leg clamps and fasteners provided in the kit.
2. The stove must have a permanent connection to the outside to supply combustion air.
3. The stove must be grounded to the steel chassis of the mobile home.
4. A listed chimney system, including roof thimble, spark arrestor, chimney supports, roof flashing and any other components suitable for use in mobile homes must be used. The chimney system must comply with the standard for Chimneys Factory-Built Residential Type and Building Heating Appliances UL 103.
5. The chimney must be attached directly to the stove and must extend at least 3' (914mm) above the part of the roof through which it passes. The top of the chimney must extend at least 2' (610 mm) above the highest point of any part of the mobile home structure within 10' (3 m) of the chimney.
6. If the chimney exits the mobile home through a wall at a point 7 feet or less above the ground level on which the mobile home is located, a guard or other noncombustible enclosure must be fitted at the point of exit and extend up to a height of 7' (2.1 m). Any openings in this guard must be smaller than 3/4" (19 mm).
7. Check all local building codes, specifically those related to mobile homes. Other requirements may be applicable to chimney system removal for transportation of the mobile home.

**WARNING: Do not install the Aspen in a sleeping room or hallway.**

**CAUTION: The structural integrity of the mobile home roof, floor, walls and ceiling must be maintained.**

## Clearance to Surrounding Combustible Materials

When the stove is operating, both the stoveplate and the chimney connector radiate heat in all directions. A safe installation requires that adequate clearance be maintained between the stove and nearby combustible materials to ensure that those materials do not overheat.

Clearance is the distance between either your stove or chimney connector, and nearby walls, floors, the ceiling, and any other fixed combustible surface. **Keep furnishings and other combustible materials away from the stove as well.** In general, a distance of 48" (1219 mm) must be maintained between the stove and moveable combustible items such as drying clothes, furniture, newspapers, firewood, etc. Keep this area empty of any combustible material.

## Safe Ways to Reduce Clearances

The Aspen clearance requirements, listed and diagrammed on pages 10-11, have been established through testing to UL and ULC standards to meet most installation configurations. These involve four basic variables:

- When the *stove has no listed heat shield* installed.
- When the *stove does have a listed heat shield* mounted on it.
- When the *wall has no listed heat shield* installed.
- When the *wall does have a listed heat shield* mounted on it.

In general, the greatest clearance is required when the stove will be positioned with no heat shield near a wall with no heat shield. The least clearance is required when both the stove and the wall have heat shields. Reducing a stove clearance may require installation of a listed heat shield on the chimney connector as well.

Clearances may be reduced only by means approved by the regulatory authority, or in accordance with the clearances listed in this manual.

When determining clearance, always measure from the top plate of the stove, or, from the chimney connector itself, to the adjacent combustible surface. Do not measure from the heat shields of the stove or connector to the combustible surface.

## Wall Shields

Wall shields should be constructed of 24 gauge or heavier sheet metal, or another noncombustible material such as 1/2" (13mm) insulation board or common brick "laid on flat," with the 3 1/2" (90mm) side down.

Shields must be spaced out from the combustible surface 1" (25mm) on noncombustible spacers. The spacers should not be directly behind the stove or chimney connector.

Air must be able to flow between the wall and the shield. At least 50% of the bottom 1" (25mm) of the shield should be open and the shield must be open at the top.

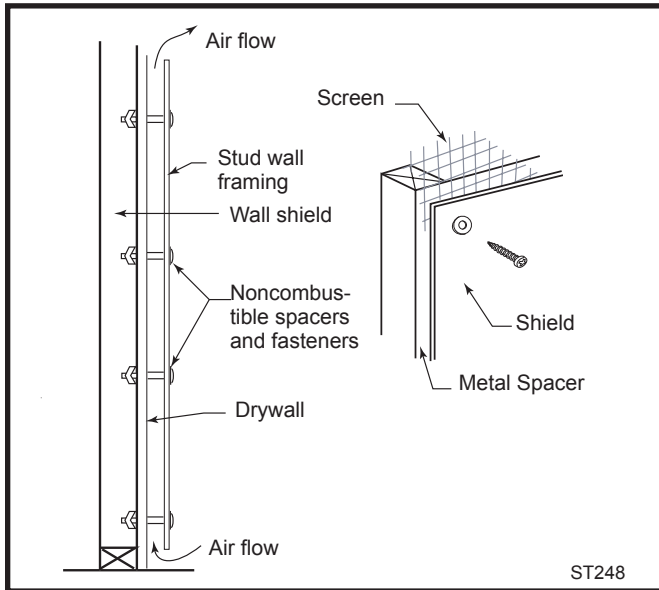

Fig. 16 Approved Wall shield construction

The following examples of wall shield construction illustrate common designs used to safely achieve reduced clearances to combustible wall materials.

**Parallel installation, vertical chimney connector, two wall shields.** Fig. 17: Reduced clearances for both rear and side walls. Wall shields may meet at corner if desired. Shielding for connector is centered behind connector.

**Parallel installation with rear wall pass-through, two wall shields.** Fig. 18: Reduced clearances for both rear and side walls. Wall shields may meet at corner if desired. Shielding for connector is centered behind connector. Wall pass-through must comply with codes.

**Corner installation, vertical chimney connector, two wall shields.** Fig. 19: Reduced side clearances. Wall shields MUST meet at corner.

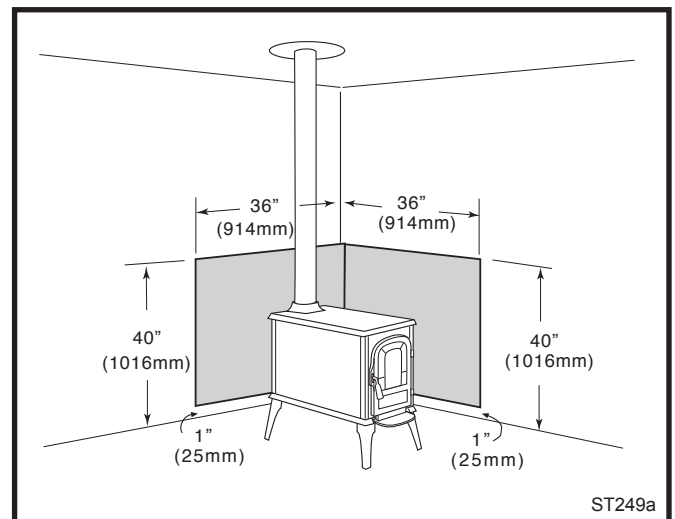

Fig. 17 Parallel installation, vertical chimney connector, two wall shields.

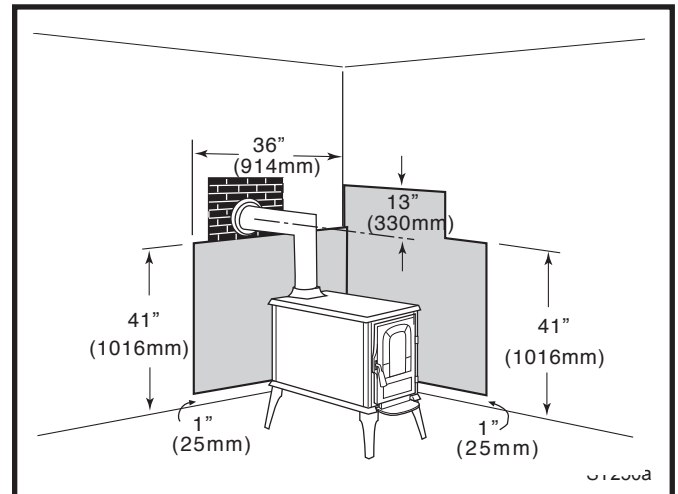

Fig. 18 Parallel installation with rear wall pass-through, two wall shields.

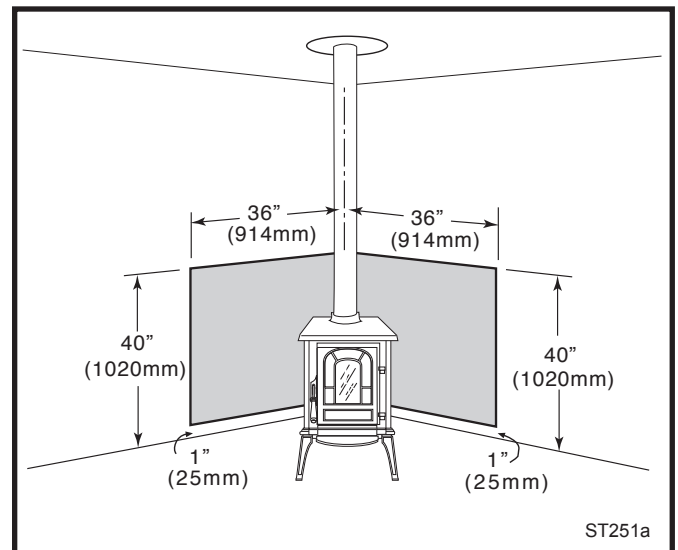

Fig. 19 Corner installation, vertical chimney connector, two wall shields.

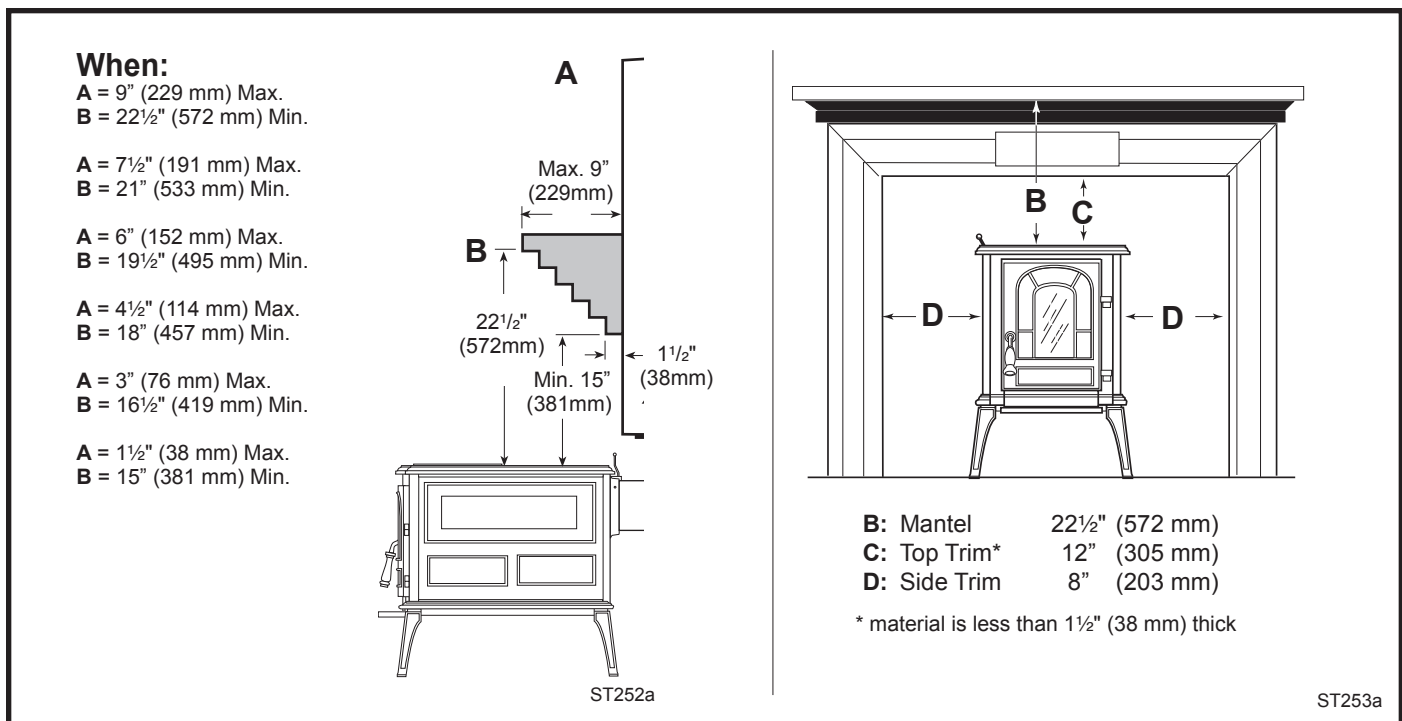

Fig. 20 Mantel and trim clearances.

### Fireplace Clearances

A fireplace installation requires special clearance between the side of the stove and the right and left walls, the side of the stove and the decorative side trim on the fireplace face, and the top of the stove and the mantel.

Maximum Mantel depth (A, Fig. 20) of a combustible mantel is 9" (230 mm). At that depth, the clearance to the stove top (B) must be a minimum of 22½" (572 mm).

Top Trim (C) protruding less than 1½" (38mm) from the face of the fireplace must be a minimum of 12" (305mm) from the stove top. This clearance may not be reduced by shielding.

For every 1½" (38 mm) increment that the trim or mantel extends in depth, the clearance from the stove top must also be increased by 1½" (38 mm).

Side Trim must have a minimum clearance of 8" (203 mm), measured from the stove's top edge. (D, Fig. 20)

### Alcove Clearances

The Aspen is approved for installation into an alcove constructed to maintain the clearances diagrammed in Figure 21.

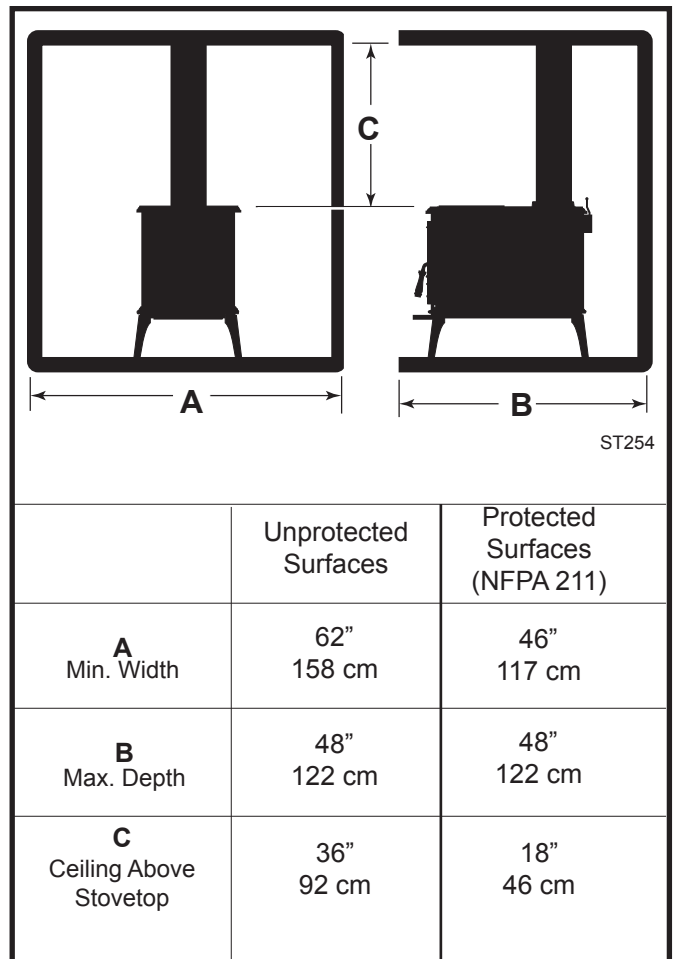

Fig. 21 Alcove Specifications.

## Aspen Clearance Chart

Use the chart below together with the diagrams on the next page to determine the required clearance for your particular installation.

Stove clearances are measured from the top plate to the combustible surface.

Chimney connector clearances are measured from the connector surface and take into account flue collar offset.

<b>Stove Clearance</b>	<b>Unprotected Surfaces</b>			<b>Protected Surfaces</b>		
	<b>Parallel Installation</b>		<b>Corner Installation</b>	<b>Parallel Installation</b>		<b>Corner Installation</b>
	<b>Side</b>	<b>Rear</b>	<b>Corner</b>	<b>Side</b>	<b>Rear</b>	<b>Corner</b>
No Heat Shields	(A) 24" (610 mm)	(B) 13" (330 mm)	(C) 13" (330 mm)	(D) 16" (406 mm)	(E) 9" (230 mm)	(F) 8" (203 mm)
Top Exit, Rear Heat Shield ONLY <sup>1</sup>	(G) 24" (610 mm)	(H) 11" (179 mm)	(I) 13" (330 mm)	(J) 16" (406 mm)	(K) 9" (230 mm)	(L) 8" (203 mm)
Rear Exit, Rear Heat Shield ONLY	(M) 24" (610 mm)	(N) 11" (179 mm)	N/A	(O) 16" (406 mm)	(P) 9" (230 mm)	N/A
Top Exit, Rear H.S., Single-wall, connector shields <sup>1,2</sup>	(Q) 24" (610 mm)	(R) 9" (229 mm)	(S) 13" (330 mm)	(T) 16" (406 mm)	(U) 9" (230 mm)	(V) 8" (203 mm)
Top Exit, Rear H.S., Double-wall connector shields <sup>1,3</sup>	(Q) 24" (610 mm)	(R) 7" (178 mm)	(S) 13" (330 mm)	(T) 16" (406 mm)	(U) 7" (178 mm)	(V) 8" (203 mm)
<b>Chimney Connector</b>	<b>Unprotected Surface / Vertical</b>			<b>Protected Surface / Vertical</b>		
No Heat Shields	15" (381 mm)			11" (279 mm)		
Using Connector Heat Shields <sup>2</sup>	13" (330 mm)			6" (152 mm)		
Double Wall Connector <sup>3</sup>	6" (152 mm)			6" (152 mm)		
	<b>Unprotected Surface / Horizontal</b>			<b>Protected Surface / Horizontal</b>		
Single Wall Connector	18" (457 mm)			11" (279 mm)		
Double Wall Connector	6" (152 mm)			6" (152 mm)		
<b>Front Clearance to Combustibles</b>	<b>All Installations</b> 48" (1219 mm)					
<p>** A distance of 48" must be maintained between the stove and moveable combustible items such as drying clothes, furniture, firewood, etc.</p> <p><sup>1</sup> When a rear heat shield is installed on a top exit stove, the shield insert must be attached to the shield so the area behind the flue collar on the stove is protected.</p> <p><sup>2</sup> Chimney connector heat shields must extend exactly 24" (610 mm) above the top of the stove. No shielding can be used on the connector above 24" (610 mm). The unshielded chimney connector above the 24" (610 mm) point must be 13" (330 mm) from an unprotected wall.</p> <p><sup>3</sup> In top exit installations, this clearance requires the use of the rear stove heat shield with the flue collar cover plate installed.</p>						

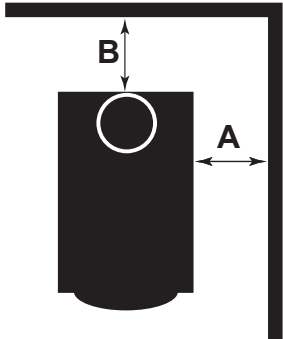
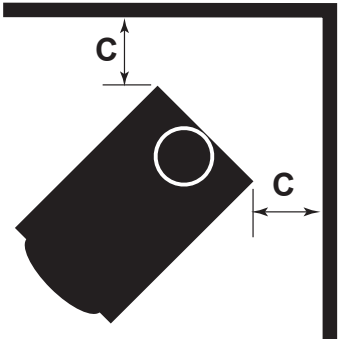
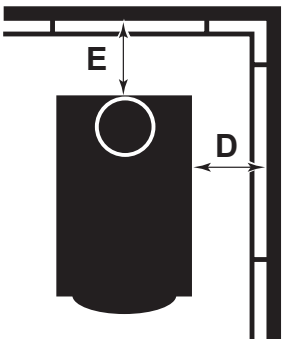
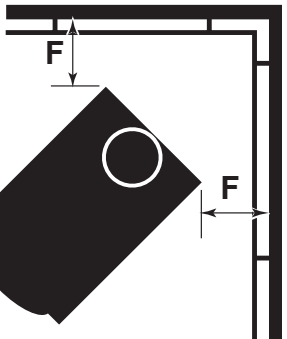
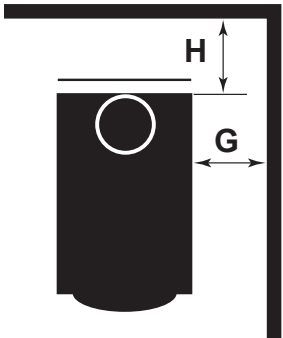
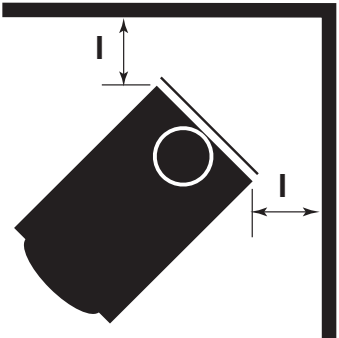
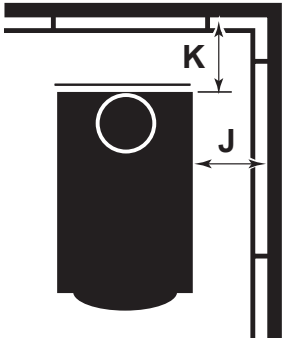
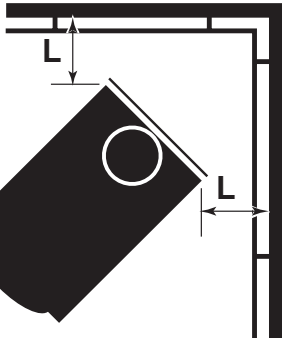
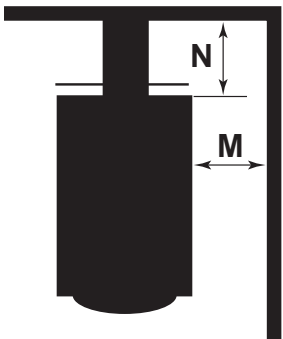
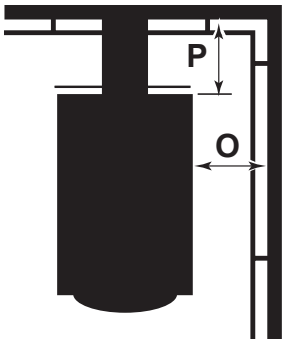
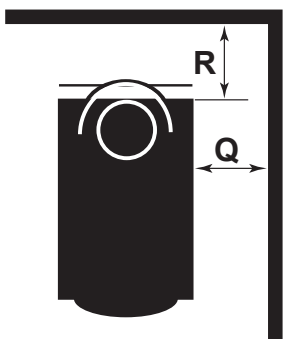
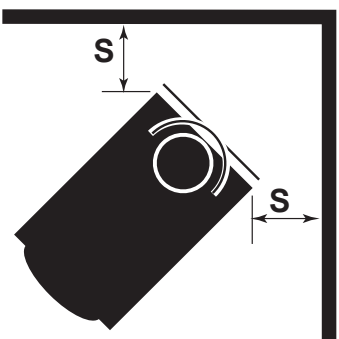
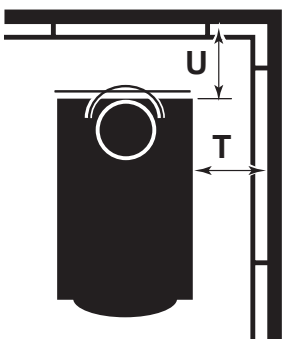
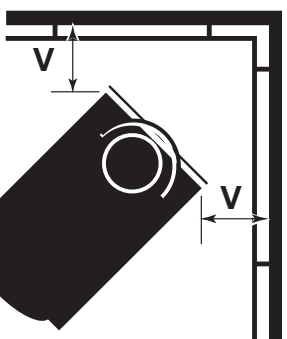

UNPROTECTED SURFACES		PROTECTED SURFACES	
Stove Installed Parallel to Wall	Stove in Corner	Stove Installed Parallel to Wall	Stove in Corner
 <p>Top Exit, No Heat Shields</p>			
 <p>Top Exit, Rear Heat Shield only</p>			
 <p>Rear Exit, Rear Heat Shield only</p>	<p>NA</p>		<p>NA</p>
 <p>Top Exit, Rear Heat Shield and single-wall connector w/ shields, or double-wall connector</p>			

## Assembly

You will need the following tools to assemble the Aspen:

- 9/16" open end wrench
- safety glasses & gloves
- flat head screwdriver
- power drill w/ 1/8" (3mm) bit
- stub handle phillips screwdriver
- 7/16" open end wrench (for Ashlip & Outside Air Adapter)

### Unpack the Stove

1. Remove the shipping straps and plastic wrap.
2. Inspect the stove and contents for shipping damage or missing parts. Immediately notify your dealer of any damage. Do not install this stove if any damage is evident or any parts are missing.

#### Hardware Bag contents:

- Stove Legs, 4
- Hex Head Leg bolts with washers, 4
- #10 x 1/2" sheet metal screws, 3
- Owner's Registration Card
- Touch-up Paint (Porcelain enamel stoves only)

### Install Stove Legs

Leg installation will be accomplished most easily with the help of an assistant who can tilt the stove onto its side while you attach the legs.

1. With your assistant holding the stove up on its side, remove the slotted screws from the leg mounting holes at each corner of the stove bottom.
2. Install two legs, using the hex head bolts with washers from the parts bag. The shoulder of the legs should seat within the locator bosses cast into the stove bottom at each corner. (Fig. 22) Tighten the bolts with the wrench. **CAUTION: Overtightening can strip tapped threads.**
3. With your assistant, lift the stove up onto its legs and hold it in a tilted position to install the remaining two legs with washers and hex bolts.

### Install the Ashlip

Use a 7/16" wrench to secure the Ashlip to the stove bottom with two, 1/4-20 x 5/8" hex head screws and washers found in the holes used to attach the ashlip. (Fig. 23)

### Install the Outside Air Adapter

The optional #1897 Outside Air Adapter provides a collar to which a 3 inch diameter air duct may be attached directly to the air inlet area at the back of the stove. The adapter should be attached to the stove before a bottom or rear heat shield is installed.

1. Remove the phillips head screw located just above the primary air inlet at the back of the stove.

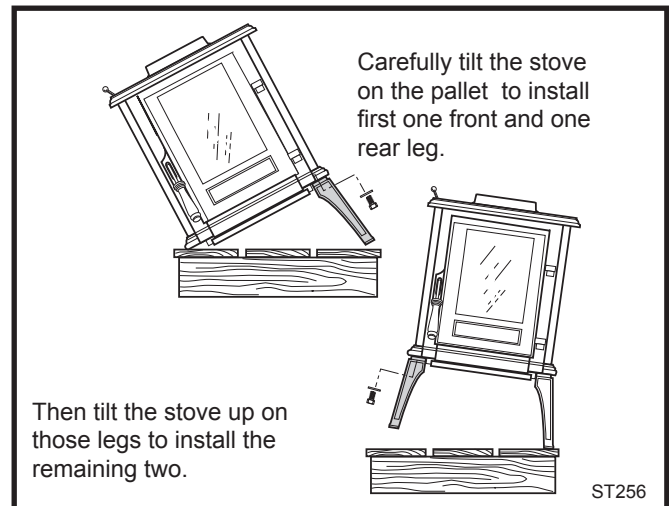

Fig. 22 Install legs on one side of stove then the other.

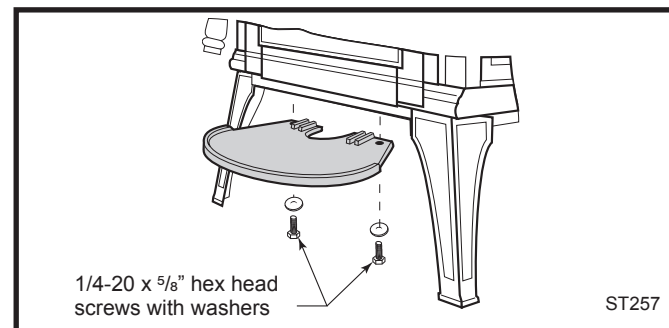

Fig. 23 Attach the Ashlip to the bottom plate.

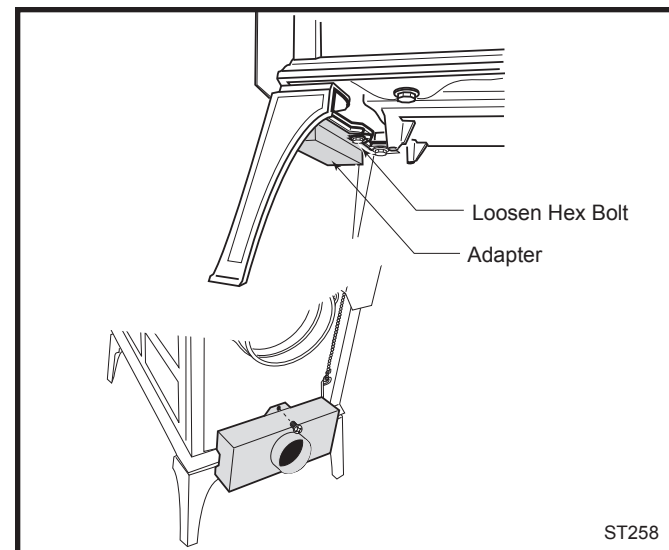

Fig. 24 Attach the adapter to the bottom plate.

2. Locate the hex bolt (Fig. 23) located in the center rear edge of the stove bottom plate. Loosen this bolt just enough to engage the Adapter clevis tab under the washer and then retighten.

3. If you are not installing a Rear Heat Shield, use the phillips head screw to secure the upper flange of the Adapter to the stove at the hole from which the screw was removed in Step 1. (Fig. 24) Otherwise, a heat shield spacer will be used here. (See “Install the Rear Heat Shield”, below.)

### Flue Collar Reversal

If a rear exit chimney connection is required, you will need to remove the flue collar from the stove top and move it to the back of the stove. (Fig. 25)

1. Use a phillips screwdriver to remove the two screws and rear cover plate from the back of the stove.
2. Remove the flue collar by removal of the two phillips screws from the top of the stove.
3. Attach the cover plate to the stove top. Be sure to keep the gasket in place.
4. Secure the flue collar to the back of the stove.
5. Insert the crimped end of the first section of chimney connector into the flue collar. Using the holes in the collar as guides, drill 1/8" (3mm) holes through the connector pipe. Use the three #10 x 1/2" sheet metal screws provided to secure the chimney connection to the flue collar.

### Install the Rear Heat Shield

The #1896 Rear Heat Shield reflects radiant heat away from combustible materials located behind the stove. Its use enables you to install the stove at a reduced clearance to combustible materials in accordance with the specifications in this manual.

1. Remove the three phillips head screws from the back of the stove. The upper right screw also serves to secure the thermostat cover to the stove. (Fig. 26)
2. Thread the three 1 1/4" spacers provided with the heat shield kit into the holes. Be sure to re-secure the thermostat cover using a spacer at that location. If the Outside Air Adapter is used, secure its upper flange to the hole above the primary air inlet using a spacer instead of the screw. Hand tighten the spacers.
3. Align the holes in the heat shield with the spacers and secure the shield to the spacers using the three phillips head screws previously removed. Tighten firmly with a screwdriver.

### Install the Bottom Heat Shield

The #1985 Bottom Heat Shield must be used in the U.S. and Canada in any installation on a floor that is not composed of unpainted cement on earth.

1. Remove the 1/4-20x 3/8" phillips screw from the central mounting boss in the stove bottom. (Fig. 27)
2. Mount the bottom heat shield to the stove bottom using the same phillips head screw previously removed. The shield will butt against the cast bosses in the bottom of the ashlip at the front of the stove.

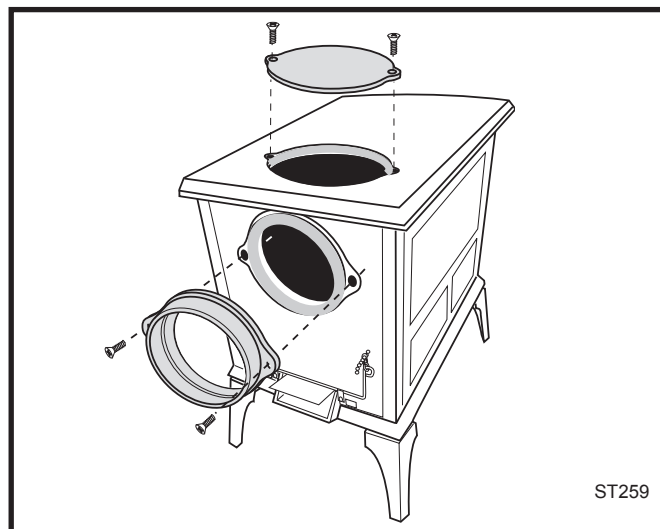

Fig. 25 Reversing the flue collar.

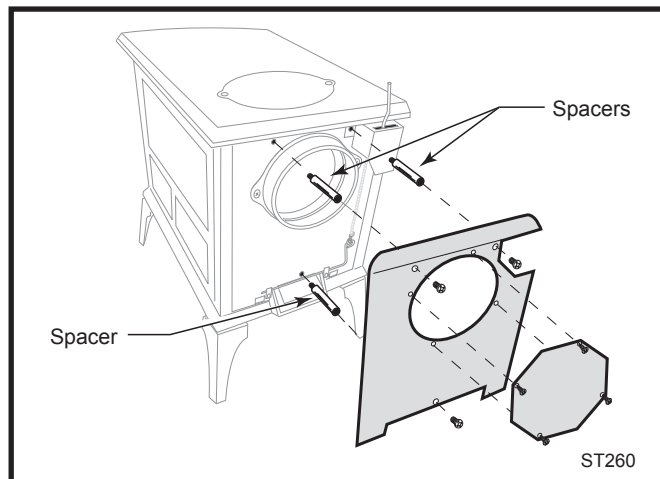

Fig. 26 Install the rear heat shield.

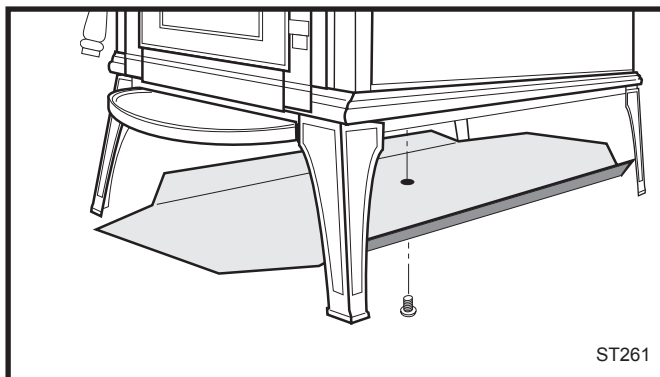

Fig. 27 Install the bottom heat shield.

## Operation

### How the Aspen Works

Combustion control is achieved in the Aspen through two separate air delivery systems.

The **primary air control lever**, located at the left rear corner of the stove, controls the amount of incoming primary air for starting, maintaining, and reviving the fire. More air entering the stove makes the fire burn hotter and faster, while less air prolongs the burn at a lower heat level.

For the greatest air supply and maximum heat output (but the shortest burn time), move the lever to the straight up (12 o'clock) position. For a fire that will last longer with less heat, move the lever to the right. You can set the lever anywhere in between the left and right extremes.

The Aspen features an automatic thermostat to ensure an even heat output at any manual setting you select. As the fuel burns, the thermostat reacts to the heat radiating from the stove surface and, consequently, adjusts the air shutter attached to it. As the fire intensity (and heat output) builds, the thermostat slowly closes the air shutter, thereby restricting incoming combustion air. As the fire intensity then wanes (and heat output lessens), the thermostat responds and gradually opens the air shutter which allows more combustion air to again enliven the fire. This ebb and flow action functions continuously to prolong the burn cycle until the fuelbed is exhausted.

**DO NOT USE CHEMICALS OR FLUIDS TO START THE FIRE. DO NOT BURN GARBAGE OR FLAMMABLE FLUIDS SUCH AS GASOLINE, NAPHTHA, OR ENGINE OIL. Also, never use gasoline-type lantern fuel, kerosene, charcoal lighter fluid, or similar liquids to start or "freshen up" a fire. Keep all such liquids well away from the Aspen while it is in use.**

**Caution: the Aspen will be hot while in operation. Keep children, clothing and furniture away. Contact may cause skin burns.**

**DO NOT OVERFIRE THIS HEATER. Overfiring may cause a house fire, or can result in permanent damage to the stove. If any part of the stove glows, you are overfiring.**

Another separate supply of oxygen is delivered to the upper area of the firebox to support combustion of gases released from the main fuel bed. This **Secondary Air** enters the stove through two, unrestricted inlets and is heated while passing through separate channels before being delivered through three stainless steel multi-ported tubes located at the top of the firebox.

### Burn Only High-Quality Wood

**THE ASPEN IS DESIGNED TO BURN NATURAL WOOD ONLY; DO NOT BURN ANY OTHER FUELS.**

You will enjoy the best results when burning wood that has been adequately air-dried. Avoid burning "green" wood that has not been properly seasoned. The wood should be no longer than 16" (410 mm) in length, however, you will find that shorter wood lengths ease refueling and promote the most efficient combustion.

The best hardwood fuels include oak, maple, beech, ash, and hickory that has been split, stacked, and air-dried outside under cover for at least one year.

For areas that do not have a supply of hardwood, commonly burned softwoods include tamarack, yellow pine, white pine, Eastern red cedar, fir, and redwood. These too should be properly dried.

Keep wood a safe distance from the heater and keep it out of the areas around the heater used for refueling and ash removal.

### Use the Air Control Setting that Works Best for You

No single air control setting will be appropriate for every situation. Settings will differ depending on the quality of the fuel, the amount of heat desired, and how long you wish the fire to burn.

The control setting also depends on your particular installation's "draft," or the force that moves air from the stove up through the chimney. Draft is affected by such things as the length, type, and location of the chimney, local geography, nearby obstructions, and other factors.

Too much draft may cause excessive temperatures in the Aspen, and could even damage it. On the other hand, too little draft can cause backpuffing into the room and/or the "plugging" of the chimney.

How do you know if your draft is excessively high or low? Symptoms of too much draft include an uncontrollable burn or a glowing-red stove part. A sign of inadequate draft is smoke leaking into the room through the stove or chimney connector joints, low heat, and dirty glass.

In newer homes that are well-insulated and weather-tight, poor draft may result from insufficient air in the house. In such cases, a slightly opened window or door, near the stove on the windward side of the house will provide the fresh air needed.

A more effective option for delivering ample combustion air to the stove is to duct air directly from outdoors to the stove. In fact, in some areas, provisions for outside combustion air are required in all new construction. The optional Aspen Outside Air Adapter #1897 is available from your dealer.

When you first begin using the stove, pay attention to the air control settings. You will quickly find that a specific setting will give you a fixed amount of heat. It may take some time to determine the amount of heat and the length of burn you should expect from various settings.

**Do not for any reason attempt to increase the firing of your heater by altering the air control adjustment range outlined in these directions.**

Use the following air control settings as a starting point to help determine the best settings for your installation. (Fig. 28)

#### Aspen Control Settings

<u>Burn Rate</u>	<u>Primary Air Control</u>
High	From 12:00
	Medium From 1:00
Low	From 2:00

Before you start using the stove, please read the Appendix on Draft Management starting on page 24 to learn how the characteristics of your installation will affect the stove's performance. You and the stove are parts of a system, and other parts of the system have a strong effect on operation; you may need to vary your firing technique to get the performance you want.

### Starting and Maintaining a Fire

#### Conditioning Your Stove

Cast iron is extremely strong, but it can be broken with a sharp blow from a hammer or from the thermal shock of rapid and extreme temperature change.

The cast plates expand and contract with changes in temperature. When you first begin using your Aspen, minimize thermal stress by allowing the plates to adjust gradually during three or four initial break-in fires following **Steps 1-3**.

**BURN SOLID WOOD FUEL ONLY, AND BURN IT DIRECTLY ON THE GRATE. DO NOT ELEVATE THE FUEL. DO NOT BURN COAL OR OTHER FUELS.**

**WARNING: OPERATE THIS STOVE ONLY WITH THE DOOR FULLY CLOSED.**

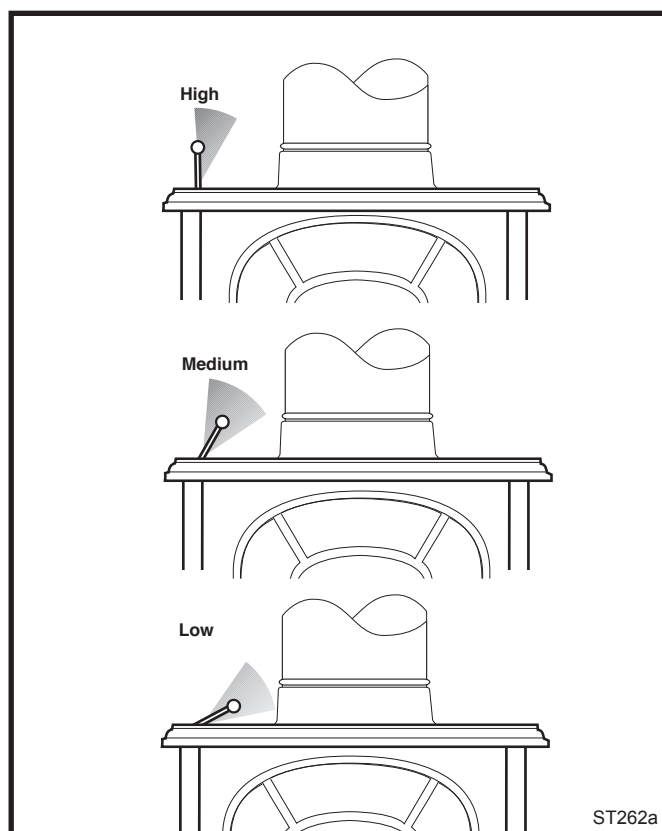

Fig. 28 Air inlet shutter settings; Low - Medium - High.

**The Primary Air Inlet must be fully open when starting a fire or when refueling.**

- Step 1. Open the primary air control fully.
- Step 2. Place several sheets of crumpled newspaper in the stove. Avoid using glossy or colored paper, as these burn poorly. At the front of the firebox, place on the paper six or eight pieces of dry kindling split to a finger-width size, and on the kindling lay two or three larger sticks of split dry wood approximately 1-2" (25-51 mm) in diameter.

Step 3. Light the newspaper and close the door. Gradually build up the fire by adding a few 3-5" (80-120 mm) diameter splits. **If this is one of the first few "break-in" fires, let the fire burn brightly, and then let it die out.**

- During the break-in fires, don't let the stove get hotter than 500°F. (260°C) as measured on an optional stove-top thermometer. Adjust the air control lever as necessary to control the fire.
- Some odor from the stove's hot metal, the paint, and the cement is normal for the first few fires.

**NOTE:** Some chimneys need to be "primed," or warmed up, before they will draw sufficiently to sustain a fire. To correct this situation, roll up a couple pieces of newspaper, place them on top of the kindling and toward the back of the stove, light them, and close the door. This should heat the chimney enough to initiate strong draft.



Once the draft is established, open the front door and light the rest of the fuel bed at the bottom. Do not light the main bed of fuel until the chimney begins drawing.

**Step 4. After the stove has been broken-in** using Steps 1-3, continue to build the fire gradually. Add larger wood with a diameter of 3-4" (75-102 mm). Continue adding split logs of this size to the briskly-burning fire until there is a glowing ember bed at least 2" (51 mm) deep. A good ember bed is necessary for proper functioning and may take up to an hour to establish.

**Step 5.** Adjust the thermostatic air control for the desired heat output.

### Refuel While the Embers Are Still Hot

Reload the Aspen while it is still hot and there are plenty of glowing embers to re-kindle the fire. Include some smaller pieces of wood in the new load of fuel to help the stove return to its operating temperature quickly. Wear stove gloves, and follow this procedure when you reload your stove:

**Step 1.** Open the thermostat lever.

**Step 2.** Open the door and check the ash level in the ash pan. If necessary, dispose of the ashes and replace the pan.

**Step 3.** Use a fireplace tool to break up the charcoal and direct ash through the grate. Pull the charcoal from the back to the front. This will encourage efficient combustion as the fuel burns from front to rear. (Fig. 31)

**Step 4.** Load wood — smaller, split pieces first. Close the door. Ideal performance will be achieved by operating with the air control set in the maximum (HIGH) position for several minutes after refueling. Reset the primary air control for the desired heat output after the fire is re-established.

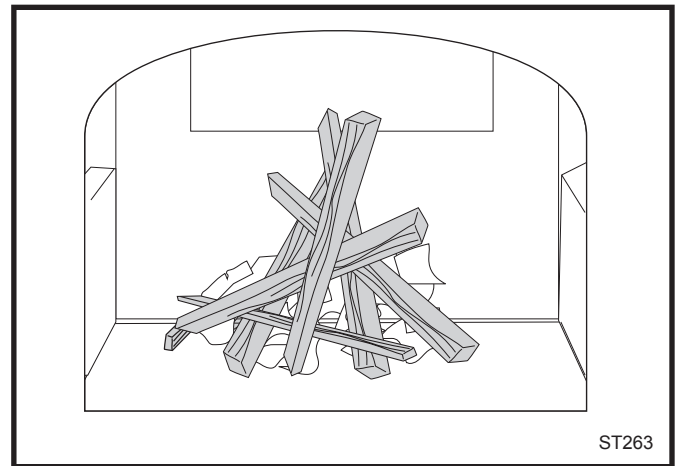

**Fig. 29** Start a fire with small, dry kindling.

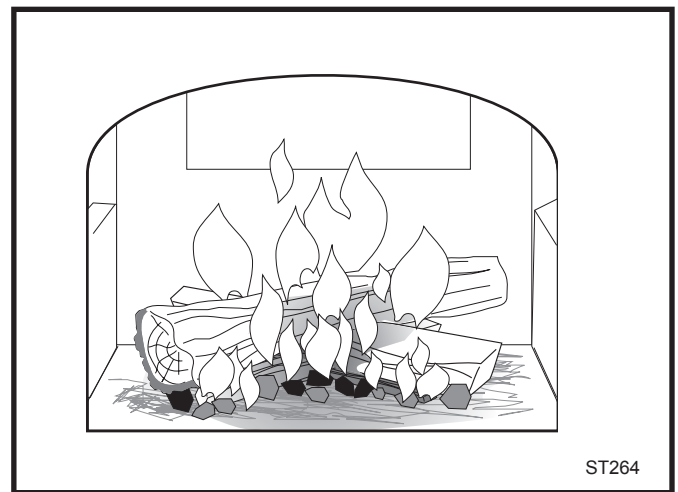

**Fig. 30** Gradually add larger pieces of wood until all the wood is burning well.

## Ash Disposal

Remove ash before it reaches the top of the ash pan. Check the level at least once a day, and before each re-fueling. Using stove gloves, pull the ash pan out of the stove by its handle. Remove the ash pan and properly dispose of the ashes. Be sure to keep the pan level during disposal.

Empty the ash pan regularly, typically every one to three days. The frequency will vary depending on how you operate your Aspen; if you burn more wood at higher heat output settings, ash will accumulate rapidly.

Dispose of ashes into a metal container with a tight-fitting lid kept outdoors. Put the closed container of ash on a noncombustible floor or on the ground, well away from all combustible materials, pending final disposal. If the ash is disposed of by burial in soil or otherwise locally dispersed, keep it in the closed container until all cinders have thoroughly cooled. You can use wood ash as a garden fertilizer.

**CAUTION:** Never use your household or shop vacuum cleaner to remove ash from the stove; always remove and dispose of the ash properly.

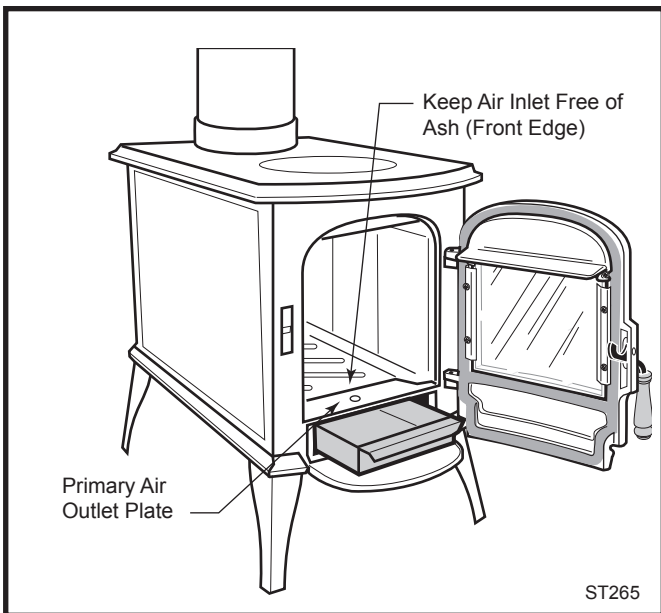

**Fig. 31** Primary air outlet - keep clear of ash and charcoal accumulation.

**IMPORTANT:** A critical source of air into the Aspen firebox is located in front of the ash grate as shown in Figure 31. If this air slot becomes plugged with ash, a sluggish, cool fire and dirty glass will result. Keep this air slot clear of ash. Refer to the Maintenance section for instructions to more thoroughly clean ash from beneath the primary air plate.

**CAUTION: AVOID SLAMMING THE STOVE DOOR OR STRIKING THE GLASS PANEL. DO NOT OPERATE THE STOVE WITH THE GLASS PANEL MISSING, DAMAGED, OR BROKEN. DO NOT INSTALL SUBSTITUTE MATERIALS. SEE MAINTENANCE SECTION FOR REPLACEMENT INSTRUCTIONS.**

## Smoke Detectors

The use of smoke detectors throughout the home is strongly advised, if not required by building codes or insurance regulations. It is a good idea to install a smoke detector in the living areas and each bedroom.

You may not, however, wish to install a detector in the immediate vicinity of the stove. Depending on the sensitivity of the unit, the alarm can be set off while you are tending the fire or emptying the ashes. If you install a detector in the same room, locate it as far away from the stove as possible.

## Maintenance

Let the fire in the stove go out and allow the stove to cool completely before beginning any maintenance procedure.

### Care of the Cast Iron Surface

An occasional dusting with a dry rag will keep the painted cast iron of your Aspen looking new. The stove's paint can be touched up as needed. First, clean the areas to be painted with a wire brush. Then, touch up the stove with high temperature stove paint. Apply the paint sparingly, and keep in mind that two light coats of paint are better than a single heavy one.

### Care of Porcelain Enamel Finish

Use a dry or slightly damp rag or a soft brush to remove spills or stains. For difficult jobs that require a cleaning agent, use only a kitchen appliance cleaner or polish recommended for use on enamel surfaces.

### Cleaning the Glass

Most of the carbon deposits on the glass will burn off during hot fires. However, the ash residue that accumulates on the glass surface should be removed regularly to prevent etching. Follow this procedure to clean the glass:

- Be sure the glass is completely cool.
- Clean the glass with water or a cleaner made especially for this purpose. Do not use abrasive cleaners.
- Rinse the glass thoroughly.
- Dry the glass completely.

### Glass Replacement

Replace glass only with MHSC part no. 30000362. The glass panel rests on a cushion provided by three flat gaskets, and is held in place by two clips. (Fig. 32) The glass is coated on one side which is slightly colored. Remove the door from the stove and place it on a sturdy, level work surface. Use a towel to protect the porcelain enamel finish.

1. Remove the Door Manifold. (Two phillips head screws).
2. Remove the Retainer Clips. (Two phillips head screws on each clip).
3. Inspect the Gasket. If the window gasket is in good condition, you can leave it in place. If you replace it, use only MHSC gaskets (two vertical- PN 30000383; one horizontal- PN 30000384). Be sure the channel around the window opening is clean, and free of dust.

Place the three flat gaskets (two vertical, one horizontal) into the panel inset as shown in Figure 32.

4. Install the Glass. Lay the glass on the inner gasket with the coated side down (toward the outside of the door). Tighten the screws snugly, but loose enough to allow for a little movement of the glass when the stove is in operation. Overtightening can crack the glass immediately or cause it to crack if it is unable to expand when hot.

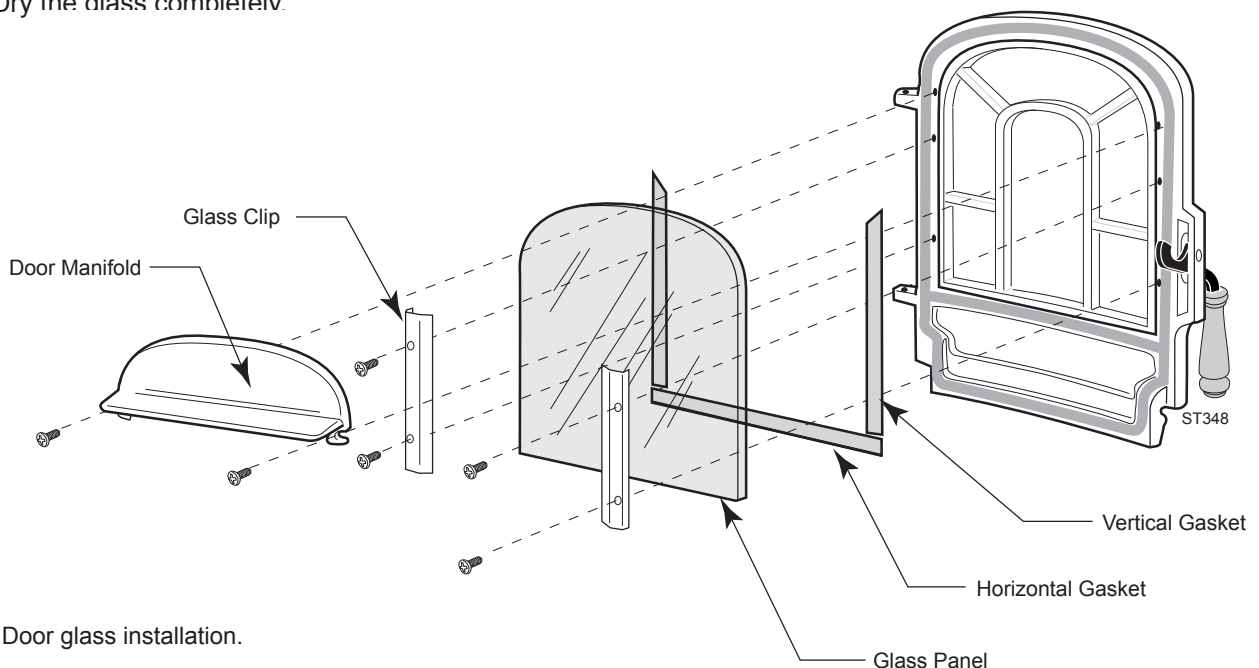

Fig. 32 Door glass installation.

## Gasket Replacement

Your Aspen uses rope-type fiberglass gaskets to make a tight seal between some parts. With use, particularly on those parts that move, gaskets can become brittle and compressed and can begin to lose their effectiveness. These will need periodic replacement.

The sizes of replaceable gasket are listed below, along with their applications.

Gasket Diameter...	...And the Parts it Seals
5/16" Round	Flue Collar Gasket
3/8" Round	Top
7/16" Round	Door Gasket
1/2" Flat, two	Vertical Gasket for glass
1/2" Flat	Horizontal Gasket for glass

Wait until the fire is out and the stove has cooled. Be sure to follow the standard safety procedure for working with dusty materials: Wear safety goggles and a dust mask.

Step 1. Remove the existing gasket by grasping an end and pulling firmly.

Step 2. Use a wire brush or a screwdriver to clean the channel of any remaining cement or bits of gasket. Remove stubborn deposits of cement with a cold chisel if necessary.

Step 3. Determine the correct length of the appropriate-sized gasket by laying it out in the channel. Allow an extra 1-2" (25-51 mm), and mark the spot to be cut.

Step 4. Remove the gasket from the channel, place it on a wood cutting surface, and cut it at the marked spot with a utility knife.

Twist the ends slightly to discourage the gasket from unraveling.

Step 5. Lay an unbroken 1/8" (3 mm) bead of gasket cement in the newly-cleaned channel.

Step 6. Starting at one end, press the gasket into the channel.

Ensure a good joint where the gasket meets before trimming any excess. Do not overlap the gasket ends or leave ends with ragged edges.

Step 7. Press the gasketed part firmly against its normal mating surface to seat the gasket evenly in its channel. Close and latch the door to do this; close the door on a piece of waxed paper to keep the cement from migrating onto the non-gasketed part, or tap other parts

Step 8. Clean excess cement from around the channel. Let the cement that holds the new gasket dry thoroughly.

## Adjust the Door

The door latch may need adjustment as the gasket material compresses over time. The latch engagement may be tightened by removing the shim washers that are under the Latch Plate. (Fig. 33) Remove only one pair at a time. When a tight engagement can no longer be achieved with no shim washers in place, the entire door gasket should be replaced. Use only MHSC part no. 700-0910.

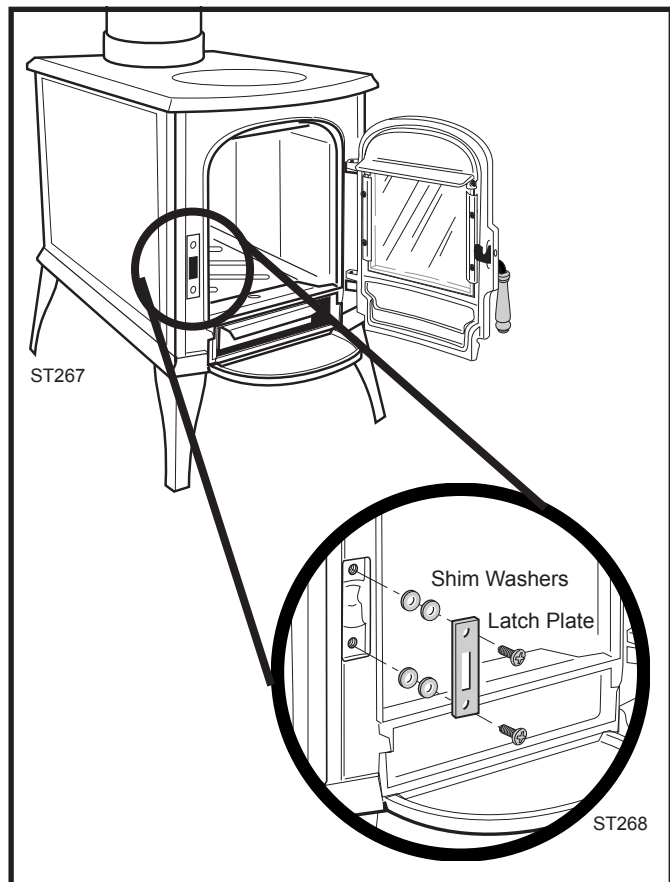

Fig. 33 Remove shim washers to tighten latch engagement.

## The Chimney System

### Creosote

Your Aspen is designed to reduce creosote buildup significantly. However, regular chimney inspection and maintenance must still be performed. For safety, good stove performance, and to protect your chimney and chimney connector, inspect your chimney and chimney connector on a regular schedule. Clean the system if necessary. Failure to keep the chimney and connector system clean can result in a serious chimney fire.

**When wood is burned slowly, it produces tar, organic vapors and moisture that combine to form creosote. The creosote vapors condense in the relatively cool chimney flue. As a result, creosote residue accumulates on the flue lining. When ignited, this creosote makes an extremely hot fire within the flue system that can damage the chimney and overheat adjacent combustible material.**

**If you do have a chimney fire, promptly:**

- **Close the damper and thermostat lever.**
- **Get everyone out of the house.**
- **Call the Fire Department.**

You should inspect the system every two weeks during the heating season as part of a regular maintenance schedule. To inspect the chimney, let the stove cool completely. Then, using a mirror and a strong light, sight up through the flue collar into the chimney flue. If it is not possible to inspect the flue system in this fashion, the stove must be disconnected to provide better viewing access.

If a significant layer of creosote has accumulated — 1/8" (3 mm) or more — remove it to reduce the risk of a chimney fire.

Clean the chimney using a brush the same size and shape as the flue liner. Flexible fiberglass rods are used to run the brush up and down the liner, causing any deposits to fall to the bottom of the chimney where they can be removed through the clean-out door.

The chimney connector should be cleaned by disconnecting the sections, taking them outside, and removing any deposits with a stiff wire brush. Reinstall the connector sections after cleaning, being sure to secure the individual sections with sheet metal screws.

If you cannot inspect or clean the chimney yourself, contact your local Vermont Castings' Authorized Dealer or hire a professional chimney sweep.

## Annual Maintenance

Perform a thorough cleaning, inspection and repair each Spring, at the end of the heating season.

- Thoroughly clean the chimney and chimney connector.
- Inspect the chimney for damage and deterioration. Replace weak sections of prefabricated chimney. Have a mason make repairs to a masonry chimney.
- Inspect the chimney connector and replace any damaged sections.
- Clean ash debris from under the primary air plate. See procedure below.

- Check gasketing for wear or compression, and replace if necessary. A 'paper test' will guide you on this. Close and lock the door or damper on a slip of paper and then try to pull the paper out. If the paper pulls out with little or no resistance, the gasket isn't snug enough at that spot. If adjusting the damper or latch doesn't result in a seal that makes it hard to pull the paper out, replace the gasketing.
- Check door handle for tightness. Adjust if needed.
- Check heat shield screws. Tighten as necessary.
- Clean dust from the inner sides of bottom, rear and connector heat shields.
- Remove ashes from the ash pan and replace with moisture absorbing material (such as cat litter) to keep the stove interior dry. Close the stove door to keep cats from using the litter.
- Touch up the paint on black stoves.

## Clean the Primary Air Outlet

Ash accumulation below the primary air plate will eventually result in sluggish, cool fires. Ash accumulation should be removed at least yearly as follows:

1. Remove the phillips head screw that retains the Primary Air Plate. (Fig. 34)
2. Use a screwdriver to pry the plate out of the cemented seams.
3. Remove ash debris from the cavity.
4. Use high-temperature furnace cement to reseal the front seam and side seams and replace the plate. Secure with the phillips head screw.

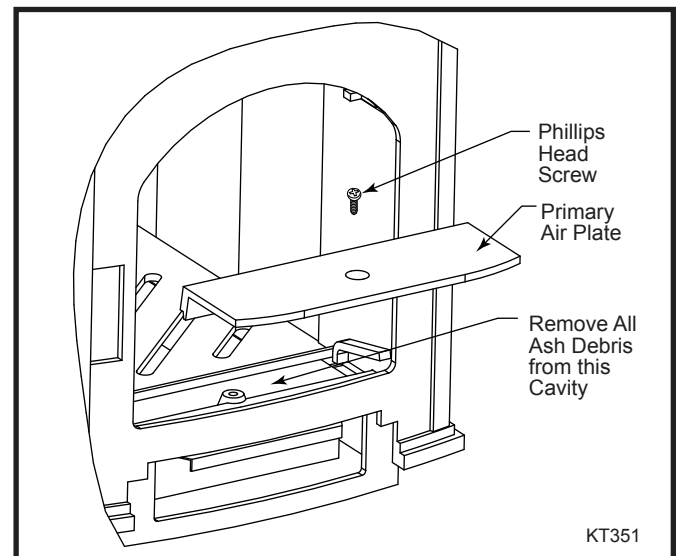

**Fig. 34** Remove phillips head screw and primary air plate to clean ash from cavity.



## Draft Management

Your stove is only one part of a system that includes the chimney, the operator, the fuel and the home. The other parts of the system will affect how well the stove works. When there is a good match between all the parts, the stove works well.

Wood stove operation depends on natural (unforced) draft. Natural draft occurs when exhaust gas is hotter (and therefore lighter) than the outdoor air at the top of the chimney. The greater the temperature difference, the stronger the draft. As the hot exhaust gas rises out of the chimney it generates suction that draws air into the stove for combustion. A slow, lazy fire with the stove's air inlets fully open indicates a weak draft. A brisk fire, supported only by air entering the stove through the normal inlets, indicates a good draft. The inlets are passive; they regulate how much air can enter the stove, but they do not move air into it.

The efficiency of a modern woodburning appliance, (in which the amount of air available for combustion is regulated), depends on the chimney to keep exhaust gases warm all the way outdoors. The characteristics of your chimney - whether it is steel or masonry, interior or exterior, matched or mismatched to the stove collar - determine how quickly it will warm up and how well it will sustain the optimum temperatures necessary to maintain strong draft and efficient combustion. Here follows a description of various flue system characteristics and related effects on stove performance.

### Masonry Chimney

Although masonry is the traditional material used for chimney construction, it can have distinct performance disadvantages when used to vent a controlled-combustion woodstove. Masonry forms an effective 'heat sink' - that is, it absorbs and holds heat for long periods of time. The large mass, however, may take a long time to become hot enough to sustain a strong draft. The larger the chimney (in total mass), the longer it will take to warm up. Cold masonry will actually cool exhaust gases enough to diminish draft strength. This problem is compounded if the chimney is located outside the home or if the chimney flue has a cross-sectional size larger than the stove outlet.

### Steel Chimney

Most factory-made 'Class A' steel chimneys have a layer of insulation around the inner flue. This insulation keeps the smoke warm and protects the surrounding structure from the high flue temperatures. Because the insulation is less dense than masonry, the inner steel liner warms up more quickly than a masonry chimney. Although steel chimneys are not as attractive as their masonry counterparts, they are very durable and generally outperform masonry.

### Inside/Outside Location

Because the chimney's function is to keep the smoke warm, it is best to locate it inside the house. This location uses the house as insulation for the flue and allows some radiant heat release from the flue into the home. Since an interior chimney does not continuously lose its heat to the outdoors, it takes less heat from the stove to get it warm and keep it warm.

### Flue Sizing

The flue size for a controlled-combustion appliance should be based on the cross-sectional volume of the stove flue outlet. In this case, more is definitely not better. Hot gases lose heat through expansion; if a stove with a six-inch flue collar (28 square inch area) is vented into a 10" x 10" flue, the gases will expand to over three times their original volume. As gases cool with expansion, draft strength decreases. If an oversized flue is also outside the house, the heat it absorbs will be conducted to the outdoor air and the flue will remain relatively cool.

It is common for a masonry flue to be oversized for the stove. Such a chimney can take quite a while to warm up and the stove performance will likely be disappointing. The best solution to an oversize flue problem is the installation of an insulated steel chimney liner of the same diameter as the appliance flue outlet. The liner keeps the exhaust gas warm and the result is a stronger draft. An uninsulated liner is a second choice - although the liner will keep the exhaust restricted to its original volume, the air around the liner will require time and heat energy to warm up.

Check your local codes. You may be required to install a flue liner in any oversize or masonry flue.

## Pipe & Chimney Layout

Every bend in the flue will act as a brake on the exhaust as it flows from the firebox to the chimney cap. The ideal pipe and chimney layout is straight up from the stove through a completely straight chimney. Use this layout if at all possible as it will promote optimum stove performance and simplify maintenance.

If the stovepipe must elbow to enter a chimney, locate the elbow about midway between the stove top and the chimney thimble. This configuration lets the smoke speed up before it must turn, keeps some pipe in the room for heat transfer, and allows long-term flexibility for installing a different appliance without relocating the thimble.

There should be no more than eight feet of single-wall stove pipe between the stove and a chimney. Longer runs can cool the smoke enough to cause draft and creosote problems. Use double-wall stove pipe for longer runs.

## Single Venting

Your stove requires a dedicated flue. Do not connect the stove to a flue used by any other appliance. Chimney draft is a natural form of energy and follows the path of least resistance. If the stove is vented to a flue that also serves an open fireplace or another appliance, the draft will also pull air in through those avenues. The additional air flow will lower flue temperatures, reduce draft strength and promote creosote development; overall stove performance will suffer. The effect is similar to that of a vacuum cleaner with a hole in the hose. In some extreme instances, the other appliance can even impose a negative draft and result in a dangerous draft reversal.

## Fuel

Even the best stove installation will not perform well if poor fuel is used. If available, always use hardwood that has been air-dried ('seasoned') 12-18 months. Softwood burns more rapidly than hardwood and has a high resin content conducive to creosote production. Decayed wood of any type has little heat value and should not be used.

All unseasoned ('green') wood has a high moisture content. Much of its heat value will be used to evaporate moisture before the wood can burn. This significantly reduces not only the amount of energy available to warm your home, but also the intensity of the fire and temperature of the exhaust gas. Incomplete combustion and cool flue temperatures promote creosote formation and weak draft.

You can judge the moisture content of wood by its appearance and weight or use a commercially available moisture meter for an exact measurement. Unseasoned wood will be a third heavier than dry wood. Also, look for cracks ('checking') in the ends of the log that result from contraction as the wood dries. The longer and wider the cracks, the dryer the wood is. Purchase your fuel from a reputable dealer.

## Creosote

Creosote is a by-product of low-temperature stove operations, weak draft or both. It is a tar that results when unburned gases condense inside the flue system at temperatures below 290°F. Creosote is volatile and can generate chimney fire. All of the installation characteristics that adversely affect chimney draft also promote creosote condensation. Consequently, you can minimize creosote accumulation with an effective chimney design and the use of operational techniques that encourage good draft and complete combustion.

## Backpuffing

Backpuffing is a condition that results when the draft is too weak to pull flue gases out of the chimney system as fast as the fire is generating more. Volatile gases build up within the firebox until reaching a density and temperature at which they ignite. With this ignition, you may hear a muffled popping sound and see a bit of smoke forced out of the air inlets.

This condition is most likely to occur in the spring or fall when moderate outdoor temperatures and low intensity fires combine to inhibit draft strength. If your stove backpuffs, open the damper to let the smoke rise to the flue more quickly. Also, open the air inlets to induce a livelier fire and speed airflow through the stove. Avoid large loads of firewood at one time. You should always see lively, dancing flames in the firebox; a lazy, smoky fire is inefficient and will promote draft problems.

## Draft Testing

An easy way to determine whether your chimney draft is strong enough is to close the stove damper, wait a few minutes to let the airflow stabilize, and then test whether you can vary the strength of the fire by swinging the air control open and closed. Results here are not always instant; you may need to wait a few minutes for a change in the air control setting to have an effect on the fire. If there is no change, the draft is not yet strong enough to let you close the damper. You will need to open it for awhile longer and manage the fire with the air inlet until the draft strengthens. Keep a record of your operational habits and relate them to their effects on the stove's function. You will be rewarded with safe and efficient performance.

### Negative Pressure

Good draft also depends on a sufficient supply of air to the stove. The chimney cannot pull more air than is available. Sluggish draft can be caused by a house that is tight enough to prevent the ready flow of air to the stove, or by competition between the stove and other appliances that vent indoor air to the outside; i.e., exhaust fans for range hoods, clothes dryers, bathroom, etc. If the chimney draws well when all such equipment is turned off (or sealed, in the case of the fireplaces and/or other stoves), you simply need to be attentive in timing the use of the other appliances. If you need to crack a nearby window or door to enable the chimney to pull well, you should install an outside-air intake to bring combustion air directly to the stove. Consult your Vermont Castings' dealer regarding an adapter to attach to the stove to connect an air duct for outdoor combustion air.

### Conclusion

Woodburning is more an art than a science. Art includes technique and since installations, homes and fuel vary, the stove operator must also vary technique, (mostly timing), to achieve satisfying results. Over time, you will become familiar with the intricacies and nuances of your particular installation and you will be able to identify cause and effect in a variety of seasonal circumstances.

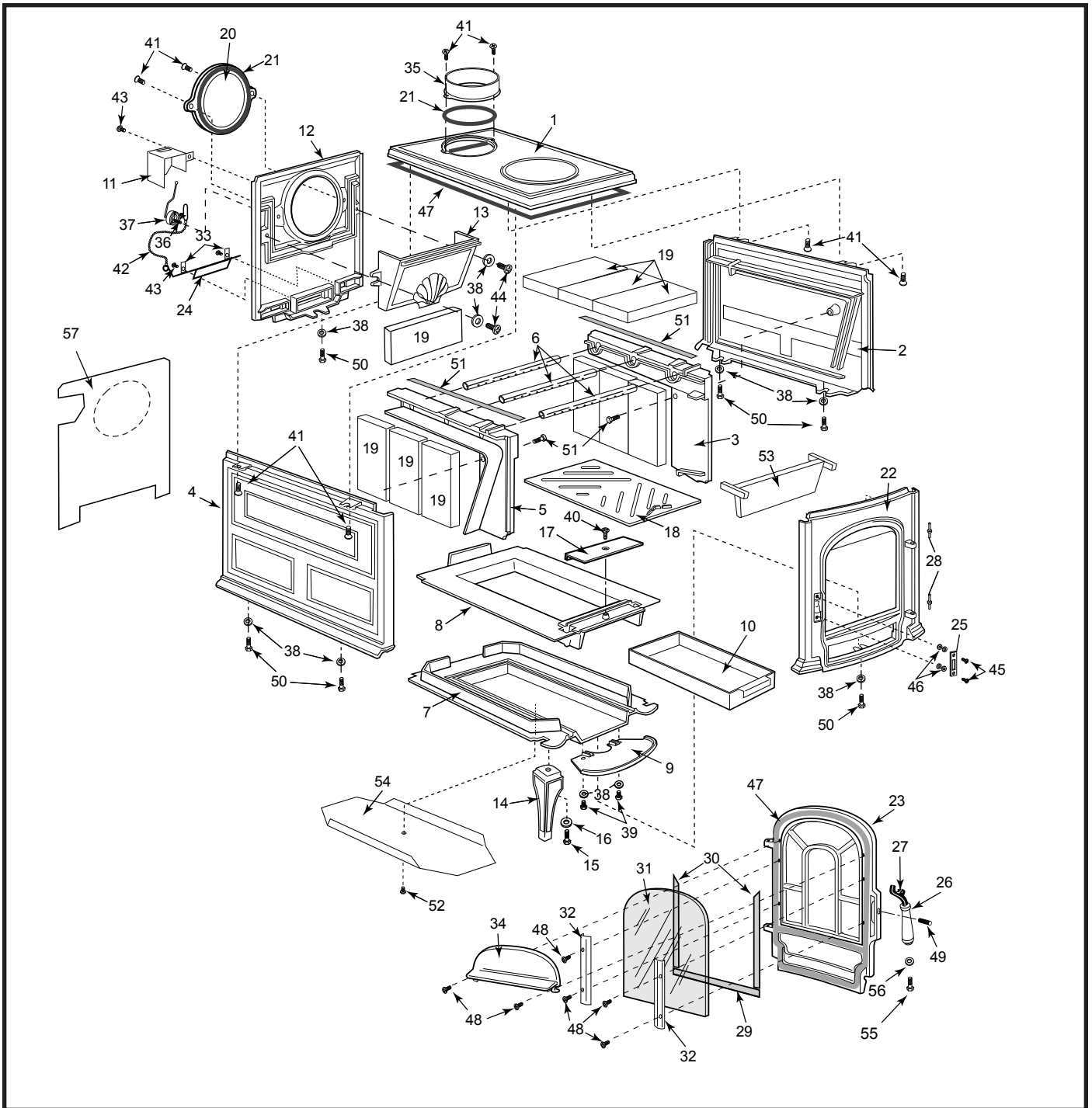

MHSC reserves the right to make changes in design, materials, specifications, prices and discontinue colors and products at any time, without notice.

# Aspen Woodburning Stove

## Model 1920

**Aspen Woodburning Stove Model 1920 (continued)**

Item Description	Part Number
1. Top	See Chart Pg. 28
2. Right Side	See Chart Pg. 28
3. Secondary Air Channel, Right	30000606
4. Left Side	See Chart Pg. 28
5. Secondary Air Channel, Left	30000607
6. Secondary Air Tube	30000368
7. Bottom	30000343
8. Bottom, Inner	30000346
9. Ashlip	See Chart Pg. 28
10. Ashpan	30000363
11. Thermostat Cover	30000371
12. Back	30000347
13. Fireback	30000358
14. Leg (4)	See Chart Pg. 28
15. Leg Bolt, 3/8"-16x1" hex bolt (4)	1201432
16. 3/8" Flat Washer (4)	1202488
17. Primary Air Plate	30000356
18. Grate, Wood	30000604
19. Firebrick (10)	1601103
20. Flue Cover	See Chart Pg. 28
21. 5/16" Adhesive Gasket	1203591
22. Front	See Chart Pg. 28
23. Door	See Chart Pg. 28
24. Primary Air Flap	30000370
25. Door Handle Catch	30000365
26. Wooden Handle	30000366
27. Door Handle Shaft	30000364
28. Door Pin, Long	1600416

Item Description	Part Number
29. Glass Gasket, horizontal (8¼")	30000382
30. Glass Gasket, vertical (2)	30000383
31. Glass Panel	30000362
32. Glass Retainer (2)	30000474
33. Glass Clips (2)	1601394.
34. Door Manifold	30000357
35. Flue Collar	See Chart Pg. 28
36. Friction Spring	1201846
37. Primary Thermostat Assembly	30000503
38. 1/4" Flat Washer, Zinc (10)	1202474
39. 1/4-20x5/8" Hex Screw (2)	1201372
40. 1/4-20x1¼" Flt Hd Phillips Screw	1200811
41. 1/4-20x3/4" Flat Hd Phillip Screw (6)	1200881
42. Ball Chain, Thermostat	1201960
43. 10-20x1/4" Plain Truss Head Screw (5)	1200996
44. 1/4-20x5/8" Round Hd Phillips Screw (2)	1200896
45. 1/4-20x3/8" Round Hd Philips Screw (2)	1200894
46. 1/4 Flat Washer (4)	1202475
47. 7/16" Round Gasket (9.3ft.)	7000910
48. 10-24x3/8" Round Hd Slotted Screw (6)	1200983
49. 3/16"x1" Roll Pin	1201833
50. 1/4-20x1" Hex Head Screw (8)	1201326
51. Gasket, Flat w/adhesive (3 ft.)	30000504
52. 1/4-20x3/8" Pan Hd Phillips Screw	1201053
53. Deflector Rib	30000597
54. Bottom Heat Shield	30000384
55. Handle, Screw Pan head Phillips	1200986
56. Washer, Flat #10 .218 id x .5 od	1202423
57. Rear Heat Shield	30000385
58. Spacer HS 1 25 NI (not shown)	1601755

**Shell Enamel Parts - Aspen**

Part Name	Classic	Ebony	Forest Green	Suede Brown	Vermont Classic Green	Bordeaux
Top III	30001654	30001660	30001661	30002588	30003167	30004007
Left Side II	30001656	30001664	30001665	30002591	30003170	30004010
Right Side II	30001655	30001662	30001663	30002590	30003169	30004009
Flue Collar	30000353	30000483	30000492	30002589	30003168	30004008
Flue Cover	30000351	30000481	30000490	30002585	30003164	30004004
Front	30000348	30000478	30000487	30002586	30003165	30004005
Ashlip	30000352	30000482	30000491	30002593	30003172	30004012
Door	30000350	30000480	30000489	30002587	30003166	30004006
Leg Set of Four	30000502	30000539	30000540	30002594	30003173	30004013
Single Leg	30000360	30000484	30000493	30002592	30003171	30004011







# Warranty

## Limited 3 Year Warranty

MHSC warrants that this woodburning stove will be free of defects in material and workmanship for a period of three years from the date you receive it, except that the catalyst, thermostat assembly, handles, glass door panels, cement, and gasketing shall be warranted as described below.

Products will repair or replace, at its option, any part found to be defective upon inspection by a MHSC Authorized Dealer. The customer must return the defective part or the stove, with shipping prepaid, to the Authorized Dealer or pay for any Authorized Dealer in-home travel fees or service charges for in-home repair work. It is the dealer's option whether the repair work will be done in the customer's home or in the dealer's shop. If, upon inspection, the damage is found to be the fault of the manufacturer, repairs will be authorized at no charge to the customer for parts and/or labor.

Any woodburning stove or part thereof that is repaired or replaced during the limited warranty period will be warranted under the terms of the limited warranty for a period not to exceed the remaining term of the original limited warranty or six (6) months, whichever is longer.

## Limited 1 Year Warranty

The following parts of the woodburning stove are warranted to be free of defects in material and workmanship for a period of one year from the date you receive it: The thermostat assembly, handles, glass door panels, cement, and gasketing. Any of these items found to be defective will be repaired or replaced at no charge, upon the return of the part with postage prepaid to a MHSC Authorized Dealer.

Any part repaired or replaced during the limited warranty period will be warranted under the terms of the limited warranty for a period not to exceed the remaining term of the original limited warranty or six (6) months, whichever is longer.

## Exclusions & Limitations

1. This warranty is transferable; however, proof of original retail purchase is required.
2. This warranty does not cover misuse of the this stove. Misuse includes overfiring which will result if the stove is used in such a manner as to cause one or more of the plates to glow red. Overfiring can be identified later by warped plates and areas where the paint pigment has burned off. Overfiring in enamel fireplaces is identified by bubbling, cracking, chipping and discoloration of the porcelain enamel finish. MHSC offers no warranty on chipping of enamel surfaces. Inspect your woodburning stove prior to accepting it for any damage to the enamel.
3. This warranty does not cover misuse of the stove as described in the Owner's Guide, nor does it cover any stove which has been modified unless authorized by a MHSC representative in writing. This warranty does not cover damage to the stove caused by burning salt saturated wood, chemically treated wood, or any fuel not recommended in the Owner's Guide.

4. This warranty does not cover a stove repaired by someone other than a MHSC Authorized Dealer.
5. Damage to the unit while in transit is not covered by this warranty but is subject to a claim against the common carrier. Contact MHSC Authorized Dealer from whom you purchased your stove or MHSC if the purchase was direct. (Do not operate the stove as this may negate the ability to process the claim with the carrier.)
6. Claims are not valid where the installation does not conform to local building and fire codes or, in their absence, to the recommendations in our Owner's Guide.
7. The salt air environment of coastal areas, or a high-humidity environment, can be corrosive to the porcelain enamel finish. These conditions can cause rusting of the cast iron beneath the porcelain enamel finish, which will cause the porcelain enamel finish to flake off. This warranty does not cover damage caused by a salt air or high-humidity environment.
8. MHSC shall have no obligation to enhance or update any unit once manufactured.

IN NO EVENT SHALL MHSC BE LIABLE FOR INCIDENTAL AND CONSEQUENTIAL DAMAGES. ALL IMPLIED WARRANTIES, INCLUDING THE IMPLIED WARRANTIES OF MERCHANTABILITY AND FITNESS, ARE LIMITED TO THE DURATION OF THIS WRITTEN WARRANTY. THIS WARRANTY SUPERCEDES ALL OTHER ORAL OR WRITTEN WARRANTIES.

Some states do not allow the exclusion or limitations of incidental and consequential damages or limitations on how long an implied warranty lasts, so the above limitations may not apply to you. This warranty gives you specific rights and you may have other rights which vary from state to state.

## How to Obtain Service

If a defect is noted within the warranty period, the customer should contact a MHSC Authorized Dealer or MHSC if the purchase was direct with the following information:

1. Name, address, and telephone number of the purchaser.
2. Date of purchase.
3. Serial number from the label on the back.
4. Nature of the defect or damage.
5. Any relevant information or circumstances, e.g., installation, mode of operation when defect was noted.

A warranty claim will then start in process. MHSC reserves the right to withhold final approval of a warranty claim pending a visual inspection of the defect by authorized representatives.

**MHSC**

---

149 Cleveland Drive • Paris, Kentucky 40361  
[www.mhsc.com](http://www.mhsc.com)