

Installation/Operator's Manual

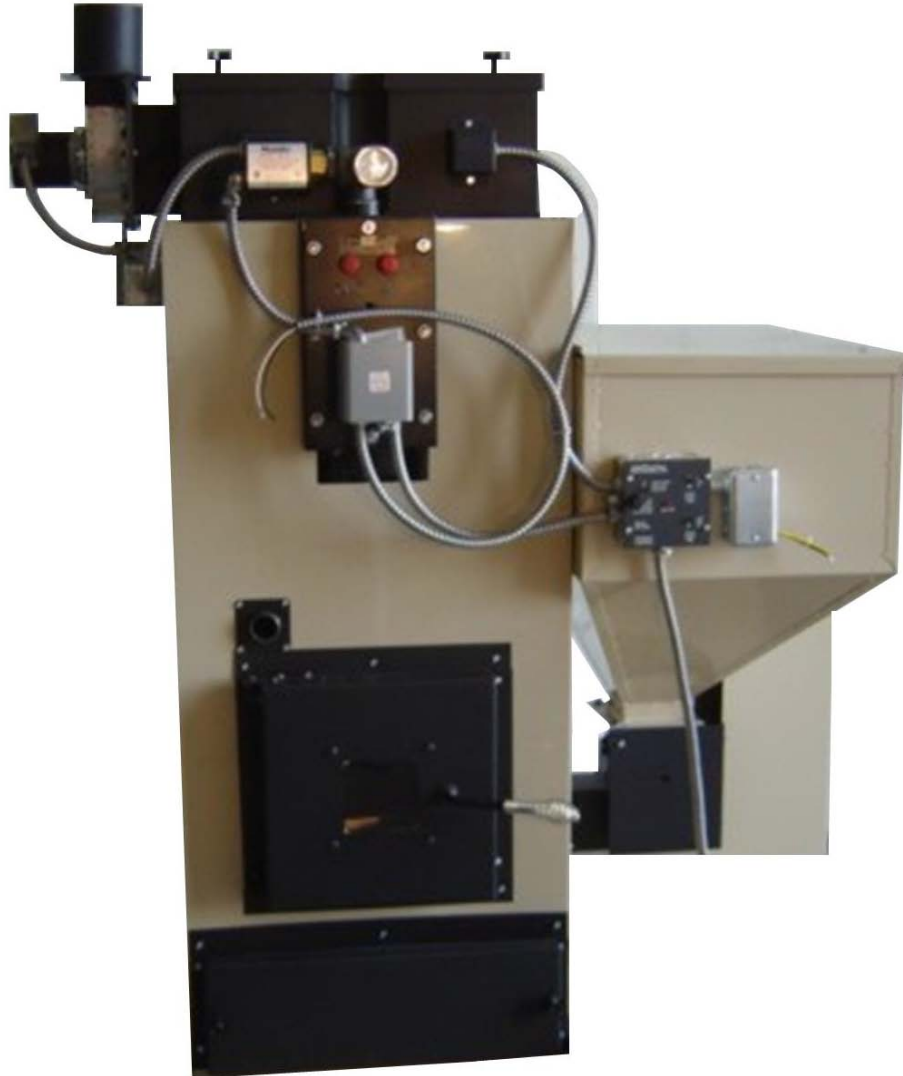

SAFETY NOTICE

Please read entire manual before installation and use of this pellet fuel-burning boiler. Failure to follow these instructions could result in property damage, bodily injury or even death. Contact local building or fire officials about restrictions and installation inspection requirements in your area.

SAVE THESE INSTRUCTIONS



PINNACLE PB150 PELLET/CORN BOILER

PINNACLE STOVE SALES INC
1089 HIGHWAY 97 NORTH
QUESNEL, BC V2J 7C9
TEL. (250) 992-5050
FAX. (250) 992-5850

BOILER SPECIFICATIONS

BTU INPUT ----- 85,000 TO 130,000 BTU/HR

EFFICIENCY (HEAT TRANSFER) ----- 80%

HEIGHT ----- 62"

WIDTH OVERALL ----- 47"

DEPTH ----- 29"

HOPPER CAPACITY ----- 160 lbs

WEIGHT ----- 585 lbs

FLUE SIZE ----- 4"

BREACH ----- LEFT SIDE

DOMESTIC HOT WATER COIL (GPM) ----- 5 gal
(5 GPM. 40°F to 140°F boiler water temperature at 200°F)

WATER CONTENT (GALLON) ----- 16 gal

SUPPLY TAPPING ----- 1-1/4"

RETURN TAPPING ----- 1-1/4"

RELIEF VALUE TAPPING ----- 3/4"

SPECIFICATIONS

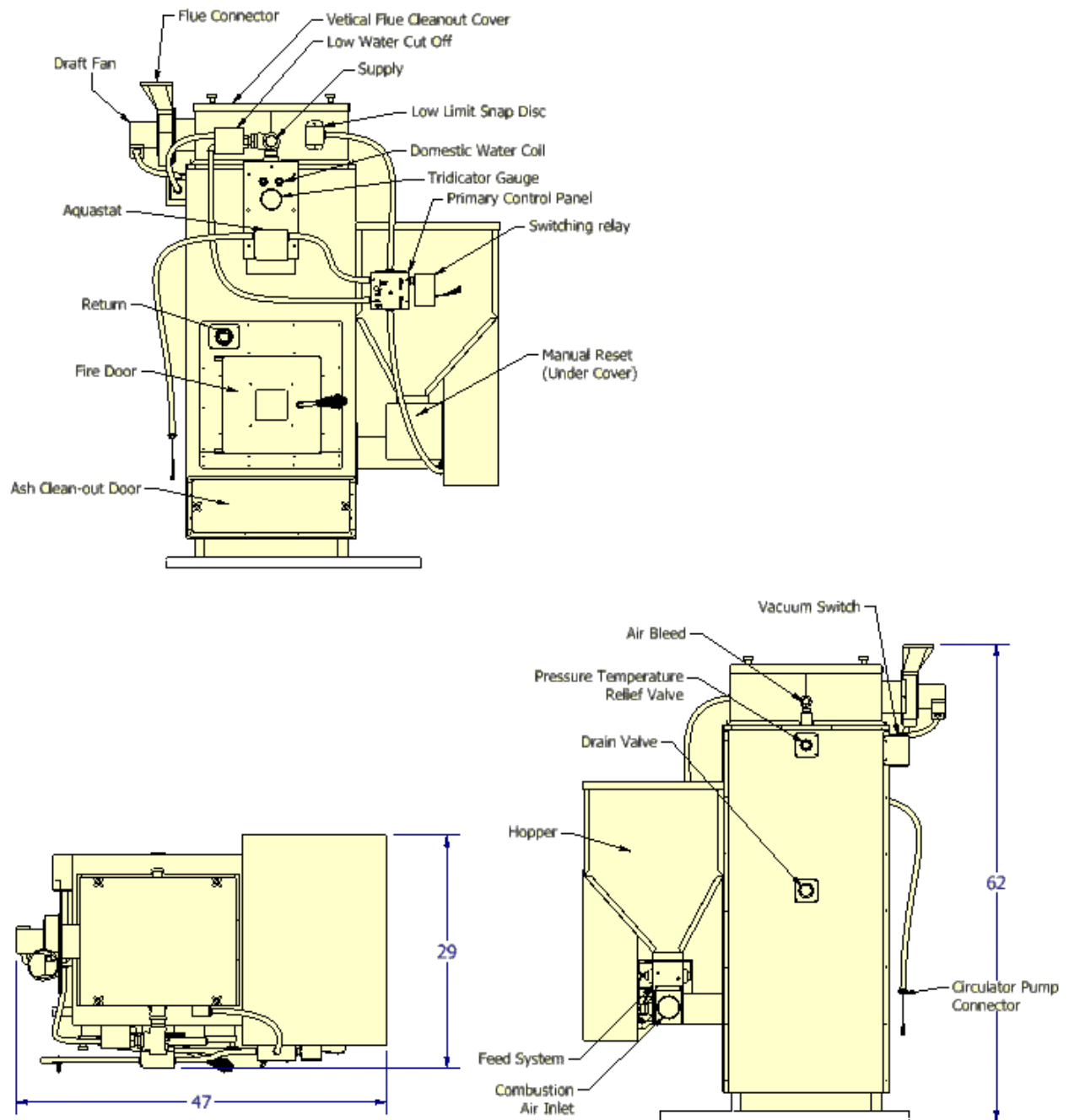

Figure 1

INSTALLATION

GENERAL

The PB150 hot water steel boilers are high quality pellet/corn fired heating units. The installation of the unit shall be in accordance with the regulations of the authorities having jurisdiction.

FREIGHT CLAIMS

All units should be inspected for damage upon arrival. Concealed damage claims should, be filed immediately against the carrier by the consignee. The carrier is responsible for taking prompt action on all claims.

SIZING

A complete heat loss calculation of the structure is necessary to choose the proper size unit to install. The boiler should be sized to within 25% of the actual calculated heat loss of the structure. Over sizing will result in short cycling and inefficient operation. The PB150 boilers have large water content allowing for ample domestic hot water.

Replacement boiler should not be sized from the firing rate of the old boiler. A DOE sponsored study indicates 65% of the heating units in U.S. homes are substantially oversized.

BOILER LOCATION

Boiler to be installed on a **non-combustible heat resistant surface** in a liquid containment pan attached to a drain in a level position with clearances in accordance with NFPA 31 Table 4-1 Form IL

STANDARD CLEARANCES

Front	24"	610mm
Sides	6"	152mm
Rear	6"	152mm
Chimney Connector	18"	460mm

Reduced clearance installations shall comply with NFPA 31 Table 4-2 Appendix B.

To move the unit, push against the flue box or skids. Pushing or pulling the jacket or burner will result in damage.

Be sure to level the unit by inserting shims under the base.

AIR FOR COMBUSTION AND VENTILATION

The unit must be installed where provision exists for combustion and ventilation air. Ordinarily, provisions may be furnished by the following methods:

UTILITY ROOM

In buildings of tight construction, including most modern homes, you should provide an opening, connecting to a well-ventilated attic, crawl space or directly with the outdoors. The opening should have a minimum free area of 1 square inch per 1,000 BTU per hour of total input for all appliances in the enclosure and should terminate below the burner level. Boilers installed in confined areas must have two ventilation

openings in the door. Each opening should have a free area of not less than 1 square inch per 1,000 BTU (140 square inch per US GPH) of the total input for all appliances in the enclosure. One opening located, near top of enclosure and one near the bottom.

BASEMENT

Where a boiler is installed in a full basement, infiltration is normally adequate to provide air for combustion.

In buildings of tight construction where the basement windows are weather stripped, one opening communicating with a well-ventilated attic or with the outdoors should be provided. The opening should have a minimum free area of 1 square inch per 1,000 BTU per hour of total input for all appliances in the enclosure.

SPECIAL CONDITIONS

Where a boiler is located in an area where the operation of exhaust fans, kitchen ventilation systems, clothes dryers, or fireplaces may create conditions of unsatisfactory combustion or venting, special provisions should be made for additional air for combustion, as specified by local authority.

TRIM ASSEMBLY

Install the drain valve in the 1- $\frac{1}{4}$ " tapping on the backside of the boiler. Install the safety relief valve in the $\frac{3}{4}$ " tapping on the backside of the boiler. The safety relief valve should be piped to a place of safe discharge. Install your air bleed connection into the 90° elbow mounted in the top $\frac{3}{4}$ " tapping behind the smoke collector box. Install the altitude gauge in the $\frac{1}{4}$ " tapping provided on the front in the coil plate.

PACKAGED BOILER

Controls and burner are installed and pre-wired at the factory. Install Relief Valve as noted in Trim Assembly.

BOILER PIPING

Minimum supply and return pipe size of not less than 1 $\frac{1}{4}$ " to be used.

The recommended locations of pumps, expansion tanks, etc. are illustrated in Figures 2, 3, & 4. Relief valve discharge and drain valve piping should be piped to a safe place of discharge. ALL plugs and water connections should be checked for leaks upon installation and annually.

TANK-LESS WATER HEATING PIPING

The tank-less heater may be connected as shown in Figure 4. A mixing valve (not supplied) may be used to reduce the water temperature at kitchen or bathroom taps. When connecting to the domestic water coil a pressure temperature relief valve must be installed.

High temperature water for a dishwasher may be obtained by piping as shown.

THE NUTS THAT SECURE THE TANKLESS COIL FLANGE SHOULD BE TIGHTENED BEFORE THE BOILER IS FILLED WITH WATER, AFTER INITIAL FIRING AND EVERY YEAR DURING ANNUAL MAINTENANCE. DETERIORATION DUE TO COIL GASKET LEAKS SHALL VOID WARRANTY.

BURNER AND CONTROLS

Honeywell L6081A Aquastat Controller

This control is installed on the middle fitting of the domestic coil. These immersion type controls are used with forced hydronic heating systems, which include domestic water service. This model provides high limits, low limits for maintaining minimum boiler water temperature and circulator controls. See the wiring diagram for proper connections of this unit. The primary control is factory wired to the aquastat controller. These controls working as a system will prevent the circulator operation if the water temperature is below a predetermined low level. Likewise, if the water level reaches a predetermined high limit the burner will automatically shut off.

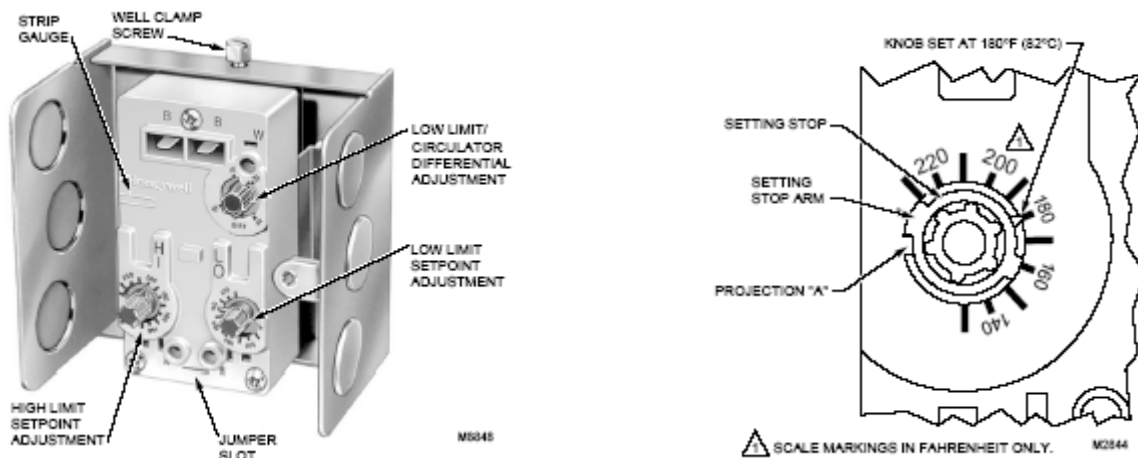

Low Water Cut-off Switch RB-122

This control is installed in the supply tapping in the top front of the boiler. The RB-122 low water control is specifically designed to provide burner cut-off if there is an unsafe water loss, which can result from a broken or leaking radiator or pipe, or a cracked section in the boiler.

SEQUENCE OF OPERATION

Forced Circulation Hot Water System with Tank-less Heater

When the room temperature falls below thermostat setting, thermostat calls for heat switching the control to full burn mode. When water temperature rises to the preset temperature setting on the low limit – circulator control the circulator pump is turned on providing hot water to room zone. At the same time the relay trips and reduces the burner to pilot mode preventing over temperature. If the circulator pump turns off because of low water temperature before the room thermostat is satisfied the relay energizes and switches the burner back to full burn mode to increase the water temperature. This cycling will continue until the room thermostat is satisfied. When the room thermostat is satisfied the burner will switch back into pilot mode waiting for the next heat demand. Because the burner stays in pilot mode between calls for heat, in extended low demand periods the water temperature may rise enough to turn the circulator pump on therefore a dump zone should be configured into the system.

PRIMARY CONTROL 011350S SEQUENCE OF OPERATION

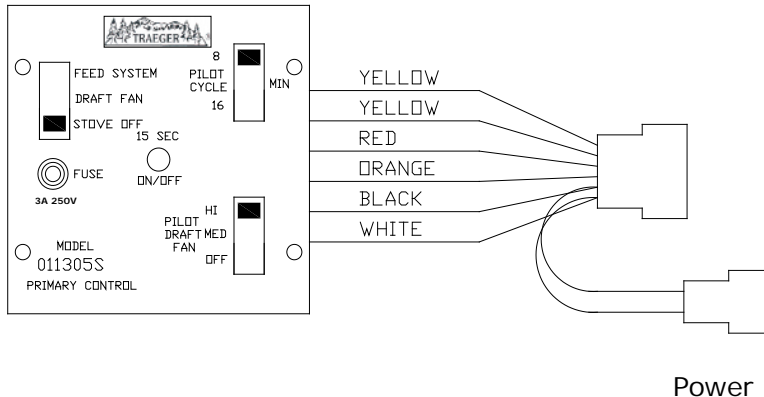

The Traeger 011350S primary control is a high-tech, state of the art computer. The control performs the function of piloting the system when the thermostat does not call for heat. It conserves fuel consumption.

FUSE

The computer board is protected by an AGC 3-amp fuse. There are many manufacturers of this fuse. Fuses are readily available at your local hardware or auto parts store.

RED LIGHT INDICATOR 15 SECOND ON/OFF

When the wall thermostat circuit is closed, and calling for heat, the light indicator will remain dim as long as the circuit is closed. When the thermostat is open (not calling for heat) the light will blink from bright to dim every 15 seconds as part of the counting procedure.

ON TIME (2MINUTES)

The On Time controls the amount of time the burner stays active (fuel is fed). It operates in conjunction with the cycle time and is pre-set in the control at 2 minutes

PILOT CYCLE TIME SWITCH

The PILOT CYCLE time switch controls the total cycle both on and off, 8 or 16 minutes.

COMBINATION FUNCTION OF ON TIME AND CYCLE TIME

The On Time is subtracted by the Cycle Time Example: With the On Time pre-set at 2 minutes and the Cycle Time set at 16 minutes, the unit would come on (feed corn) for 2 minutes and not feed corn for 14 minutes. This gives you a complete cycle time of 16 minutes.

WIRING

The 011350S primary control has 6 lead wires. A wiring colour code is provided on back of each control. Black is line power. White is neutral. Red is load and feeds the auger motor and cup motor. Orange feeds the draft inducer. 2 yellows go to the wall thermostat.

POWER SWITCH

The POWER switch cuts power to burner but not blower fan system and to shut the furnace down.

PILOT DRAFT SWITCH

The PILOT DRAFT switch controls the speed of the draft inducer on pilot or idle mode. Normally set on Medium, but will vary with differing chimney configurations.

FUNCTIONING OF SAFETY AND OPERATING CONTROLS

The safety and operating controls shall function within the limits specified by the manufacturer for the type of equipment. The following tests shall be performed:

- (a) Check the operation of the automatic fuel feeding interrupt device at each entrance to the floor space within which the fuel-feeding device is installed.
- (b) Check that when the low water level control on steam and hot water boilers is operated to indicate a low water level, the automatic fuel-feed is interrupted.
- (c) Check that when the excessive pressure control on steam and hot water boilers is operated as in an excessive pressure situation, the automatic fuel-feed is interrupted.
- (d) Check that when the excessive water temperature control on hot water boilers is operated to indicate excessive water temperature, the automatic fuel-feed is interrupted and, if appropriate, that one or more zone control valves open.
- (e) Check that if the temperature exceeds 95°C (200°F) in a furnace supply plenum on hot air furnaces, the automatic fuel-feed is interrupted.
- (f) Check that if there is a failure of the fan providing combustion air, the automatic fuel-feed is interrupted.
- (g) Check that if there is a failure of the combustion air supply control mechanism to remain fully open, the automatic fuel-feed is interrupted.
- (h) Check that when the hot water circulating pump manual disconnect switch, is opened, the automatic fuel-feed is interrupted.
- (i) Check that if there is a shutdown or failure of the mechanical flue-gas exhauster, the automatic fuel-feed is interrupted.
- (j) Check that if there is a failure in the flue gas flow, the automatic fuel-feed is interrupted, or the combustion air supply is shut off in manually fuel appliances.
- (k) Check for the proper operation of the minimum fire maintenance controls and system or, if applicable, of the automatic ignition system.
- (l) Check for the proper operation of the controls used for normal automatic fuel feeding.
- (m) Check the operation of any other controls supplied on the appliance by the manufacturer, or required by the authority having jurisdiction.

VENTING

Chimney required for the PB150 is 4" Class "L" (also known as PL vent). A starting collar must be used to attach the venting system to the furnace. When connecting into a Class "A" or masonry chimney a listed 4" liner MUST be used to prevent back drafting of the chimney.

EXISTING CLASS "A" CHIMNEY:

Run 4" Class "PL" connector from the furnace connection to a positive connection with the class "A" chimney. **A LISTED 4" STAINLESS STEEL LINER MUST BE USED IN CLASS "A" CHIMNEYS.** Make sure each joint is firmly locked into place. Make sure the attachment of Class "PL" to the Class "A" chimney is secure with sheet metal screws. Seal all joints with high temperature silicone. Class "PL" connector should maintain a pitch on rise from the furnace to the chimney of at least 1/4" per foot.

- A.) "PL" Vent connector 4" B.) "PL" Vent elbow 90° adj. 4"

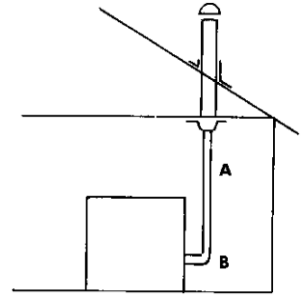

EXISTING MASONRY CHIMNEY: Run 4" Class "PL" connector from the furnace connection to a positive connection with the masonry chimney. Make sure each joint is firmly locked in place. Make sure the penetration of the Class "PL" connector into the masonry chimney is sound and secured with high temperature cement. Seal all joints with high temperature silicone. Class "PL" connector should maintain a pitch on rise from the furnace to the chimney of at least 1/4" per foot.

A LISTED 4" STAINLESS STEEL LINER MUST BE USED IN MASONRY CHIMNEYS. Your new furnace is so efficient; an unlined chimney could remain cold and cause a downward pressure creating poor burning, incomplete combustion or back draft.

- A.) "PL" Vent connector 4" B.) "PL" Vent elbow 90° adj. 4"

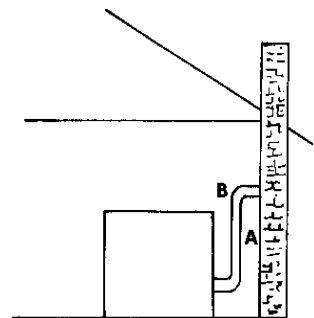

NEW VERTICAL INSTALLATIONS: Install 4" Class "PL" chimney and accessories according to manufacturers instructions and local codes (3" clearance to combustibles). Run Class "PL" chimney all the way from the furnace connection to point of termination. Make sure each joint is firmly locked in place. Seal all joints with high temperature silicone. Class "PL" connector should maintain a pitch on rise from the furnace to the chimney of at least 1/4" per foot.

- A.) Vertical top 4" D.) Adj. flashing 4"
 B.) "PL" Vent pipe 4" E.) Fire stop spacer 4"
 C.) Storm Collar 4" F.) "PL" Vent 90° adj. 4" clean out tee

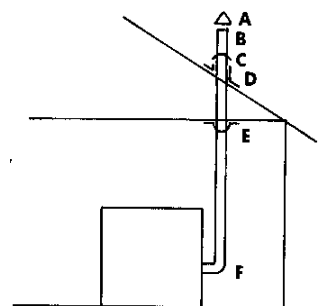

Horizontal runs should be kept as short as possible while maintaining sufficient draft to operate the appliance properly.

Pinnacle Stove Sales provides no warranty or assumes any responsibility for smoke damage caused by reverse drafting of any pellet appliance under power failure conditions.

VENTING

GENERAL- A PELLETT/CORN FIRED UNIT SHALL BE CONNECTED TO A FLUE HAVING SUFFICIENT DRAFT AT ALL TIMES TO ASSURE PROPER OPERATION.

1. Only a trained experienced serviceman should attempt the installation or service of any boiler and or venting device. All venting installations must comply with the recommendations of the venting manufacturer and with all state and local codes. Only use listed PL type venting with an inside diameter of 4 inches. Warning, used chimney venting must be clean and in good condition.
2. All joints must be securely locked together, caulked with high temperature silicone and fastened with at least 3 screws. This will prevent leakage and future disassembly.
3. PL Vent must be supported from the structure by means of metal or other non-combustible supports; horizontal pipes shall be supported at intervals not exceeding 3 ft (1 m), exterior vertical pipes shall be supported at intervals not exceeding 6ft (2 m).
4. **DO NOT INSTALL A FLUE DAMPER IN THE EXHAUST VENTING SYSTEM OF THIS UNIT; and DO NOT CONNECT THIS UNIT TO A CHIMNEY FLUE SERVING ANOTHER APPLIANCE.**

BOILER DAMPER CONTROLS

Damper operation

The damper is a plate that helps control the amount of airflow supplied for proper combustion. With the damper pushed all the way in the airflow is at its minimum. As the damper is pulled out, more air is allowed to flow.

It will be necessary to monitor the appearance of the flame during the first 4-8 bags of fuel. If your flame is smoky red/orange with evidence of soot at the top of the flame, you need more combustion air, pull the damper out ¼ inch and re-evaluate the appearance of the flame. It may be necessary to repeat this process, moving the damper ¼ inch at a time until proper combustion is attained (the flame should become yellow and begin to "dance"). Tighten the damper lock down bolt and monitor flame to maintain proper combustion.

Symptoms of insufficient combustion air include unburned fuel, lazy smoky or red/orange flame, excessive ash or soot, excessive build-up on glass.

Symptom of excessive combustion air include fuel burns to quickly (smoking or smouldering pellets), white to yellow flame.

WARNING ABOUT CHIMNEY FIRES

Failing to maintain your woodstove or fireplace properly can lead to a chimney fire. Chimney fires occur when combustible deposits on the inner walls of the chimney ignite. These combustible deposits, called "creosote," are a natural by-product of wood burning. A fire hazard exists if ¼" of creosote (or more) coats the inner walls of the chimney.

Prevention: Chimney fires do not occur in clean, intact, properly installed chimneys. Have a professional chimney sweep clean and inspect your appliance at least once a year. More frequent cleanings may be required, based on the type of wood burned, the type of appliance, and the frequency of use. In general, an older, uncertified woodstove, or any appliance that is used frequently, will require more than one cleaning per year.

Detection: The first indication of a chimney fire is usually the noise—a roaring sound that grows louder as the fire's intensity increases. Clouds of black smoke and sparks will be seen exiting the top of the chimney; in severe fires, flames can extend several feet above the chimney.

Action: In case of a chimney fire, follow these steps:

1. Call the fire department immediately.
2. Alert others in the house to evacuate.
3. Close the appliance's dampers and/or the primary air inlet controls, limiting the fire's air supply and reducing its intensity.
4. Open the appliance door just enough to insert the nozzle of a 10 lb. dry chemical fire extinguisher rated for Class ABC fires. Discharge the entire content of the extinguisher into the appliance and shut the door.
5. If possible, wet down the roof and other outside combustibles to prevent fires ignited by shooting sparks and flames.
6. Closely monitor all combustible surfaces near the chimney. During severe chimney fires, these surfaces can become hot enough to ignite.

After a chimney fire, have the chimney inspected by a professional chimney sweep or woodstove/fireplace installer; choose a professional who has earned credentials from the National Chimney Sweep Guild at www.ncsg.org, Chimney Safety Institute at www.csia.org or the Hearth Education Foundation at www.hearthed.com. Contact your insurance carrier.

DO NOT USE THE CHIMNEY UNTIL A PROFESSIONAL HAS INSPECTED IT.

The excessive heat produced by a chimney fire can crack chimney walls, damage chimney liners, and damage some types of factory-built chimneys. If not repaired, these damages create a greater possibility for any subsequent chimney fire to spread beyond the confines of the flue to the house.

DOMESTIC WATER SYSTEM

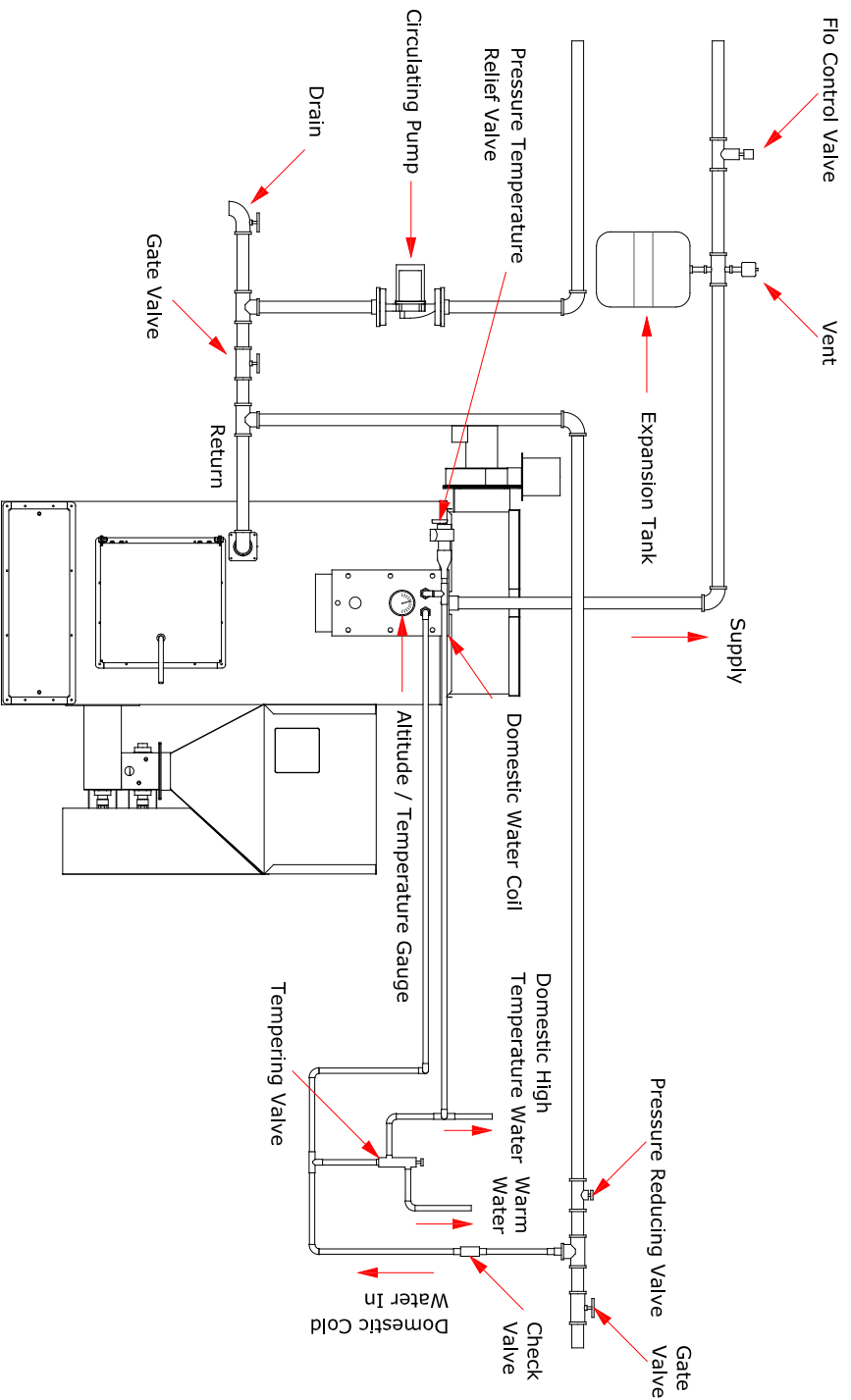

Install Relief Valve in the top tapping on rear of boiler. Relief valve discharge and drain valve piping should be piped to a safe place of discharge.

Figure 3

DOMESTIC WATER COIL CONNECTION

When installing the domestic water coil connection an **ASME certified pressure / temperature relief valve must be installed**. Install pressure temperature relief valve in the hot water supply side exiting the domestic water coil, see figure 5. Drain valve piping should be piped to a safe area for discharge. Failure to install pressure temperature relief value will void boiler warranty.

Pressure Temperature Relief Valve Installation

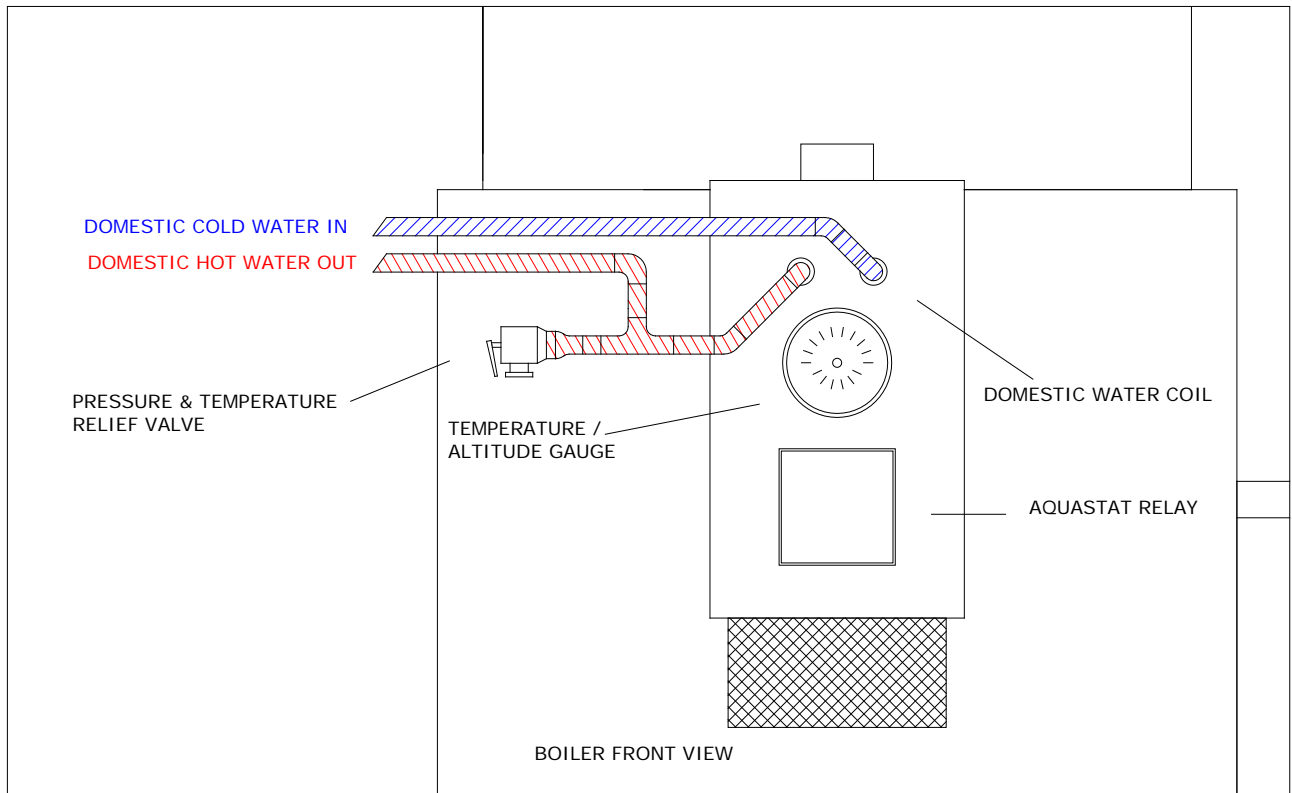
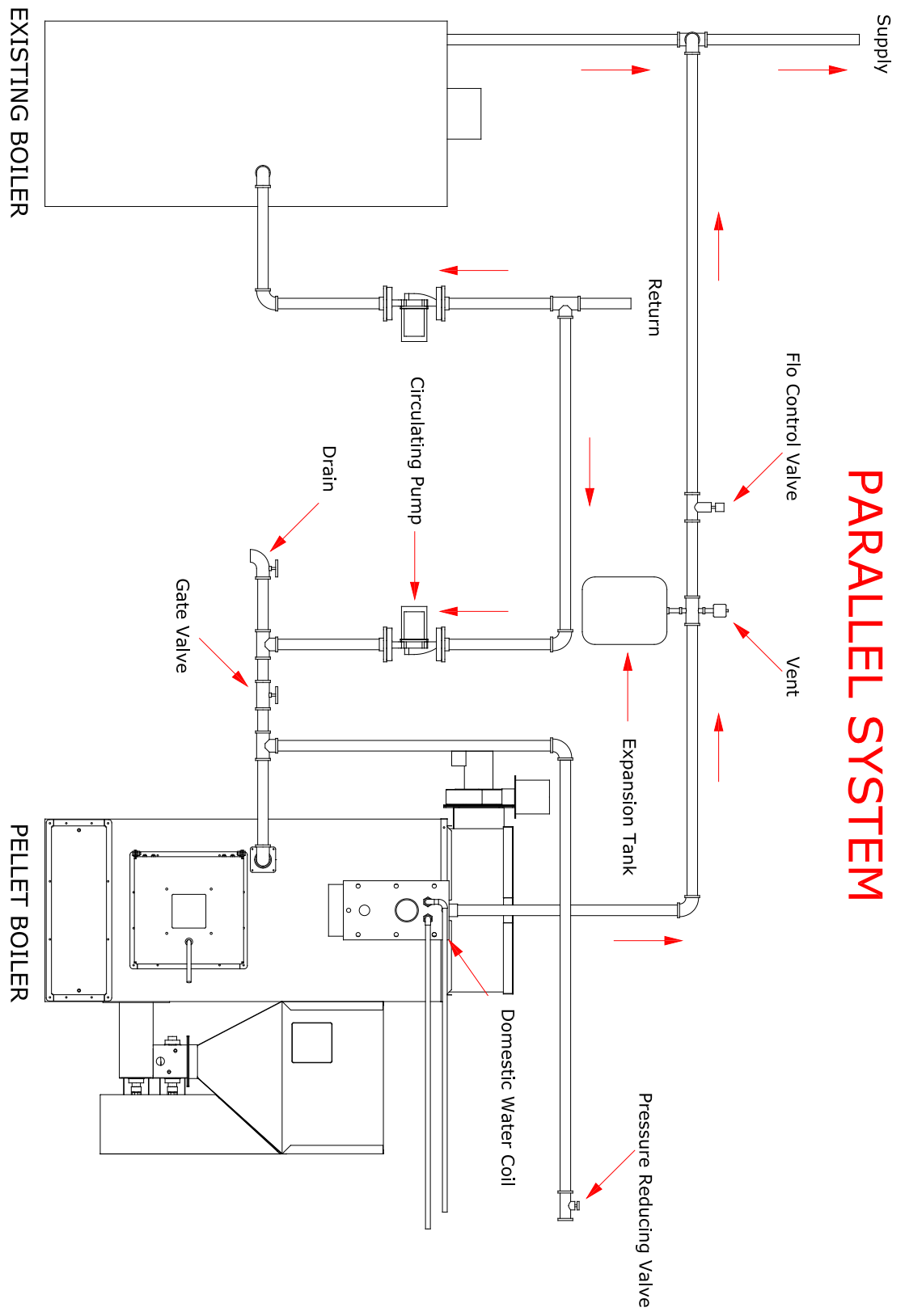

Figure 4

PARALLEL SYSTEM



Install Relief Valve in the top tapping on rear of boiler. Relief valve discharge and drain valve piping should be piped to a safe place of discharge.

Figure 5

SERIES SYSTEM

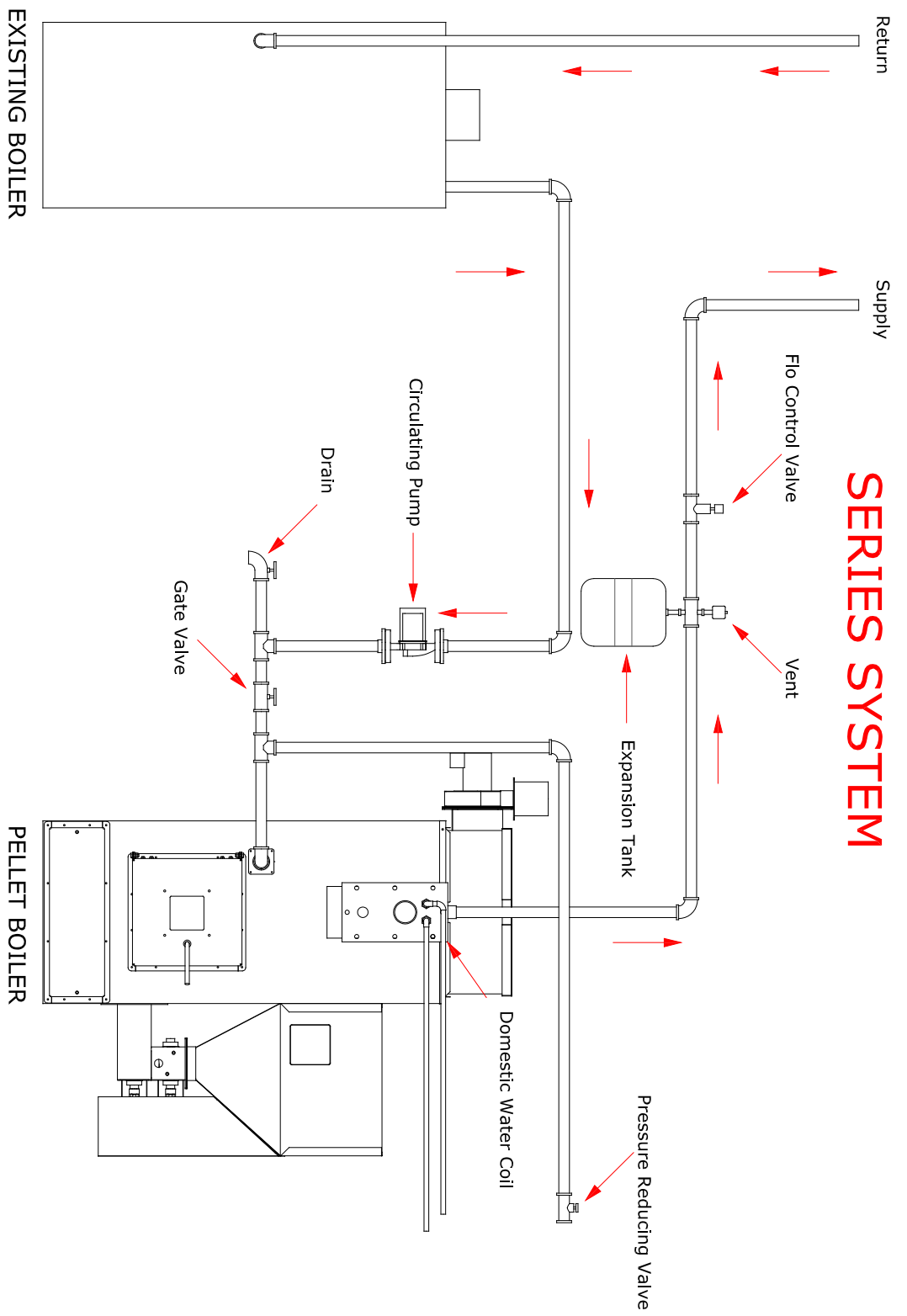

Install Relief Valve in the top tapping on rear of boiler. Relief valve discharge and drain valve piping should be piped to a safe place of discharge.

Figure 6

WIRING INFORMATION

All internal electrical wiring is completed at the factory. All external wiring must conform to the National Electric Code and any local codes. Line voltage leads utilize wire nut connections.

**A surge suppressor should be installed to protect control board.
Surge suppressors are available now that mount to your breaker box providing protection to your whole house.**

Refer to the wiring diagrams for all field wiring.

- A. Field connections should be protected with a 15-amp fuse.
- B. Install the room thermostat on an inside wall away from cold drafts, windows, or heat from fireplaces, appliances, or sunlight. Set the heat anticipator at .1 amps. Connect the thermostat leads to the yellow wires on control board.
- C. Install a separate fused disconnect switch near the unit so power can be shut off for servicing.
- D. Shut off service switch when the boiler is not in use for extended periods.
- E. **Failure to provide surge protection will void control board warranty.**

WARRANTY

The limited warranty is not applicable unless these installation instructions are followed.

HOMEOWNER INFORMATION

A. COMBUSTION AIR SUPPLY

Your burner requires an ample amount of clean combustion air in order, to completely and efficiently burn its fuel. If an ample supply is not available erratic operation, noise combustion, and fuel odours in the air may result. REMEMBER THAT VENTING FANS OR A VENTER DRYER WILL GREATLY INCREASE THE NEED FOR OUTSIDE AIR.

B. AREA AROUND THE BOILER

The area around the boiler should be kept clean and free of any combustible materials, particularly oily rags or papers. The boiler should be accessible for ease of service.

SERVICE INFORMATION

To avoid unnecessary expense and inconvenience, the boiler and burner, should be inspected at least once a year by a qualified serviceman. If difficulty occurs, the following should be observed before calling the serviceman:

- A. Check to see if the thermostat setting is above room temperature
- B. Check to see if the service switch is in the on position

DO NOT TAMPER WITH THE UNITS OR CONTROLS

POWER FAILURE

In case of power failure the combustion fan will stop and the fuel feeding motors will stop feeding fuel to the fire pot. If this happens switch the primary control on/off switch to DRAFT FAN. Should the power come back while the fire is smouldering the emissions will be evacuated from the boiler, also this will prevent fuel from being fed into the fire pot. When power is resumed and the fire is extinguished the boiler can be safely restarted following the **START-UP INSTRUCTIONS**.

PB150 BOILER WIRING

Power Requirements:
 110 Volts
 15 Amps max
 Wire through a service switch.
 Surge protection required.

Low Limit Snap Disc

Low Water Cutoff

Vacuum Switch

Cup Motor

Auger Motor

Manual Resettable
 High Limit Snap Disc

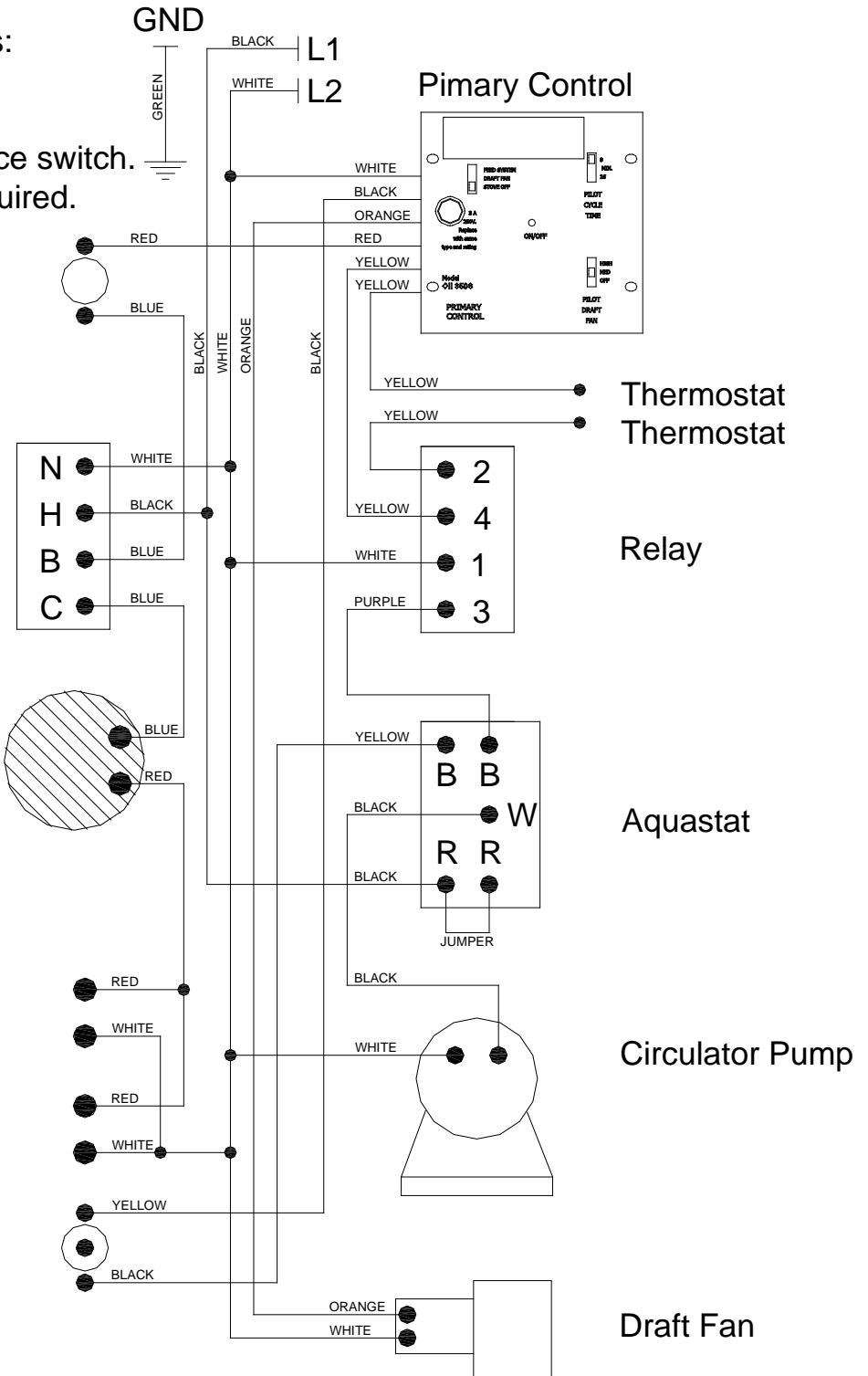

Figure 7

BURNING CORN IN THE PB150

1. The PB150 will burn most types of clean-shelled corn. It is not necessary to mix the corn with wood pellets, although some people have had good success burning a 50/50 mix. The PB150 boiler is supplied with a plug in the metering cup. When burning corn leave this plug in to prevent over fuelling the boiler.
2. Typically burning corn requires a bit more combustion air than wood pellets. The shutter on the draft inducer should be set at no less than 50% open, the cycle time at 8 minutes, and the pilot draft switch on the primary control medium.
3. The moisture content of the corn should be 15% or less, and care should be taken to ensure that there are no foreign objects in the corn (i.e. sticks, stalks, cob pieces) which will jam the feed system.
4. We recommend starting a corn fire with wood pellets as corn has a dense shell that can be difficult to start. Note that corn has more BTU's than wood pellets, about 10,000 BTU's per pound. Use gel starter to light unit.

WARNING

DO NOT USE CHEMICALS OR FLUIDS TO START THE FIRE.

DO NOT BURN GARBAGE, GASOLINE, NAPHTHA, ENGINE OIL OR OTHER INAPPROPRIATE MATERIALS.

5. When burning corn, the primary combustion takes place on a fluidized bed at the bottom of the fire pot. That's why the corn pot has a slide bottom. The slide bottom corn pot will need to be cleaned about once every 300 – 400 pounds of corn (approx. 4 – 6 days). A white calcium-like deposit will be present in the bottom of the fire pot. This deposit needs to be removed. We recommend shutting off the unit by turning the on/off switch on the primary control to the off position, letting the unit cool, and then pull the slide bottom completely out. You may have to tap the top of the deposit to make it fall into the ash pan. **We would recommend purchasing an extra pot to make cleaning easier.** Let the pot cool **completely** to the touch and place into a bucket of water to dissolve the clinker. **DO NOT PLACE HOT POT IN WATER.** You can also let the pot sit in the air for 2-3 days then dump the residue out. **DO NOT USE ANY OBJECT TO POUND OUT THE CLINKER. THIS WILL DAMAGE YOUR POT. THERE IS NO WARRANTY ON BURN POTS.**
6. Place 1" of course oyster shell in the bottom of the pot before using. Under heavy usage it may be necessary to remove the clinker daily. A bit of oyster shell will be removed with the clinker. When all oyster shell has been removed, remove pot for a thorough cleaning and replace with new pot, or clean and replace oyster shell and pot.

START UP INSTRUCTIONS

1. Make sure service switch to boiler is off.
2. Make sure boiler has been filled with water until entire system has been purged and desired pressure is obtained.
3. Check all fittings for leaks.
4. The PB150 boiler is supplied with a plug in the metering cup. If burning wood pellet only, this plug can be removed to increase firing rate.
5. Add fuel to the hopper. If burning corn add oyster shell to the pot.
6. Set shutter on draft fan at 50% (1/2 way open).
7. On the aqua stat set the high limit control on the left side at 200° F., low limit control on the right side at 160° F. and the differential setting at 130° F. This is the factory-preset level.
8. Set primary control (OII350S) cycle time switch at **8 minutes** and pilot draft switch at **Medium**. Turn on service switch.
9. Place two (4) cups of pellets in the bottom of the fire pot. Apply a non-volatile lighting material on top of pellets and light with a match.

WARNING

DO NOT USE CHEMICALS OR FLUIDS TO START THE FIRE.

DO NOT BURN GARBAGE, GASOLINE, NAPHTHA, ENGINE OIL OR OTHER INAPPROPRIATE MATERIALS.

10. Close door and let fire establish. Set on/off switch on primary control to **Feed System**
11. Combustion fan should come on to high speed. The fire in the pot will increase. When the safety disc on the smoke collector box reaches 49°C (120°F) temperature, it will close, and then the cup and auger motor will start adding more fuel to the fire pot. The unit will run until it reaches 160°F at which time the burner will cycle into pilot mode and the circulation pump will come on to supply hot water throughout the system.

FUEL QUALITY

Pellet quality is very important, please read the following:

Your PB150 boiler has been designed to burn wood pellet or shelled corn. Do not use any other type of fuel, as this will void any warranties stated in this manual.

The performance of your boiler is greatly affected by the type and quality of wood pellets being burned. As the heat output of various quality wood pellets differs, so will the performance and heat output of the pellet stove.

To prevent creosote formation a small intense fire is preferable to a large smouldering fire.

CAUTION: It is important to select and use only pellets that are dry and free of dirt or any impurities such as high salt content. Dirty fuel will adversely affect the operation and performance of the unit and will void the warranty. The Pellet Fuel Industries (P.F.I.) has established standards for wood pellet manufacturers. We recommend the use of pellets that meet or exceed these standards. Ask your dealer for a recommended pellet type.

P.F.I. PELLET STANDARDS:

Fines (fine particles).....1% maximum through a 1/8" screen

Bulk Density.....40 pound per cubic foot minimum

Size.....1/4" to 5/16" diameter 1/2 – 1 1/2" long maximum

Ash Content.....1% maximum (Premium grade)

.....3% maximum (Standard grade)

Moisture Content.....8% maximum

Heat Content.....approximately 8200 Btu per pound minimum

ASH: The ash content of the fuel and operation of your boiler will directly determine the frequency of cleaning. The use of high ash fuels may result in the boiler needing to be cleaned daily. A low ash fuel may allow longer intervals between cleaning.

CLINKERING: Clinkers are silica (sand) or other impurities in the fuel that will form a hard mass during the burning process. This hard mass will block the airflow through the Burn Pot and affect the performance of the boiler. Any fuel, even approved types, may tend to clinker. Check the Burn-Pot daily to ensure that the holes are not blocked with clinkers. If they become blocked, remove the burn-pot (when the unit is cold) and clean/scrape the clinkers out. Clean the holes with a small pointed object if required. Refer to the Maintenance section.

PELLET FEED RATES: Due to different fuel densities and sizes, pellet feed rates may vary. This may require an adjustment to the slider damper setting.

Pinnacle Stove Sales has no control over the quality of wood pellets or shelled corn that you use, we assume no liability for your choice in wood pellet or shelled corn fuel.

Store wood pellets or shelled corn at least 36 inches (1 m) away from the boiler. Do not store fuel within the appliance installation clearances or within space required for fuelling, ash removal, and other routine maintenance operations.

MAINTENANCE

UNIT MUST BE CLEANED AFTER APROXIMATELY 2 TONS OF FUEL TO ENSURE GOOD EFFICIENCY. MONITOR YOUR BOILER DAILY UNTIL EXPERIENCE SHOW HOW OFTEN CLEANING IS NECESSARY.

1. Ensure fire is out and boiler is sufficiently cooled to allow proper cleaning.
2. Switch primary control feed system switch to off. Turn off service switch.
3. Open the fire door and remove the slide bottom on the fire pot. Close the fire door.
4. Remove top cover by first taking off the 4 phenolic knobs and washers found on top corner of the cover box.
5. Remove the tube baffles by lifting them straight up. There are 14 of them.
6. Run a 3" diameter brush down thru the 3" diameter tubes. Be sure. Push brush all the way through the tube.
7. Use an approved **Ash Vacuum (not your house vacuum)** to clean the top of the heat exchanger.
8. Re-assemble the top of the boiler
9. On a non-combustible surface, well away from combustible materials have ready a fireproof container with a tight fitting lid, to receive ash. Open the fire door. Remove and thoroughly clean fire pot. Remove the ash pan; carefully dump ashes into the fireproof container. Pending final disposal by burial in soil or otherwise locally dispersed they should be retained in the ash container until thoroughly cooled. Do not use the ash container to store other waste. Take care not to scrape the sides of the fire chamber. They are lined with high temperature ceramic firebrick insulation.
10. Inspect and clean chimney of soot, fly ash and possible creosote build up.
11. Replace fire pot
12. Replace fire pot slide.
13. Inspect fire door, ash door and smoke chamber lid gaskets to ensure they are in good condition to maintain proper seal, preventing leakage.
14. Securely close all doors.
15. Restart the boiler as per **START-UP INSTRUCTIONS.**

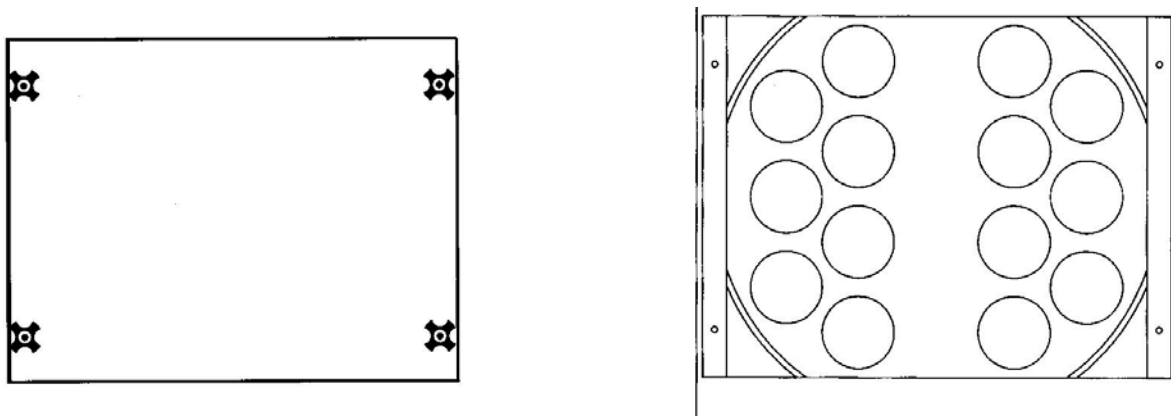

TOP VIEW

FIGURE 8

ALTERNATE PIPING AND WIRING CONNECTION

Not all existing systems may be 100% compatible with our PB150 boiler so an alternate method of connections can be used. These installation options should be discussed with your hydronic installation specialist to insure proper operation.

Primary and secondary loops

A primary loop of reasonable size of at least 1-¼" pipe from the supply to the return can be installed. The circulator pump can be wired into the R terminal on the aquastat allowing for constant operation. Zones are now connected to draw from the primary loop.

Thermostat Control

The yellow wires that are normally connected to a thermostat can be wired together bypassing the thermostat. The aquastat will now control water temperature based on the low limit settings. When the water reaches the low limit temperature the aquastat will shut down the burner to pilot mode until the water temperature drops below the low limit setting minus the differential setting. If the low limit setting is 170° F and the differential is 25° F, this means the burner will fire at the high rate until the water temperature reaches 170° F and then put the burner into pilot mode until the water temperature drops to 145° F.

Dump Zones

Be sure to incorporate a dump zone into the system. The dump zone can be controlled by using a strap on aquastat connected to the supply piping above the boiler.

Lockout Control

When connecting in series or parallel with an existing system, an interrupt to the call for heat may be needed to prevent both boilers from firing. A normally closed 120° F snap switch can be installed on the smoke box of the PB150 boiler and wired into the thermostat circuit of the existing boiler preventing the existing boiler from firing while the PB150 boiler is in operation. Be sure that when the PB150 boiler is not being used to shut off its power via the service switch.

PINNACLE STOVE SALES WARRANTY

NON TRANSFERABLE

MODEL: PB150 SERIAL NUMBER: _____

DATE PURCHASED: _____ FROM: _____

Complete Unit Warranty

The manufacturer provides a warranty on all steel parts (except burn pot) and electrical components against defects in material or workmanship under normal use and maintenance for a period of one (1) year from the installation date. There is expressly no warranty on the following components: burn pots, firebrick, fibreglass rope gasket, paint, or gaskets. This warranty covers defects in materials and workmanship in covered components, provided the product has been installed and operated strictly in accordance with Manufacturer's printed instructions. This warranty does not cover damage or breakage caused by improper handling, misuse or unauthorized modification. Without limiting the foregoing, the use of fuels other than pelletized wood or fuel corn will void all warranties and liabilities. **Commercial applications** are warranted for a period of three (3) months on steel parts and electrical components. Pinnacle Stoves Sales Inc. reserves the right to determine commercial applications. All claims under this warranty must be made in writing to the Manufacturer at Pinnacle Stove Sales Inc, 1089 Hwy 97N, Quesnel, BC V2J 2Y3 and should include the following.

1. Name, address, and telephone number of servicing dealer.
2. Name, address, and telephone number of purchaser
3. Date of purchase
4. Model & serial number of unit.

5. Nature of the defect, malfunction and/or complaint. Local representatives are to inspect parts and or unit. If the inspection indicates that the failure was due to defective material or workmanship in covered components and that the other terms and conditions of this warranty have been complied with the manufacturer's sole duty and liability under this warranty shall be limited to the manufacturer's replacement or repair, at manufacturer's option, of the defective unit or part. The purchaser shall assume all costs of shipping to and from the manufacturer. Removal, reinstallation and diagnostic costs are not covered under this warranty.

Extended Parts Warranty

In addition to the above complete unit warranty, the following applies:

- Five (5) year extended warranty, pro-rated, on boiler vessel, **residential** use.
- One (1) year extended warranty, pro-rated, on boiler vessel, **commercial** use

NEITHER THE MANUFACTURER, NOR THE SUPPLIER TO THE PURCHASER, ACCEPTS RESPONSIBILITY, LEGAL OR OTHERWISE, FOR INCIDENTAL OR CONSEQUENTIAL DAMAGE TO PROPERTY OR PERSONS RESULTING FROM THE USE OF THIS PRODUCT, ANY WARRANTY IMPLIED BY LAW, INCLUDING BUT NOT LIMITED TO IMPLIED WARRANTIES OF MERCHANTABILITY OR FITNESS, SHALL BE LIMITED TO ONE YEAR FROM THE DATE OF ORIGINAL PURCHASE. WHETHER A CLAIM IS MADE AGAINST THE MANUFACTURER BASED ON A BREACH OF THIS WARRANTY OR ANY OTHER TYPE OF WARRANTY, EXPRESSED OR IMPLIED BY LAW, MANUFACTURER SHALL IN NO EVENT BE LIABLE FOR ANY SPECIAL, INDIRECT, CONSEQUENTIAL OR OTHER DAMAGES OF ANY NATURE WHATSOEVER IN EXCESS OF THE ORIGINAL PURCHASE PRICE OF THIS PRODUCT. ALL WARRANTIES BY MANUFACTURER ARE SET FORTH HEREIN AND NO CLAIM SHALL BE MADE AGAINST MANUFACTURER ON ANY ORAL WARRANTY OR REPRESENTATION.

Some states/provinces may not allow the exclusion or limitation of consequential damages, or limitations of implied warranties, so the limitations or exclusions set forth in this warranty may not apply to you. This warranty gives you specific legal rights and you may also have other rights, which vary from state to state, province to province.

TROUBLE SHOOTING GUIDE

Tools Essential for Trouble Shooting

1. Furnace Installation and Operation manual
2. Circuit Tester / Volt Meter
3. Molex pin Extractor
4. Volt Meter

STEP #1

ATTENTION: Before attempting any trouble shooting:

1. Check your wiring to control box to insure proper polarity and grounding.
2. Check flue for any blockage.
3. Take time to clean burn pot and heat exchangers.
4. If you have replaced the fan limit control, make sure the brass connector in the middle has been removed or snipped.

STEP #2

CONFIRM POWER TO CONTROL BOARD

Turn Main power switch from the "Stove Off" position to the "Draft Fan" position. If the red indicator light comes on, there is power to the control board. If the light does not come on check the following:

- A. Power Source (See Step #1)
- B. Fuse
- C. Burner Manual Reset – If the fuse is not blown and the reset button has not popped out, inspect the Molex connection. Finally, using a voltmeter, check for power at the power switch. If the meter indicates 115v and the light still doesn't come on, replace the control board.

STEP 3#

CONFIRM DRAFT FAN OPERATION

Be sure the main power switch is in the "Draft Fan" position. This will cause the draft fan to operate at full power (115v). The draft fan will operate at 70 – 75v when pilot draft switch is set at high. It will receive 60 – 65v in the medium position and zero volts in the off position when furnace is not feeding fuel. You should be able to hear the draft fan come to full speed. You can check movement of air by placing your hand over the fire pot. If movement of air is not obvious, make sure that the shutter is open.

STEP #4

INSPECT FUEL METERING CUP FOR BLOCKAGE

To inspect the metering cup, first you will need to empty the hopper. Reach down through the hopper and rock the cup back and forth. The cup should move ¼ of an inch. If it does not move, something is jamming it. Sometimes the obstruction can be removed by rotating the blade on the cup motor counter clockwise. If this doesn't work you will have to remove the cup motor and cup to remove the blockage.

STEP #5

CONFIRM CUP AND AUGER MOTOR OPERATION

Place a jumper wire between the leads to the safety disc located on the exhaust flange. Set the main power switch to "feed system". Both the cup and auger motor should start now. If the motors run but the fuel metering cup and/or auger do not turn, check the cast iron couplers to make certain that the set screw is tight or that a coupler has not snapped off. NOTE: Anytime you are checking the motors, you should verify the speed at which motors are turning. This can be accomplished by timing the revolution of the coupler. Using the setscrew as a reference the bottom motor (Auger) will make one revolution in 10 seconds. The top motor (cup) will make approximately one revolution every 45 seconds. Remove jumper wire and plug wire leads back to safety disc.

STEP #6 RELIGHT THE BOILER

Use normal start up procedure to start the boiler.

INSTALLATION/ADJUSTMENT RELATED PROBLEMS

PROBLEM: **Incomplete combustion, unburned fuel.**

SOLUTION: 1. Adjust air shutter to a more open position.
2. Make sure of correct chimney, is chimney drafting?
Is the chimney direct vented? Is it a tight basement?
Outside air may be needed. What is fuel moisture?

PROBLEM: **Burns fuel too quickly and may have difficulty holding a fire on pilot.**

SOLUTION: Adjust air shutter to a more closed position. If that doesn't solve the problem, check for an over drafting chimney by using a draft gauge. To solve over drafting use the following procedures:

Masonry Chimney: Cover top with a plate and mount a 4" cap. If that doesn't slow it down, use a barometric damper.

Pellet Vent: Install a barometric damper.

PROBLEM: **Smoking**

SOLUTION: Make sure that the chimney is not direct vented on a windy side of the house. Also check gaskets to insure proper sealing. Adjust damper opening, might be too far closed.
Is heat exchanger clean? Is chimney clean?

PROBLEM: **Auger squeaks**

SOLUTION: Adjust pillow block bearing by loosening screws on each side.

Let auger run for one minute. Tighten screws. Auger should realign itself. Possible build up of carbon on end of auger where it enters burn pot.

PROBLEM: **Decrease in heat output**
SOLUTION: Thoroughly clean heat exchanger. Did you start using different fuel? Shutter on draft fan moved?

OPERATOR RELATED PROBLEMS

PROBLEM: **Feed system does not lock in.**
SOLUTION: Repeat start up using more fuel.

PROBLEM: **Boiler will not start up after power outage.**
SOLUTION: Check manual reset on feed system.

PROBLEM: **Boiler will not feed fuel.**
SOLUTION: Check for blockage in metering cup.
Is there fuel in the hopper?

FUEL RELATED PROBLEMS

Symptoms of Poor Fuel:

1. Unburned pellets
2. Fire pot overflows as a result of high moisture content.
3. Lack of heat.
4. Excessive ash build-up.
5. Incorrect size.

PARTS LIST

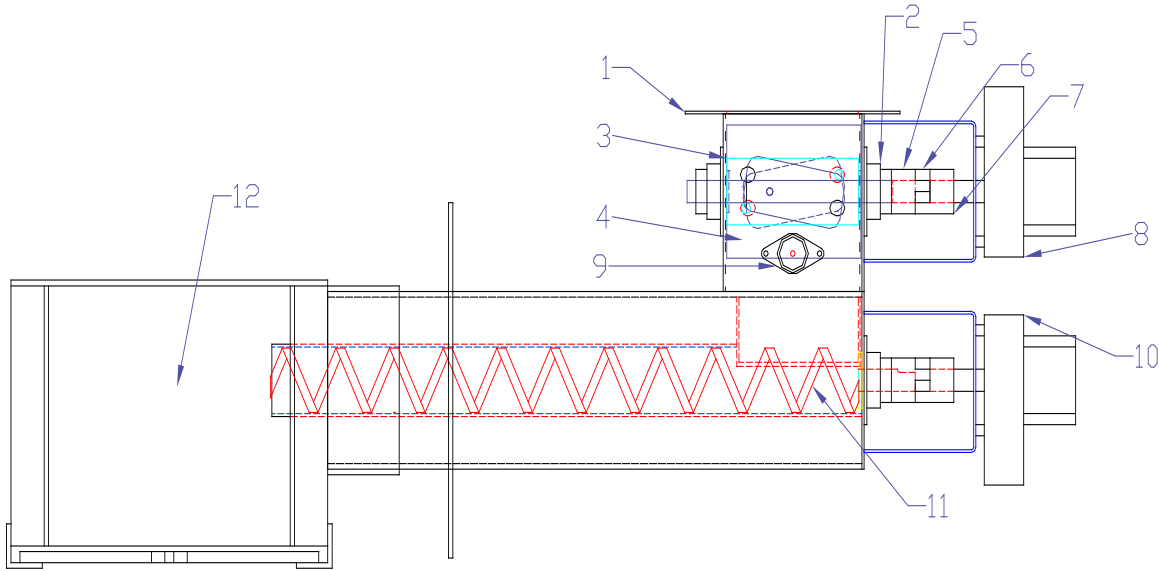

Figure 10

1. Hopper connector flange	F000221P	8. Cup motor	F000101P
2. Pillow block ball bearing	F000505P	9. Manual reset	F000105P
3. Cutting blades (2) ea.	F000513P-2	10. Auger motor	F000102P
4. Fuel metering cup	F130512P	11. Auger/shaft assembly	F150293P
5. 1/2" lovejoy coupling	F000507P	12. Multi fuel burn pot	F150999S
6. Spider	F000505P		
7. 1/2" lovejoy coupling	F000507P		

NOTES