

# Owner's Manual

## Operation & Care

**INSTALLER:** Leave this manual with party responsible for use and operation.

**OWNER:** Retain this manual for future reference.

Contact your dealer with questions on installation, operation, or service.

**NOTICE: DO NOT DISCARD THIS MANUAL**

# QUADRA-FIRE®

## Explorer II Medium Wood Stove

**Model(s):**

**EXPLRMED-PBK**

**EXPLRMED-PDB**

**EXPLRMED-PFT**

**EXPLRMED-PMH**

**EXPLRMED-MBK**

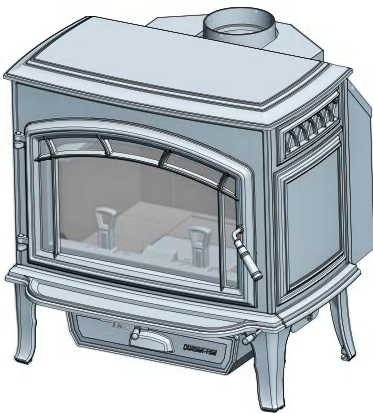

### **WARNING**



**Fire Risk.**

For use with solid wood fuel only.  
Other fuels may overfire and generate poisonous gases (i.e. carbon monoxide).

**myhht**  
**FACTORY**  
training

Installation and service of this appliance should be performed by qualified personnel. Hearth & Home Technologies recommends NFI certified professionals, or technicians supervised by an NFI certified professional.



### **WARNING**



If the information in these instructions is not followed exactly, a fire may result causing property damage, personal injury, or death.

- Do not store or use gasoline or other flammable vapors and liquids in the vicinity of this or any other appliance.
- Do not overfire - If heater or chimney connector glows, you are overfiring. Overfiring will void your warranty.
- Comply with all minimum clearances to combustibles as specified. Failure to comply may cause house fire.

### **WARNING**



**HOT SURFACES!**

Glass and other surfaces are hot during operation AND cool down.

**Hot glass will cause burns.**

- Do not touch glass until it is cooled
- NEVER allow children to touch glass
- Keep children away
- CAREFULLY SUPERVISE children in same room as fireplace.
- Alert children and adults to hazards of high temperatures
- **High temperatures may ignite clothing or other flammable materials.**
- Keep clothing, furniture, draperies and other flammable materials away.

### **NOTE**

To obtain a French translation of this manual, please contact your dealer or visit [www.quadrafire.com](http://www.quadrafire.com)

Pour obtenir une traduction française de ce manuel, s'il vous plaît contacter votre revendeur ou visitez [www.quadrafire.com](http://www.quadrafire.com)

# Congratulations



and Welcome to the Quadra-Fire Family!

## A. Congratulations

Hearth & Home Technologies welcomes you to our tradition of excellence! In choosing a Quadra-Fire appliance, you have our assurance of commitment to quality, durability, and performance.

This commitment begins with our research of the market, including 'Voice of the Customer' contacts, ensuring we make products that will satisfy your needs. Our Research and Development facility then employs the world's most

advanced technology to achieve the optimum operation of our stoves, inserts and fireplaces. And yet we are old-fashioned when it comes to craftsmanship. Each unit is meticulously fabricated and gold and nickel surfaces are hand-finished for lasting beauty and enjoyment. Our pledge to quality is completed as each model undergoes a quality control inspection.

We wish you and your family many years of enjoyment in the warmth and comfort of your hearth appliance. Thank you for choosing Quadra-Fire.

**NOTE: Clearances may only be reduced by means approved by the regulatory authority having jurisdiction**

## B. Sample of Serial Number / Safety Label

LOCATION: Back of unit

**CAUTION:** HOT WHILE IN OPERATION DO NOT TOUCH, KEEP CHILDREN AND CLOTHING AWAY. CONTACT MAY CAUSE SKIN BURNS.  
**ATTENTION:** CHAUD LORS DE L'OPÉRATION. NE PAS TOUCHER. GARDEZ LES ENFANTS ET LES VÊTEMENTS LOIN DE L'ESPACE DÉSIGNÉ DE L'INSTALLATION. LE CONTACT PEUT CAUSER DES BRÛLURES À LA PEAU. GARDEZ LES MEUBLES ET LES MATÉRIEAUX COMBUSTIBLES LOIN DE L'ESPACE DÉSIGNÉ DE L'APPAREIL. VOIR L'ÉTIQUETTE ET LES INSTRUCTIONS.

**PREVENT HOUSE FIRES**  
Install and use only in accordance with manufacturer's installation and operating instructions. Contact local building or fire officials about restrictions and installation inspections in your area. Do not obstruct the space beneath heater.  
**WARNING - For Mobile Homes:** Do not install in a sleeping room. An outside combustion air inlet must be provided and unrestricted while unit is in use. The structural integrity of the mobile home floor, ceiling and walls must be maintained. The stove needs to be properly grounded to the frame of the mobile home. Components required for mobile home installation: Outside Air Kit, Part Number OAK-ACC. Refer to manufacturer's instructions and local codes for precautions required for passing chimney through a combustible wall or ceiling and maximum offsets. Inspect and clean chimney frequently. Under Certain Conditions of Use, Cresosote Buildup May Occur Rapidly. Do not connect this unit to a chimney serving another appliance. Optional Components: Optional Blower, Part BK-ACC. Electrical Rating: 115 VAC, 1.2 Amps, 60 Hz. Route power cord away from unit. Do not route cord under or in front of appliance. **DANGER: Risk of electrical shock.** Disconnect power supply before servicing. Replace glass only with 5mm ceramic available from your dealer. Do not use grate or elevate fire. Build wood fire directly on hearth. Do not overfire - if heater or chimney connector glows, you are overfiring. Operate only with the fuel loading door closed. Open only to add fuel to the fire.

**FLOOR PROTECTION:** Floor protector must be Type I ember protection with no minimum R value extending beneath heater and to front/sides/rear as indicated on the diagram. Exception: Non-combustible floor protections must extend beneath the flue pipe when installed horizontally venting and extend 2 inches (51mm) beyond each side.

**APPAREIL DE CHAUFFAGE DE PIÈCE. DE TYPE DE COMBUSTIBLE SOLIDE. PAS APPROUVÉ POUR MOBILE HOME INSTALLATIONS AU CANADA. Pour Usage Avec Bois Solide Seulement**

**PREVENTION DES FEUX DE MAISON**  
Installez et utilisez en accord avec les instructions d'installation et d'opération du fabricant. Contactez le bureau de la construction ou le bureau des incendies au sujet des restrictions et des inspections d'installation dans votre voisinage. Ne pas obstruer l'espace en dessous de l'appareil. PAS APPROUVÉ POUR MOBILE HOME INSTALLATIONS AU CANADA!  
Référez-vous aux instructions du fabricant et des codes locaux pour les précautions requises pour passer une cheminée à travers un mur ou un plafond combustibles, et les compensations maximales. Inspectez et nettoyez la cheminée fréquemment. Sous certaines conditions, il se peut que la cressote s'accrue rapidement.  
Ne pas connecter cet appareil à une cheminée servant un autre appareil. Composants Optionnels: Ventilateur Optionnel, Pièce BK-ACC. Puissance Électrique: 115 VAC, 1.2 Amps, 60 Hz. Éloignez le fil électrique de l'appareil. Ne pas faire passer le fil électrique au dessus ou en dessous de l'appareil. **DANGER:** Il y a risque de décharge électrique. Déconnectez le fil électrique de la prise de contact avant le service. Remplacez la vitre seulement avec une vitre céramique de 5 mm disponible chez votre fournisseur. N'élevez pas le feu. Bâillez le feu de bois directement sur l'âtre. Ne pas surchauffer. Si l'appareil de chauffage ou le tuyau de cheminée rougissent, vous surchauffez. Opérez l'appareil seulement lorsque la porte de chargement est fermée. Ouvrez la porte seulement lorsque vous devez ajouter des combustibles dans le feu.

**PROTECTION DE PLANCHER:** Protecteur de plancher doit être une protection braises sans valeur R minimale s'étendant sous l'appareil et à l'avant / côtés / arrière conformément au diagramme. Exception: Protections de sol non combustibles doivent s'étendre au-dessous de la conduite de ventilation horizontale et s'étendre 2 po (51 mm) de chaque côté.

**Intertek** 4001508

**Quadra-Fire**  
NOTHING BURNS LIKE A QUAD  
TESTED TO / TESTÉ À:  
Conforms to UL Sids 1462 & T37  
Certified to ULC Std S627

**EXPLORER II WOOD STOVE**

SERIAL NO. / NUMÉRO DE SÉRIE  
**007062**

**VENT SPECIFICATIONS:**  
SINGLE WALL: Six inch (6 inches) (152mm) diameter, minimum 24 MSG black or blue steel connector pipe, with a listed factory-built UL103HT\* Class "A" chimney, suitable for use with solid fuels, or a masonry chimney, and the referenced clearances.  
DOUBLE WALL: Six inch (6 inches) (152mm) diameter, listed double wall air insulated connector pipe with listed factory-built UL103HT\* Class "A" chimney, or a masonry chimney and the referenced clearances  
**\*In Canada, must comply with Standard CAN/ULC-S629-M87 for the 650 degree Factory-built chimneys.**  
MOBILE HOME (USA ONLY): Use double wall pipe by Dura-Vent DVL, Selkirk Metalbestos DS or Security DL double wall connector pipe. Must be equipped with a spark arrester. Apply double wall clearances below when installing unit.  
MINIMUM CLEARANCES TO COMBUSTIBLES: In Inches & (Millimeters)  
NOTE: All "A", "C" and "F" Dimensions are to inside diameter of the flue pipe.

**SPECIFICATIONS DE LA VENTILATION:**  
MUR SIMPLE: De six (6 inches) (152mm) de diamètre le connecteur de conduit de minimum 24 MSG noir ou bleu acier, avec une cheminée bâtit en usine UL103HT\* de Classe "A", adéquate pour usage avec les combustibles solides, ou une cheminée en maçonnerie, avec espaces libres référés.  
MUR DOUBLE: De six (6 inches) (152mm) de diamètre, le connecteur du conduit d'air isolé avec une cheminée bâtit en usine UL103HT\* de Classe "A", ou une cheminée en maçonnerie, avec espaces libres autorisés.  
**\*Au Canada, doit être conforme à la norme pour 650 degrés C cheminée bâtit en usine CAN/ULC-S629-M87 la norme pour 650 degrés C cheminée bâtit en usine.**  
MAISON MOBILE: Utilisez un tuyau double par Dura-Vent DVL, Selkirk Metalbestos DS ou Security DL double wall connector pipe. Doit être équipé d'un pare-étincelles. Appliquez les dimensions de mur double ci-dessous lors de l'installation de l'unité.  
ESPACE LIBRE MINIMUM (millimètres)  
NOTE: Toutes les dimensions "A", "C", et "F" sont à partir du diamètre intérieur de l'entrée du conduit.

	A	B	C	D	E	F	G	H	I	J	K
SINGLE WALL PIPE	7.5 (191)	6.3 (162)	17.25 (438)	6.5 (165)	7.0 (178)	10.0 (257)	55 (1397)	NA	NA	NA	CONDUIT DU MUR SIMPLE
DOUBLE WALL PIPE	6.38 (162)	5.38 (137)	17.25 (438)	6.5 (165)	4.5 (114)	7.5 (191)	55 (1397)	NA	NA	NA	CONDUIT DU MUR DOUBLE
INSTALLATION THROUGH BACKWALL	19 (483)	5.38 (137)	17.25 (438)	6.5 (165)	NA	NA	55 (1397)	26.25 (667)	NA	NA	CONDUIT DU MUR DOUBLE
INSTALLATION THROUGH SIDE WALL	NA	NA	17.25 (438)	6.5 (165)	NA	NA	55 (1397)	NA	12 (305)	50 (1270)	CONDUIT DU MUR SIMPLE

**INSTALLATION THROUGH BACKWALL:** Six inch (6 inches) (152mm) diameter listed SINGLE WALL or DOUBLE WALL air insulated connector pipe with UL 103 HT listed factory-built Class "A" chimney, or a masonry chimney. (Mobile Home must be equipped with a spark arrester). Maximum depth of Alcove shall be no more than 48 inches (1219mm) with a minimum height of 84 inches (2133mm) from floor to bottom of ceiling, and the referenced clearances.

**INSTALLATION ALCOVE:** De six (6 inches) (152mm) de diamètre, le connecteur du conduit d'air isolé pour du mur simple ou mur double avec une cheminée bâtit en usine 103HT de Classe "A", ou une cheminée de briques. (Les maisons mobiles doivent être équipées d'un arrêt d'étincelle). La profondeur maximum de l'alcove ne doit pas être de plus de 48 inches (1219mm) avec une hauteur minimum de 84 inches (2133mm) la distance entre du plancher et du plafond inférieur, et des espaces libres autorisés.

**BACKWALL/SIDEWALL MUR ARRIÈRE/MUR DE CÔTÉ**  
**CORNER INSTALLATION INSTALLATION DU COIN**  
**80" OFF TOP UP & OUT CEILING CLEARANCE ESPACE LIBRE DU DESSUS DE L'APPAREIL AU PLAFOND AVEC 80" DE COURBURE**  
**HORIZONTAL THRU WALL HORIZONTALE AU MUR**

Manufactured by:

**HEARTH-HOME**  
1425 N. Highway, Coville, WA 99114  
www.quadrafire.com

U.S. ENVIRONMENTAL PROTECTION AGENCY  
Certified to comply with 2010 particulate emission standards at 2.2 g/hr EPA method 28 and 5G. Not approved for sale after May 15, 2020.

This wood heater needs proper operation. Consult the owner's manual for further information. It is against federal regulations to operate this wood heater in a manner inconsistent with the operating the owner's manual.

Mfg. Date

JAN FEB MAR APR MAY JUN JUL AUG SEP OCT NOV DEC

DO NOT REMOVE THIS LABEL / NE PAS ENLEVER L'ÉTIQUETTE

7061-175E

**Safety Alert Key:**

- **DANGER!** Indicates a hazardous situation which, if not avoided will result in death or serious injury.
- **WARNING!** Indicates a hazardous situation which, if not avoided could result in death or serious injury.
- **CAUTION!** Indicates a hazardous situation which, if not avoided, could result in minor or moderate injury.
- **NOTICE:** Indicates practices which may cause damage to the appliance or to property.

**TABLE OF CONTENTS**

A. Congratulations.....	2	<b>3 Maintenance and Service .....</b>	<b>14</b>
B. Sample of Serial Number / Safety Label .....	2	A. Quick Reference Maintenance Guide.....	14
C. Warranty Policy .....	4	B. General Maintenance .....	15
D. Quick Start Guide .....	6	<b>4 Troubleshooting Guide.....</b>	<b>17</b>
<b>1 Listing and Code Approvals .....</b>	<b>7</b>	<b>5 Service Part Replacement.....</b>	<b>18</b>
A. Appliance Certification .....	7	A. Glass Replacement .....	18
B. BTU & Efficiency Specifications.....	7	B. Firebrick Replacement .....	18
C. Mobile Home Approved (USA ONLY).....	7	C. Snap Disc Replacement .....	19
D. Glass Specifications .....	7	D. Door Handle Assembly.....	19
<b>2 Operating Instructions .....</b>	<b>8</b>	E. Baffle Removal .....	19
A. Over-Firing Your Appliance.....	8	F. Tube Channel Assembly Replacement .....	20
B. Wood Selection & Storage.....	8	<b>6 Reference Materials .....</b>	<b>21</b>
C. Burning Process .....	8	A. Service & Maintenance Log.....	21
D. Automatic Combustion Control (ACC).....	9	B. Service Parts & Accessories.....	22
E. Air Controls .....	9		
F. Burn Rates and Operating Efficiency .....	10		
G. Building A Fire .....	10		
H. Correct Baffle & Blanket Placement .....	11		
I. Blower Operating Instructions .....	12		
J. Opacity (Smoke) .....	12		
K. Negative Pressure .....	13		
L. Frequently Asked Questions .....	13		

C. Warranty Policy

Hearth & Home Technologies Inc.  
LIMITED LIFETIME WARRANTY

Hearth & Home Technologies Inc., on behalf of its hearth brands ("HHT"), extends the following warranty for HHT gas, wood, pellet, coal and electric hearth appliances that are purchased from an HHT authorized dealer.

**WARRANTY COVERAGE:**

HHT warrants to the original owner of the HHT appliance at the site of installation, and to any transferee taking ownership of the appliance at the site of installation within two years following the date of original purchase, that the HHT appliance will be free from defects in materials and workmanship at the time of manufacture. After installation, if covered components manufactured by HHT are found to be defective in materials or workmanship during the applicable warranty period, HHT will, at its option, repair or replace the covered components. HHT, at its own discretion, may fully discharge all of its obligations under such warranties by replacing the product itself or refunding the verified purchase price of the product itself. The maximum amount recoverable under this warranty is limited to the purchase price of the product. This warranty is subject to conditions, exclusions and limitations as described below.

**WARRANTY PERIOD:**

Warranty coverage begins on the date of original purchase. In the case of new home construction, warranty coverage begins on the date of first occupancy of the dwelling or six months after the sale of the product by an independent, authorized HHT dealer/ distributor, whichever occurs earlier. The warranty shall commence no later than 24 months following the date of product shipment from HHT, regardless of the installation or occupancy date. The warranty period for parts and labor for covered components is produced in the following table.

The term "Limited Lifetime" in the table below is defined as: 20 years from the beginning date of warranty coverage for gas appliances, and 10 years from the beginning date of warranty coverage for wood, pellet, and coal appliances. These time periods reflect the minimum expected useful lives of the designated components under normal operating conditions.

Warranty Period		HHT Manufactured Appliances and Venting							Components Covered
Parts	Labor	Gas	Wood	Pellet	EPA Wood	Coal	Electric	Venting	
1 Year		X	X	X	X	X	X	X	All parts and material except as covered by Conditions, Exclusions, and Limitations listed
2 years				X	X	X			Igniters, electronic components, and glass
		X	X	X	X	X			Factory-installed blowers
				X					Molded refractory panels
3 years				X					Firepots and burnpots
5 years	1 year			X	X				Castings and baffles
7 years	3 years		X	X	X				Manifold tubes, HHT chimney and termination
10 years	1 year	X							Burners, logs and refractory
Limited Lifetime	3 years	X	X	X	X	X			Firebox and heat exchanger
90 Days		X	X	X	X	X	X	X	All replacement parts beyond warranty period

See conditions, exclusions, and limitations on next page.

**WARRANTY CONDITIONS:**

- This warranty only covers HHT appliances that are purchased through an HHT authorized dealer or distributor. A list of HHT authorized dealers is available on the HHT branded websites.
- This warranty is only valid while the HHT appliance remains at the site of original installation.
- Contact your installing dealer for warranty service. If the installing dealer is unable to provide necessary parts, contact the nearest HHT authorized dealer or supplier. Additional service fees may apply if you are seeking warranty service from a dealer other than the dealer from whom you originally purchased the product.
- Check with your dealer in advance for any costs to you when arranging a warranty call. Travel and shipping charges for parts are not covered by this warranty.

**WARRANTY EXCLUSIONS:**

This warranty does not cover the following:

- Changes in surface finishes as a result of normal use. As a heating appliance, some changes in color of interior and exterior surface finishes may occur. This is not a flaw and is not covered under warranty.
- Damage to printed, plated, or enameled surfaces caused by fingerprints, accidents, misuse, scratches, melted items, or other external sources and residues left on the plated surfaces from the use of abrasive cleaners or polishes.
- Repair or replacement of parts that are subject to normal wear and tear during the warranty period. These parts include: paint, wood, pellet and coal gaskets, firebricks, grates, flame guides, light bulbs, batteries and the discoloration of glass.
- Minor expansion, contraction, or movement of certain parts causing noise. These conditions are normal and complaints related to this noise are not covered by this warranty.
- Damages resulting from: (1) failure to install, operate, or maintain the appliance in accordance with the installation instructions, operating instructions, and listing agent identification label furnished with the appliance; (2) failure to install the appliance in accordance with local building codes; (3) shipping or improper handling; (4) improper operation, abuse, misuse, continued operation with damaged, corroded or failed components, accident, or improperly/incorrectly performed repairs; (5) environmental conditions, inadequate ventilation, negative pressure, or drafting caused by tightly sealed constructions, insufficient make-up air supply, or handling devices such as exhaust fans or forced air furnaces or other such causes; (6) use of fuels other than those specified in the operating instructions; (7) installation or use of components not supplied with the appliance or any other components not expressly authorized and approved by HHT; (8) modification of the appliance not expressly authorized and approved by HHT in writing; and/or (9) interruptions or fluctuations of electrical power supply to the appliance.
- Non-HHT venting components, hearth components or other accessories used in conjunction with the appliance.
- Any part of a pre-existing fireplace system in which an insert or a decorative gas appliance is installed.
- HHT's obligation under this warranty does not extend to the appliance's capability to heat the desired space. Information is provided to assist the consumer and the dealer in selecting the proper appliance for the application. Consideration must be given to appliance location and configuration, environmental conditions, insulation and air tightness of the structure.

**This warranty is void if:**

- The appliance has been over-fired or operated in atmospheres contaminated by chlorine, fluorine, or other damaging chemicals. Over-firing can be identified by, but not limited to, warped plates or tubes, rust colored cast iron, bubbling, cracking and discoloration of steel or enamel finishes.
- The appliance is subjected to prolonged periods of dampness or condensation.
- There is any damage to the appliance or other components due to water or weather damage which is the result of, but not limited to, improper chimney or venting installation.

**LIMITATIONS OF LIABILITY:**

- The owner's exclusive remedy and HHT's sole obligation under this warranty, under any other warranty, express or implied, or in contract, tort or otherwise, shall be limited to replacement, repair, or refund, as specified above. In no event will HHT be liable for any incidental or consequential damages caused by defects in the appliance. Some states do not allow exclusions or limitation of incidental or consequential damages, so these limitations may not apply to you. This warranty gives you specific rights; you may also have other rights, which vary from state to state. EXCEPT TO THE EXTENT PROVIDED BY LAW, HHT MAKES NO EXPRESS WARRANTIES OTHER THAN THE WARRANTY SPECIFIED HEREIN. THE DURATION OF ANY IMPLIED WARRANTY IS LIMITED TO DURATION OF THE EXPRESSED WARRANTY SPECIFIED ABOVE.

D. Quick Start Guide

**Note:** These are generic drawings and may not represent your specific model.

**ITEMS NEEDED FOR FIRST FIRE:** 10 Pieces of Newspaper, 10-20 Pieces of Dry Kindling and a Few Pieces of Dry Split Wood.

**OPEN AIR CONTROLS**

see section E on pg. 9

1

**LOAD WOOD**

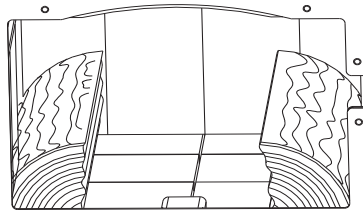

2

**ADD NEWSPAPER**

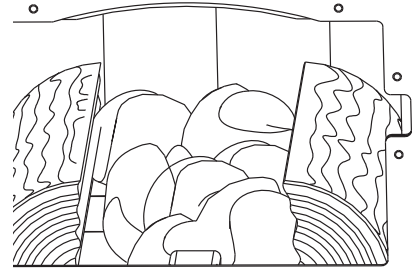

3

**ADD KINDLING**

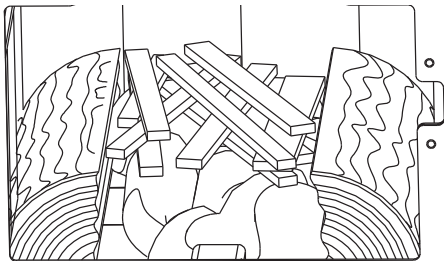

**LIGHT THE PAPER** 4

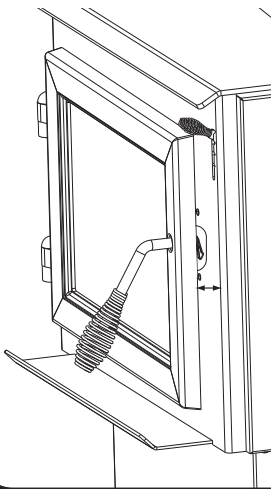

**WARNING! Risk of Fire**

Close and securely latch the door after the fire has started, and after refueling, to prevent:

- Spillage of smoke, flame and carbon monoxide
- Spillage of sparks, coals and logs
- Over-firing

DO NOT leave the stove unattended with the door open.

Starting a fire may not require an open door for draft. The air control should supply adequate draft.

5

**ADD MORE WOOD**

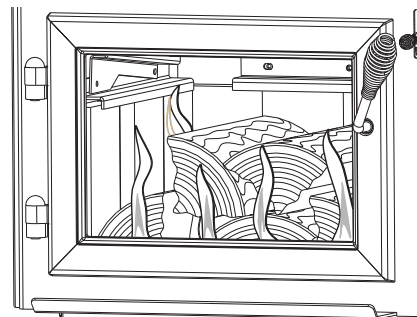

6

**REDUCE AIR CONTROL**

Set to desired heat output

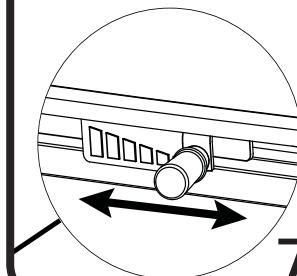

7

**The stove is ready for normal operation.**

# 1 Listing and Code Approvals

## A. Appliance Certification

<b>Model:</b>	Explorer II Wood Stove
<b>Laboratory:</b>	Intertek
<b>Report No &amp; Date:</b>	10126132PRT
<b>Type:</b>	Safety
<b>Standard:</b>	UL 1482-07; ULC S627-00

NOTE: This installation must conform with local codes. In the absence of local codes you must comply with the UL1482-07, (UM) 84-HUD and NPFA211 in the U.S.A. and the ULC S627-00 and CAN/CSA-B365 Installation Codes in Canada. **NOT APPROVED FOR MOBILE HOME INSTALLATIONS IN CANADA!**

## B. BTU & Efficiency Specifications

EPA Certification #:	925
EPA Certified Emissions:	2.2 grams per hour
*LHV Tested Efficiency:	78.3 %
**HHV Tested Efficiency:	72.4 %
***EPA BTU Output:	11,200 to 35,900 / hr.
****Peak BTU/Hour Output:	61,000
Vent Size:	6 inches
Firebox Size:	2.42 cubic feet
Maximum Wood Length:	20 inches
Ideal Wood Length:	18 inches
Fuel	Seasoned Cord Wood
* Weighted average LHV efficiency using Douglas Fir dimensional lumber and data collected during EPA emissions test.	
**Weighted average HHV efficiency using Douglas Fir dimensional lumber and data collected during EPA emissions test.	
***A range of BTU outputs based on EPA Default Efficiency and the burn rates from the low and high EPA tests, using Douglas Fir dimensional lumber.	
****A peak BTU out of the unit calculated using the maximum first hour burn rate from the High EPA Test and the BTU content of cordwood (8600) times the efficiency.	

The Quadra-Fire Explorer Series Wood Stove (ACC) meets the U.S. Environmental Protection Agency's crib wood emission limits for wood heaters sold after May 15, 2015.



This wood heater needs periodic inspection and repair for proper operation. It is against federal regulations to operate this wood heater in a manner inconsistent with operating instructions in this manual.

## C. Mobile Home Approved (USA ONLY)

- This appliance is approved for mobile home installations in the USA when not installed in a sleeping room and when an outside combustion air inlet is provided.
- The structural integrity of the mobile home floor, ceiling, and walls must be maintained.
- The appliance must be properly grounded to the frame of the mobile home with #8 copper ground wire, and chimney must be listed to UL103 HT or a listed UL-1777 full length six inch (152mm) diameter liner must be used.
- Outside Air Kit, part OAK-ACC must be installed in a mobile home installation.

## D. Glass Specifications

This stove is equipped with 5mm ceramic glass. Replace glass only with 5mm ceramic glass. Please contact your dealer for replacement glass.

 <b>WARNING</b>	
	<p><b>Fire Risk.</b></p> <p>Hearth &amp; Home Technologies disclaims any responsibility for, and the warranty will be voided by, the following actions:</p> <ul style="list-style-type: none"> <li>• Installation and use of any damaged appliance.</li> <li>• Modification of the appliance.</li> <li>• Installation other than as instructed by Hearth &amp; Home Technologies.</li> <li>• Installation and/or use of any component part not approved by Hearth &amp; Home Technologies.</li> <li>• Operating appliance without fully assembling all components.</li> <li>• Operating appliance without legs attached (if supplied with unit).</li> <li>• Do NOT Overfire - If appliance or chimney connector glows, you are overfiring.</li> </ul> <p>Any such action that may cause a fire hazard.</p>

Improper installation, adjustment, alteration, service or maintenance can cause injury or property damage. For assistance or additional information, consult a qualified installer, service agency or your dealer.



NOTE: Hearth & Home Technologies, manufacturer of this appliance, reserves the right to alter its products, their specifications and/or price without notice.

Quadra-Fire is a registered trademark of Hearth & Home Technologies.

# User Guide

## 2 Operating Instructions

### A. Over-Firing Your Appliance

 <b>WARNING</b>	
	<b>Fire Risk</b>
	Do not over-fire. Over-firing may ignite creosote or will damage the stove and chimney.
	To prevent over-firing your stove, DO NOT:
	<ul style="list-style-type: none"> <li>• Use flammable liquids</li> <li>• Overload with wood</li> <li>• Burn trash or large amounts of scrap lumber</li> <li>• Permit too much air to the fire</li> </ul>

#### 1. Symptoms of Over-Firing

Symptoms of over-firing may include one or more of the following:

- Chimney connector or appliance glowing
- Roaring, rumbling noises
- Loud cracking or banging sounds
- Metal warping
- Chimney fire

#### 2. What To Do if Your Stove is Over-Firing

- Immediately close the door and air controls to reduce air supply to the fire.
- If you suspect a chimney fire, call the fire department and evacuate your house.
- Contact your local chimney professional and have your stove and stove pipe inspected for any damage.
- Do not use your stove until the chimney professional informs you it is safe to do so.

Hearth & Home Technologies WILL NOT warranty stoves that exhibit evidence of over-firing. Evidence of over-firing includes, but is not limited to:

- Warped air tube
- Deteriorated refractory brick retainers
- Deteriorated baffle and other interior components

### B. Wood Selection & Storage

Burn only dry seasoned wood. Store wood under cover, out of the rain and snow. Dry and well-seasoned wood will not only minimize the chance of creosote formation, but will give you the most efficient fire. Even dry wood contains at least 15% moisture by weight, and should be burned hot enough to keep the chimney hot for as long as it takes to dry the wood out - about one hour. It is a waste of energy to burn unseasoned wood of any kind.

Dead wood lying on the forest floor should be considered wet, and requires full seasoning time. Standing dead wood can be considered to be about 2/3 seasoned. To tell if wood is dry enough to burn, check the ends of the logs. If there are cracks radiating in all directions from the center, it is dry. If your wood sizzles in the fire, even though the surface is dry, it may not be fully cured.

Splitting wood before it is stored reduces drying time. Wood should be stacked so that both ends of each piece are exposed to air, since more drying occurs through the cut ends than the sides. This is true even with wood that has been split. Store wood under cover, such as in a shed, or covered with a tarp, plastic, tar paper, sheets of scrap plywood, etc., as uncovered wood can absorb water from rain or snow, delaying the seasoning process.

### C. Burning Process

In recent years there has been an increasing concern about air quality. Much of the blame for poor air quality has been placed on the burning of wood for home heating. In order to improve the situation, we at Quadra-Fire have developed cleaner-burning wood stoves that surpass the requirements for emissions established by our governing agencies. These wood stoves, like any other appliances, must be properly operated in order to insure that they perform the way they are designed to perform. Improper operation can turn most any wood stove into a smoldering environmental hazard.

#### 1. Kindling or First Stage

It helps to know a little about the actual process of burning in order to understand what goes on inside a stove. The first stage of burning is called the kindling stage. In this stage, the wood is heated to a temperature high enough to evaporate the moisture which is present in all wood. The wood will reach the boiling point of water (212°F) and will not get any hotter until the water is evaporated. This process takes heat from the coals and tends to cool the appliance.

Fire requires three things to burn - fuel, air and heat. So, if heat is robbed from the appliance during the drying stage, the new load of wood has reduced the chances for a good clean burn. For this reason, it is always best to burn dry, seasoned firewood. When the wood isn't dry, you must open the air controls and burn at a high burn setting for a longer time to start it burning. The heat generated from the fire should be warming your home and establishing the flue draft, not evaporating the moisture out of wet, unseasoned wood, resulting in wasted heat.

#### 2. Second Stage

The next stage of burning, the secondary stage, is the period when the wood gives off flammable gases which burn above the fuel with bright flames. During this stage of burning it is very important that the flames be maintained and not allowed



to go out. This will ensure the cleanest possible fire. If the flames tend to go out, it is set too low for your burning conditions. The air control located at the upper right hand corner is used to adjust for burn rates. This is called the Burn Rate Air Control. **Figure 9.1**

**3. Final Stage**

The final stage of burning is the charcoal stage. This occurs when the flammable gases have been mostly burned and only charcoal remains. This is a naturally clean portion of the burn. The coals burn with hot blue flames.

It is very important to reload your appliance while enough lively hot coals remain in order to provide the amount of heat needed to dry and rekindle the next load of wood. It is best to open the Burn Rate Air and Start-Up Air Controls **before reloading**. This livens up the coalbed and reduces excessive emissions (opacity/smoke). Open door slowly so that ash or smoke does not exit appliance through opening. You should also break up any large chunks and distribute the coals so that the new wood is laid on hot coals.

Air quality is important to all of us, and if we choose to use wood to heat our homes we should do so responsibly. To do this we need to learn to burn our stoves in the cleanest way possible. Doing this will allow us to continue using our wood stoves for many years to come.

**D. Automatic Combustion Control (ACC)**

Typically, when you build a fire, you open the air controls fully and monitor the fire to prevent it from going into an overfire situation and/or burning your wood up too quickly before you shut down the air controls to the desired burn rate. With the Automatic Combustion Control (ACC) system, you do not have to continually monitor the fire. Once you set the ACC system it will control the fire for you. Follow the instructions below to learn how to operate your stove with ease.

**E. Air Controls**

Users will need to find their preferred setting between high and low based on desired heat output, installation configuration, and fuel type.

**1. Burn Rate Air Control**

This air supply enters at the upper front of the firebox, near the top of the glass door. This preheated air supplies the necessary fresh oxygen to mix with the unburned gases, helping to create second, third and fourth combustions. This air is regulated by the Burn Rate Air Control. When the control is moved all the way to the left it is on the High setting and when moved all the way to the right it is on the Low setting.

**Figure 9.1**

**2. Start-Up Air Control**



The Start-Up Air Control has two functions. The first is to engage the Automatic Combustion Control System (ACC). To engage the ACC timer system push the lever on bottom right corner of the unit in until it stops then pull out. The timer will slowly close in about 25 minutes. Use this feature

when reloading fuel or if you want more air supplied to the fire. The second function is to maximize heat output. To achieve a high burn push the ACC Air Control lever in and leave in. This combined with having the main burn rate control lever pushed to the left will deliver the most amount of air needed to achieve the highest amount of heat output.

**Figure 9.1**

**3. Manual Timer Over-Ride**

If you need to shut the ACC system off before it shuts itself off after 25 minutes (i.e. overfire situation), reach down to the bottom right and pull the lever toward you. **Figure 9.2**

 <b>CAUTION</b>	
	<b>Injury Risk.</b>
	<ul style="list-style-type: none"> <li>• Gloves recommended</li> </ul>

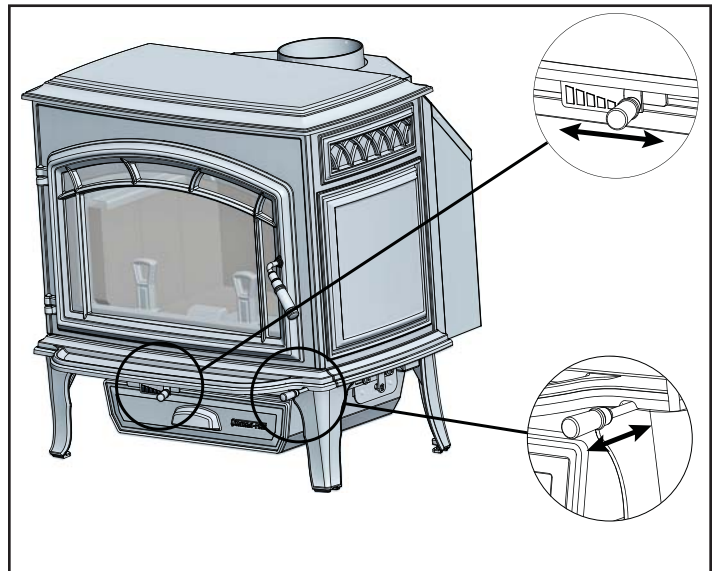

**Figure 9.1**

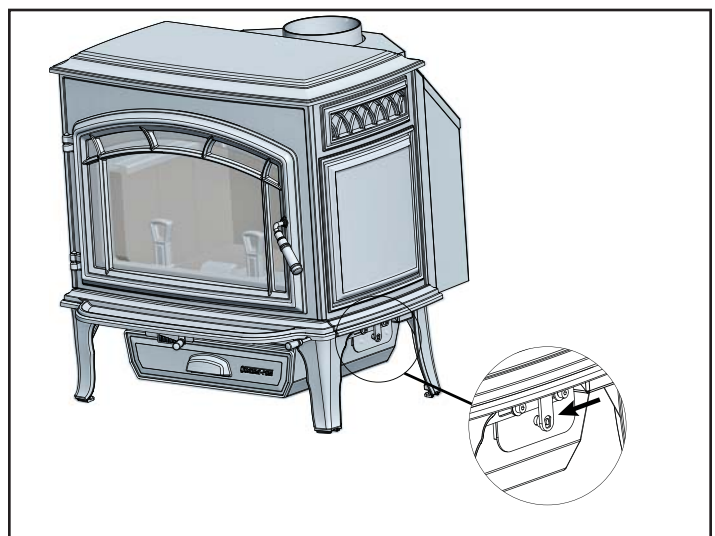

**Figure 9.2**

### F. Burn Rates and Operating Efficiency

#### For maximum operating efficiency

This wood heater has a manufacturer-set minimum low burn rate that must not be altered. It is against federal regulations to alter this setting or otherwise operate this wood heater in a manner inconsistent with operating instructions in this manual.

1. This appliance has a timer system (ACC) that operates the stove at its maximum efficiency removing any guess work for the homeowner. Follow the instructions below for each burn rate for the Start-Up Air Control and Burn Rate Air Control. **Figure 9.1**
2. Burn dry, well-seasoned wood.

#### **Burn Rates**

Primary control is open when moved to the left.

1. Low burn setting- Burn rate control on high for 5 min. Activate the boost/startup air, then close burn rate control to stop (move right)
2. Medium low burn setting- Burn rate control on high for 5 min, Activate the boost/startup air, then 1/8"-1/2" open (move left from low setting)
3. Medium high burn setting- Burn rate control on high. Activate the boost/startup air, 1/2 – full open (move left from low setting)
4. High burn setting: Burn rate control open (left) boost/startup open.

**Note:** 1-3 burn settings the fan shall be off for the first 30 minutes and then be operated in the high position at 30 minutes. High burn setting, fan shall be may continue to be on full after the loading of the fuel.

**NOTE:** Due to altitude and other circumstances this operation information is a guideline, units may run settings not in accordance with these guidelines to achieve same desired burn rates.

**NOTE:** Operate appliance on High Burn 45 minutes a day to help keep flue/chimney clean.



#### **WARNING**

##### **Risk of Fire.**



When set on High Burn Rate and over-riding the Automatic Combustion Control system an overfire situation can occur and may result in a chimney fire.

Overfiring will void the stove warranty.

### G. Building A Fire

Before lighting your first fire in the stove:

**NOTE:** The special high temperature paint that your stove is finished with will cure as your stove heats. You will notice an odor and perhaps see some vapor rise from the stove surface; this is normal. We recommend that you open a window until the odor dissipates and paint is cured.

1. Confirm the baffle is correctly positioned. It should be even with the front tube and resting on all tubes. **Figure 11.1 and 11.2 on page 11.**

2. Remove all labels from glass and inside of stove.

There are many ways to build a fire. The basic principle is to light easily-ignitable tinder or paper, which ignites the fast burning kindling, which in turn ignites the slow-burning firewood. Here is one method that works well:

1. Open the Burn Rate Air and Start-Up Air Controls fully.
2. Place several wads of crushed paper on the firebox floor. Heating the flue with slightly crumpled newspaper before adding kindling keeps smoke to a minimum.
3. Lay small dry sticks of kindling on top of the paper.
4. Make sure that no matches or other combustibles are in the immediate area of the appliance. Be sure the room is adequately ventilated and the flue unobstructed.
5. Light the paper in the appliance. NEVER light or rekindle fire with kerosene, gasoline, or charcoal lighter fluid; the results can be fatal.
6. Once the kindling is burning quickly, add several full-length logs 3 inches (76mm) or 4 inches (102mm) in diameter. Be careful not to smother the fire. Stack the pieces of wood carefully; near enough to keep each other hot, but far enough away from each other to allow adequate air flow between them.
7. Set the Burn Rate Air Control and activate the timer system (ACC).
8. When ready to reload, It is best to fully open both the Burn Rate Air and Start-up Air Controls **before reloading**. This livens up the coalbed and reduces excessive emissions (opacity/smoke). Open door slowly so that ash or smoke does not exit appliance through opening. Large logs burn slowly, holding a fire longer. Small logs burn fast and hot, giving quick heat.
9. As long as there are hot coals, repeating steps 6 through 8 will maintain a continuous fire throughout the season.

#### **NOTE:**

- Build fire on brick firebox floor.
- Do NOT use grates, andirons or other methods to support fuel. It will adversely affect emissions.



#### **WARNING**



##### **Fire Risk**

Do NOT store wood:

- Closer than required clearances to combustibles to appliance
- Within space required for loading or ash removal.

Do NOT operate appliance:

- With appliance door open.
- With ash removal system door open.

**WARNING**



**Fire Risk.**

- Do NOT burn wet or green wood.
  - Store wood in dry location.
  - Stack wood so both ends are exposed to air.
- Wet, unseasoned wood can cause accumulation of creosote.

**H. Correct Baffle & Blanket Placement**

**WARNING**



**Fire Risk**

Firebox damage due to improper baffle placement is not covered by warranty. Operate the wood burning appliance with the baffle in the correct position only.

Not doing so could result in:

- Reduced efficiency
- Overheating the chimney
- Overheating the rear of the firebox
- Poor performance

Ensure correct baffle placement and replace baffle components if damaged or missing.

**CAUTION**

The baffle boards are FRAGILE. Use extreme caution when loading firewood to prevent:

- Cracking, breaking or damaging the baffle boards

DO NOT operate the stove without baffle boards

**CORRECT POSITION**

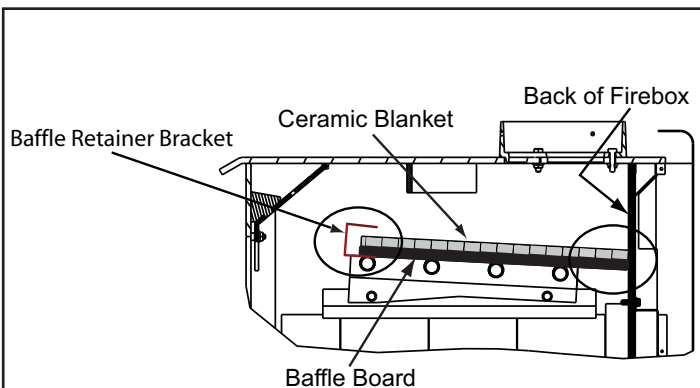

Ceramic Blanket and Baffle Board MUST be in contact with the back of the firebox and even with each other in the front.

Figure 11.1

**INCORRECT POSITIONS**

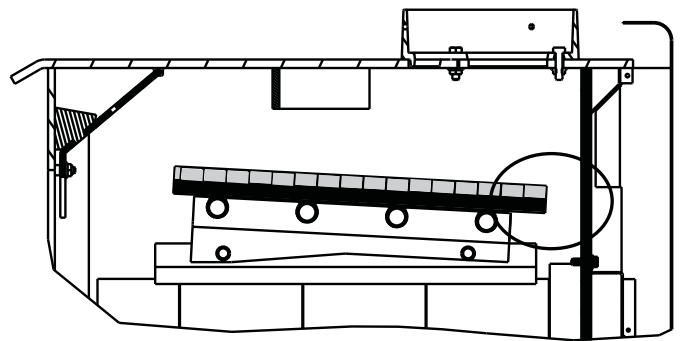

Ceramic Blanket and Baffle Board are NOT in contact with the back of the firebox.

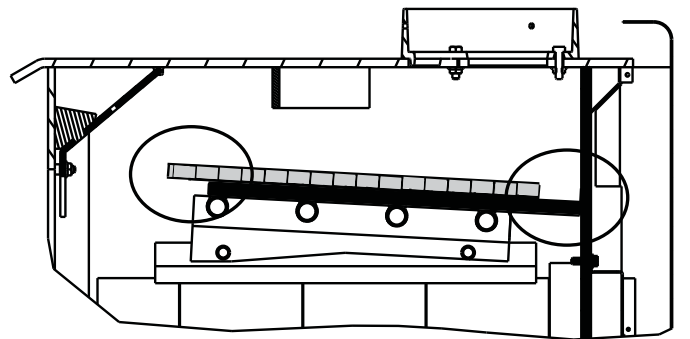

Ceramic Blanket is NOT in contact with the back of the firebox and NOT even with the Baffle Board in the front.

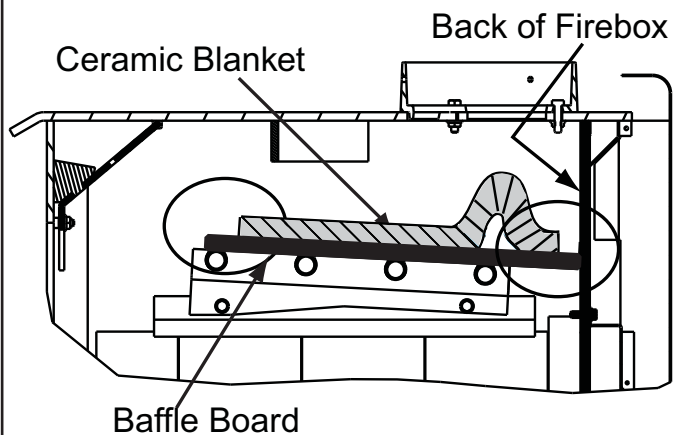

Ceramic Blanket is bunched up at the back of the firebox and NOT even with the Baffle Board in the front.

Figure 11.2

## I. Blower Operating Instructions

**NOTE:** If your Quadra-Fire wood stove is equipped with an optional blower, you should follow these guidelines:

### 1. Initial (cold) start-up and all Burn Settings

The blower can be plugged in and turned on right away. The blower fan is turned on and off by a snap disc. When your stove has reached a certain temperature the blower will turn on and when your stove has cooled down to a certain temperature it will turn off.

2. The blower is equipped with a speed control. Adjust the fan speed by turning the speed control clockwise to "Low" or counterclockwise to "High".

### 3. Snap Disc Location

If you find the blower coming on and off at undesirable temperatures, relocate the snap disc to another location in the designated zone on the back of the appliance.

**Figure 12.1** There is a manual over-ride switch to deactivate the snap disc, if necessary.

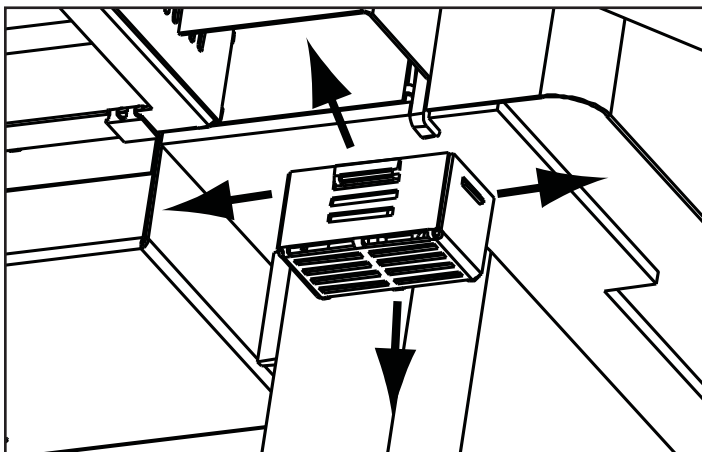

Figure 12.1

## J. Opacity (Smoke)

This is the measure of how cleanly your appliance is burning. Opacity is measured in percent; 100% opacity is when an object is totally obscured by the smoke column from a chimney, and 0% opacity means that no smoke column can be seen. As you become familiar with your appliance, you should periodically check the opacity. This will allow you to know how to burn as nearly smoke-free as possible (goal of 0% opacity).

### **WARNING**

#### **Fire Risk.**

- DO NOT BURN GARBAGE OR FLAMMABLE FLUIDS SUCH AS GASOLINE, NAPHTHA OR ENGINE OIL.
  - Do NOT burn treated wood or wood with salt (drift-wood).
  - May generate carbon monoxide if burn material other than wood.
- May result in illness or possible death.

### **WARNING**

#### **Fire Risk.**

- Keep combustible materials, gasoline and other flammable vapors and liquids clear of appliance.
- Combustible materials may ignite.
  - Do NOT store flammable materials in the appliance's vicinity.
  - DO NOT USE GASOLINE, LANTERN FUEL, KEROSENE, CHARCOAL LIGHTER FLUID OR SIMILAR LIQUIDS TO START OR "FRESHEN UP" A FIRE IN THIS HEATER.
  - Keep all such liquids well away from the heater while it is in use.



### **CAUTION**

When burning your first fire, you will experience smoke and odor from the appliance resulting from the curing of paint and burning off of any oils remaining from manufacturing.

**OPEN WINDOWS DURING INITIAL BURN TO DISSIPATE SMOKE AND ODORS!**

- Odors may be irritating to sensitive individuals.
- Smoke detectors may activate.

**K. Negative Pressure**

 <b>WARNING</b>	
	<p><b>Asphyxiation Risk.</b></p> <ul style="list-style-type: none"> <li>Negative pressure can cause spillage of combustion fumes, soot and carbon monoxide.</li> <li>Appliance needs to draft properly for safety.</li> </ul>

Negative pressure results from the imbalance of air available for the appliance to operate properly. It can be strongest in lower levels of the house.

Causes include:

- Exhaust fans (kitchen, bath, etc.)
- Range hoods
- Combustion air requirements for furnaces, water heaters and other combustion appliances
- Clothes dryers
- Location of return-air vents to furnace or air conditioning
- Imbalances of the HVAC air handling system
- Upper level air leaks such as:
  - Recessed lighting
  - Attic hatch
  - Duct leaks

To minimize the effects of negative air pressure:

- Install the outside air kit with the intake facing prevailing winds during the heating season
- Ensure adequate outdoor air for all combustion appliances and exhaust equipment
- Ensure furnace and air conditioning return vents are not located in the immediate vicinity of the appliance
- Avoid installing the appliance near doors, walkways or small isolated spaces
- Recessed lighting should be a “sealed can” design
- Attic hatches weather stripped or sealed
- Attic mounted duct work and air handler joints and seams taped or sealed

**L. Frequently Asked Questions**

ISSUES	SOLUTIONS
Odor from appliance	When first operated, this appliance may release an odor for the first several hours. This is caused by the curing of the paint and the burning off of any oils remaining from manufacturing.
Metallic noise	Noise is caused by metal expanding and contracting as it heats up and cools down, similar to the sound produced by a furnace or heating duct. This noise does not affect the operation or longevity of the appliance.
Whirring sound	If the optional blower has been installed, the blower produces a whirring sound which increases in volume as the speed is increased.

# 3 Maintenance and Service

## A. Quick Reference Maintenance Guide

When properly maintained, your fireplace will give you many years of trouble-free service. **Contact your dealer** to answer questions regarding proper operation, troubleshooting and service for your appliance. Visit [www.quadrafire.com](http://www.quadrafire.com) to locate a dealer. We recommend annual service by a qualified service technician.

**CAUTION!** Allow the appliance to completely cool down before performing any cleaning or maintenance.

Start the first inspection after the first 2 months of use, or if performance changes, and adjust your schedule accordingly. Maintenance is required for safe operation and must be performed to maintain your warranty.

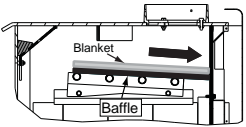
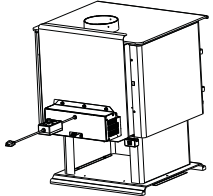
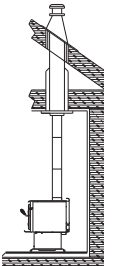
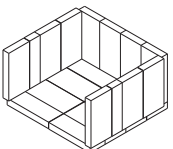
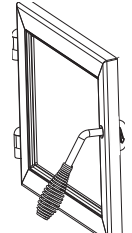
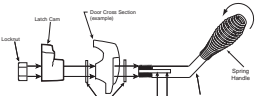
	Frequency	Task
<p><b>Baffle &amp; Blanket</b></p> 	<p>MONTHLY or After Every Cord of Wood</p>	<p>Baffle and blanket placement is critical to heat output, efficiency and overall life of the unit. Make sure the baffle is pushed all of the way to the back of the firebox and the blanket is laying flat. Inspect baffle for cracks.</p>
<p><b>Optional Blower</b></p> 	<p>YEARLY or After Every 4 Cords of Wood</p>	<p>Vacuum the blower impellers.</p>
<p><b>Chimney System</b></p> 	<p>EVERY 2 MONTHS or After Every 4 Cords of Wood</p>	<p>The chimney and chimney cap must be inspected for soot and creosote every two months during the burn season or more frequency if chimney exceeds or is under 14-16 ft (4.3m-4.8m) measured from bottom of appliance.</p> <p>This will prevent pipe blockage, poor draft, and chimney fires.</p> <p>Always burn dry wood to help prevent cap blockage and creosote build-up.</p>
<p><b>Firebrick &amp; Ash Removal</b></p> 	<p>WEEKLY or After Every 25 Loads of Wood</p>	<p>Ashes must be cool before you can dispose of the ashes in a non-combustible container.</p> <p>Firebrick is designed to protect your firebox. After ashes are removed, inspect the firebrick and replace firebricks that are crumbling, cracked or broken.</p>
<p><b>Door &amp; Glass Assemblies</b></p> 	<p>WEEKLY or After Every 25 Loads of Wood</p>	<p>Keep door and glass gasket in good shape to maintain good burn times on a low burn setting. To test: place a dollar bill between the stove and door and then shut the door. If you can pull the dollar out, remove one washer from door handle behind latch cam and try again. If you can still pull it out, replace the door gasket.</p> <p>Check the glass frame for loose screws to prevent air leakage. Check glass for cracks.</p>
<p><b>Door Handle</b></p> 	<p>WEEKLY or After Every 25 Loads of Wood</p>	<p>Check the door latch for proper adjustment. This is very important especially after the door rope has formed to the stove face.</p> <p>Check door handle for smooth cam operation.</p>

*These are generic drawings and may not represent your model.*

**B. General Maintenance**

**1. Creosote (Chimney) Cleaning**

- **Frequency:** Every 2 months during heating season or as recommended by a certified chimney sweep; more frequently if chimney exceeds or is under 14-16 ft. (measured from bottom of appliance)
- **By:** Certified Chimney Sweep

Remove all ash from the firebox and extinguish all hot embers before disposal. Allow the appliance to cool completely. Disconnect flue pipe or remove baffle and ceramic blanket from appliance before cleaning chimney. Otherwise residue can pile up on top of the baffle and ceramic blanket and the appliance will not work properly. (See Baffle Removal on page 19). Close the door tightly. The creosote or soot should be removed with a brush specifically designed for the type of chimney in use. Clean out fallen ashes from the firebox.

It is also recommended that before each heating season the entire system be professionally inspected, cleaned and repaired if necessary.

**Inspection:** Inspect the system at the appliance connection and at the chimney top. Cooler surfaces tend to build creosote deposits quicker, so it is important to check the chimney from the top as well as from the bottom.

**Formation and Need For Removal:** When wood is burned slowly, it produces tar and other organic vapors which combine with expelled moisture to form creosote.

The creosote vapors condense in the relatively cool chimney flue of a newly-started or a slow-burning fire. As a result, creosote residue accumulates on the flue lining. When ignited, this creosote creates an extremely hot fire which may damage the chimney or even destroy the house.

The chimney connector and chimney should be inspected once every 2 months during the heating season to determine if a creosote or soot buildup has occurred. If creosote or soot has accumulated, it should be removed to reduce the risk of a chimney fire.

**2. Ash Removal System (ARS) Operating and Cleaning**

- **Frequency:** As necessary
- **By:** Homeowner
  - a. The stove and ashes must be completely cooled down before using the Ash Removal System. Reach down and locate the ash removal door handle under the left side of the stove in the center. Grasp the handle with your fingers and place your thumb on the latch release (**Figure 15.1**). Press the latch release inward. Keep the latch release pressed in and lower the handle gently. Take your thumb off the release once the handle is clear of the latch and guide the handle back until it stops.
  - b. Remove cast iron cap from inside the firebox using tools supplied. Clean ash down through the ash removal system channel into the drawer below.

Inspect the top of the ARS door to ensure all ash has been removed. You can rapidly move the ARS latch handle up and down to help remove any ash from the door. Use a small brush to clean off the top of the door if any ash remains.

**Be sure to replace the cap before operating the stove.** It is recommended to leave 1/4 to 1/2 inch (6-13mm) of ash on the firebox floor to allow air to flow freely underneath wood.

- c. Close the door handle, you will hear a “click” when it closes. **Wear gloves to remove the drawer.** Dispose of the ashes following the directions on **the next page.**

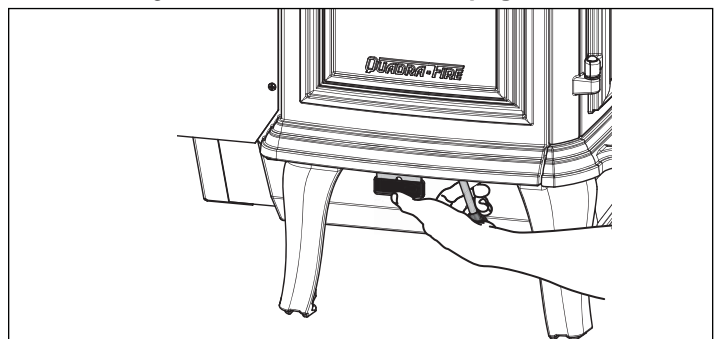







Figure 15.1

 <b>WARNING</b>	
	<b>Fire Risk.</b> Prevent creosote buildup.
	<ul style="list-style-type: none"> <li>• Inspect chimney connector and chimney once every two months during heating season.</li> <li>• Remove creosote to reduce risk of chimney fire.</li> <li>• Ignited creosote is extremely HOT.</li> </ul>

 <b>CAUTION</b>	
	<b>Injury Risk.</b>
	<ul style="list-style-type: none"> <li>• Gloves recommended</li> <li>• May have sharp edges</li> </ul>

 <b>WARNING</b>	
	<b>Fire Risk.</b>
	<ul style="list-style-type: none"> <li>• Do not use chimney cleaners or flame colorants in your appliance. Will corrode chimney pipe.</li> </ul>

 <b>WARNING</b>	
	<b>Fire Risk</b> <b>Injury Risk</b>
	<p>Make sure Ash Removal System door is sealed tight against the gasket.</p> <p>Air leakage may cause:</p> <ul style="list-style-type: none"> <li>• Over-fire condition.</li> <li>• Flame and/or smoke spillage.</li> <li>• Wood to burn too fast.</li> </ul>

## Explorer II Medium Wood Stove

---

### 3. Disposal of Ashes

- **Frequency:** When ash is within 1-3/4 in. (44mm) of firebox lip
- **By:** Homeowner

Ashes should be placed in a metal container with a tight fitting lid. The closed container of ashes should be placed on a non-combustible floor or on the ground, well away from all combustible materials, pending final disposal. If the ashes are disposed of by burial in soil or otherwise locally dispersed, they should be retained in the closed container until all cinders have thoroughly cooled.

#### **WARNING**



#### **Fire Risk.** **Disposal of Ashes**

- Ashes should be placed in metal container with tight fitting lid.
- Do not place metal container on combustible surface.
- Ashes should be retained in closed container until all cinders have thoroughly cooled.

### 4. Glass Cleaning

- **Frequency:** As desired
- **By:** Homeowner

Clean glass with a non-abrasive glass cleaner. Abrasive cleaners may scratch and cause glass to crack. If the deposits on the glass are not very heavy, normal glass cleaners work well. Heavier deposits may be removed by using a damp cloth dipped in wood ashes or by using a commercially available oven cleaner.

After using an oven cleaner, it is advisable to remove any residue with a glass cleaner or soap and water. Oven cleaner left on during the next firing can permanently stain the glass and damage the finish on metal surfaces.

A portion of the combustion air entering the firebox is deflected down over the inside of the door glass. This air flow “washes” the glass, helping to keep smoke from adhering to its surface.

When operated at a low burn rate, less air will be flowing over the glass and the smokey, relatively cool condition of a low fire will cause the glass to become coated.

Operating the appliance with the Burn Rate Air Control and Start-Up Air Control all the way open for 30-45 minutes should remove the built up coating.

#### **CAUTION**

- Do not use polishes with abrasives. It will scratch surfaces.



# 4 Troubleshooting Guide

With proper installation, operation, and maintenance your wood stove will provide years of trouble-free service. If you do experience a problem, this troubleshooting guide will assist you or a qualified service person in the diagnosis of a problem and the corrective action to be taken.

Start Fire Problems	Possible Cause	Solution
Can not get fire started Excessive smoke or spillage Burns too slowly Not enough heat output	Not enough kindling/paper or no kindling/paper	Use dry kindling, more paper. Arrange kindling & wood for air movement.
	Not enough air for fire to ignite	Check for restricted termination cap
		Check for blockage of outside air kit (if installed).
		Check for flue blockage.
		Pre-warm flue before starting fire (refer to Building a Fire Section).
		Check for adequate vent height (refer to Chimney Height Section).
		Refer to Negative Pressure section
	Wood condition is too wet, too large	Use dry, seasoned wood (refer to Seasoned Wood Section).
	Bed of coals not established before adding wood	Start with paper & kindling to establish bed of coals (refer to Building a Fire Section).
Flue blockage such as birds' nests or leaves in termination cap	Have chimney inspected for creosote and cleaned by a certified chimney sweep.	
Down draft or negative pressure Competition with exhaust devices	Do not use exhaust fans during start-up (refer to Negative Pressure Section).	
Fire burns too fast	Extremely dry or soft wood	Mix in hardwood.
		Mix in larger pieces of wood after fire is established.
	Overdrafting	Check for correct vent height; too much vertical height creates overdrafting.
		Check location of vent termination (refer to Chimney Termination Requirement Section).

**Contact your dealer** for additional information regarding operation and troubleshooting.  
 Visit [www.quadrafire.com](http://www.quadrafire.com) to locate a dealer.

# 5 Service Part Replacement

## A. Glass Replacement

1. Ensure that the fire is out and the appliance is cool to the touch.
2. Protect a table or counter top with padding or towels. Protect your hands and wear gloves to prevent injury.
3. Remove the door with the broken glass by lifting the door up and off of the hinges.
4. Lay door face down on a table or counter making sure the handle hangs over the edge so the door lays flat, on a soft surface.
5. Remove the screws from each glass retainer and remove the glass. (If screws are difficult to remove, soak with penetrating oil first).
6. Center the glass with edges evenly overlapping the opening in the door, (i.e. same space top and bottom, left and right sides).
7. Replace the glass retainers. Be careful not to cross thread the screws.
8. Tighten each retainer just a few turns until each is secured. Check again for centering of glass in door frame. Continue to tighten each retainer alternately, a few turns at a time, until the glass is secure. **DO NOT OVERTIGHTEN.**
9. Replace the door on the appliance.

Quadra-Fire stoves are equipped with ceramic super heat-resistant glass, which can only be broken by impact or misuse. Do not slam stove door or impact the glass. When closing door, make sure that logs do not protrude against the glass. Inspect glass regularly. If you find a crack or break, immediately put the fire out and return the door to your dealer for replacement of glass before further use.

**CAUTION**

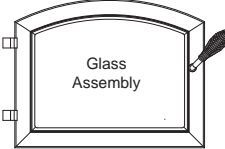



Handle glass assembly with care.

**When cleaning glass:**

- Avoid striking, scratching or slamming glass.

- Do NOT clean glass when hot.
- Do NOT use abrasive cleaners.
- Use a hard water deposit glass cleaner on white film.
- Use commercial oven cleaner on heavier deposits.
- Remove all residue of oven cleaner or will permanently stain glass on next firing. **Refer to maintenance instructions.**

 **WARNING**



**Injury Risk.**

- Use only glass specified in manual.
- **DO NOT REPLACE** with any other material.

## B. Firebrick Replacement

Replace the firebrick if they become crumbly and/or if there is a 1/4 inch (6.35mm) gap between the bricks.

Inspect the firebrick after each ash removal.

The firebox is lined with high quality firebrick, which has exceptional insulating properties. There is no need to use a grate; simply build a fire on the firebox floor. Do not operate appliance without firebrick.

1. After the coals have completely cooled, remove all old brick and ash from unit and vacuum firebox.
2. Remove new brick set from box and lay out to diagram shown.
3. Lay bottom bricks in unit.
4. Install rear bricks on the top of the bottom bricks. Slide top of bricks under clip on back of firebox wall and push bottom of brick back.
5. Install side bricks. Slide top of brick under clips on side of firebox and push the bottom of the brick until it is flush with the side of the appliance.

### C. Snap Disc Replacement

(included with optional blower)

1. Unplug the unit.
2. Locate the snap disc bracket assembly at the bottom left rear corner of the stove.
3. A magnet holds the bracket to the stove. Pull the bracket down away from the stove to expose the snap disc.
4. Pull the snap disc and spade connectors up and out of bracket as shown in **Figure 19.1**
5. Using a Phillips head screw driver, remove the 2 screws from the snap disc and then remove the snap disc from the spade connectors. Replace with new snap disc and re-connect to spade connectors.
6. Push the snap disc and spade connectors back inside bracket. Reassemble in reverse order.

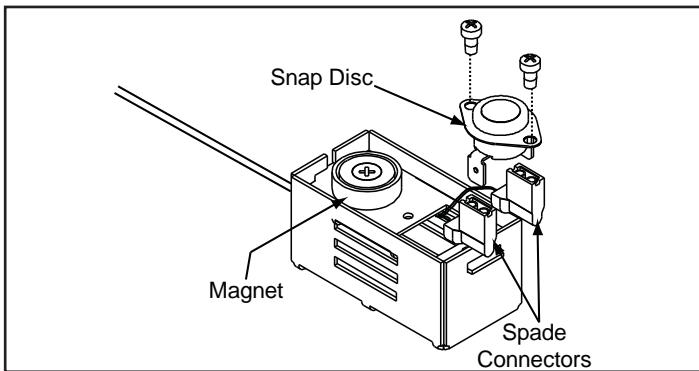

Figure 19.1

### D. Door Handle Assembly

1. Slide door handle through door.
2. Install additional washer(s) as shown in **Figure 19.2**
3. Install key in groove.
4. Align groove in latch cam with key; slide latch cam over shaft
5. Install locknut but do not overtighten, the handle needs to rotate smoothly.
6. Install fiber handle. **Figure 19.2**

**CAUTION!** Do not overtighten lock nut. The door handle needs to move smoothly.

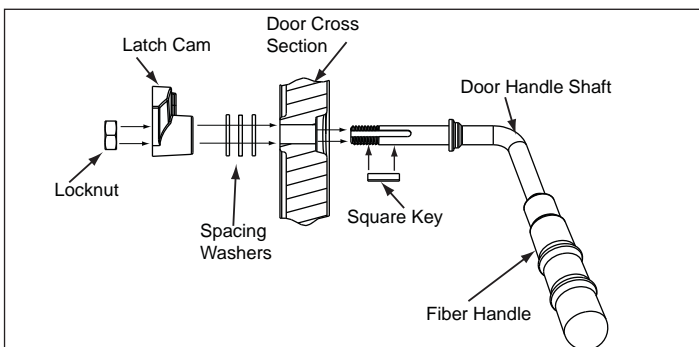

Figure 19.2

### E. Baffle Removal

**NOTE:** Tube Channel does not need to be removed to replace the baffles.

1. Remove all ash from the firebox, and extinguish all hot embers before disposal into a metal container.
2. The baffle board has 2 pieces. With the ceramic blanket still in place, slide one baffle piece over the top of other one and pull out top piece through the door opening and then remove bottom baffle piece. **Figure 19.3**
3. Remove the ceramic blanket.
4. Re-install the baffle pieces one piece at a time. Be sure the baffle boards are even with the front manifold tube and is resting on all tubes. **See page 11**
5. To re-install the ceramic blanket, it is easier to fold it in half first. Place on top of baffle board, open up and flatten and smooth out the blanket. Re-check the baffle board for correct positioning. **Figure 19.4**

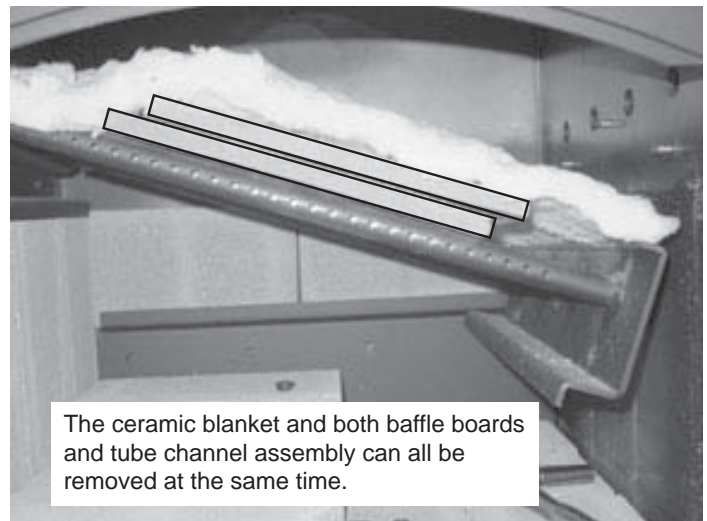

Figure 19.3

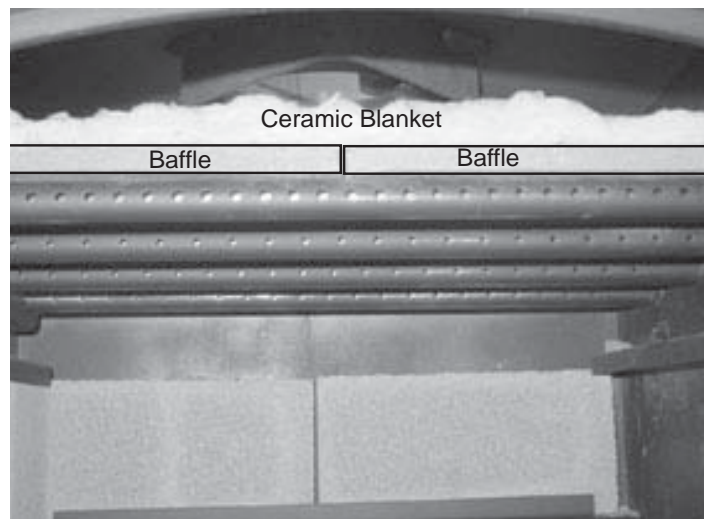

Figure 19.4

## Explorer II Medium Wood Stove

### F. Tube Channel Assembly Replacement

#### Removing Tube Channel Assembly

1. Remove the 3 right side bricks.
2. Remove the baffle protection channel by bending back the tabs using needle nose pliers located at the right and left side of the protection cover. Lift the cover up slightly and pull toward the front and out of the firebox. **Figure 20.1**

**NOTE:** Soak the bolts with penetrating oil for at least 15 minutes before trying to remove them.

3. Remove the 2 channel nuts (7/16) and 2 bolts (3/8) inside of chamber. **Figure 20.2**
4. Slide the tube channel assembly all the way to left until it is off the threads. Drop the right side down, then slide the assembly back to right. **Figure 20.3**
5. The ceramic blanket and both baffle boards can be removed at the same time you remove the tube channel assembly.
6. When the tube channel assembly is free of the left side support, rotate clockwise and pull assembly, blanket and baffles out through the front opening.
7. Re-install in reverse order.

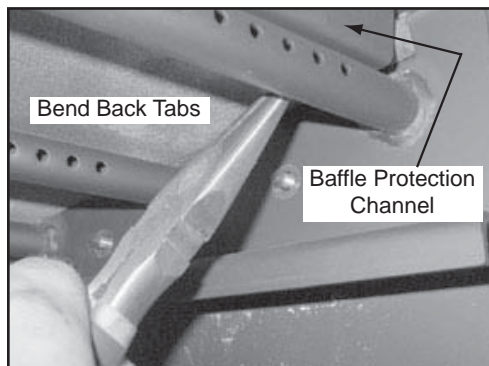

Figure 20.1

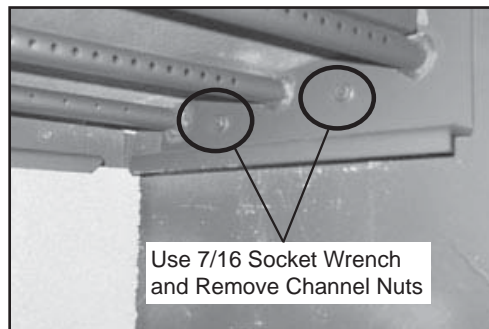

Figure 20.2

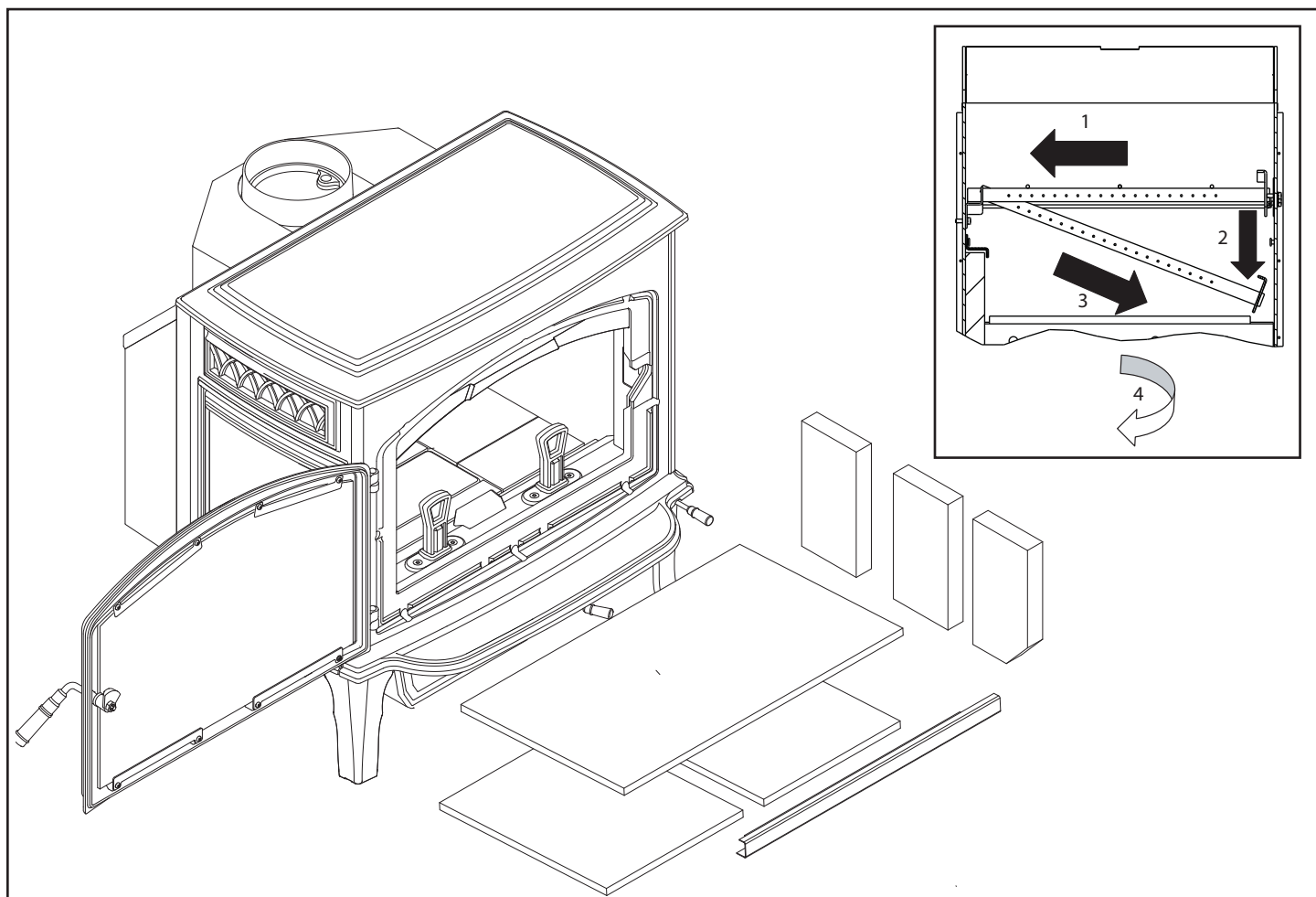

Figure 20.3



B. Service Parts & Accessories

**QUADRA-FIRE**® Service Parts  
Wood Stove

**Explorer II**

Beginning Manufacturing Date: March 2014  
Ending Manufacturing Date: Active

Color	SKU No.	Mfg. Dates
Matte Black	EXPLRMED-MBK	03/14-
Porcelain Black	EXPLRMED-PBK	10/14-
Porcelain Dark Blue	EXPLRMED-PDB	10/14-
Porcelain Frost	EXPLRMED-PFT	10/14-
Porcelain Mahogany	EXPLRMED-PMH	03/14-

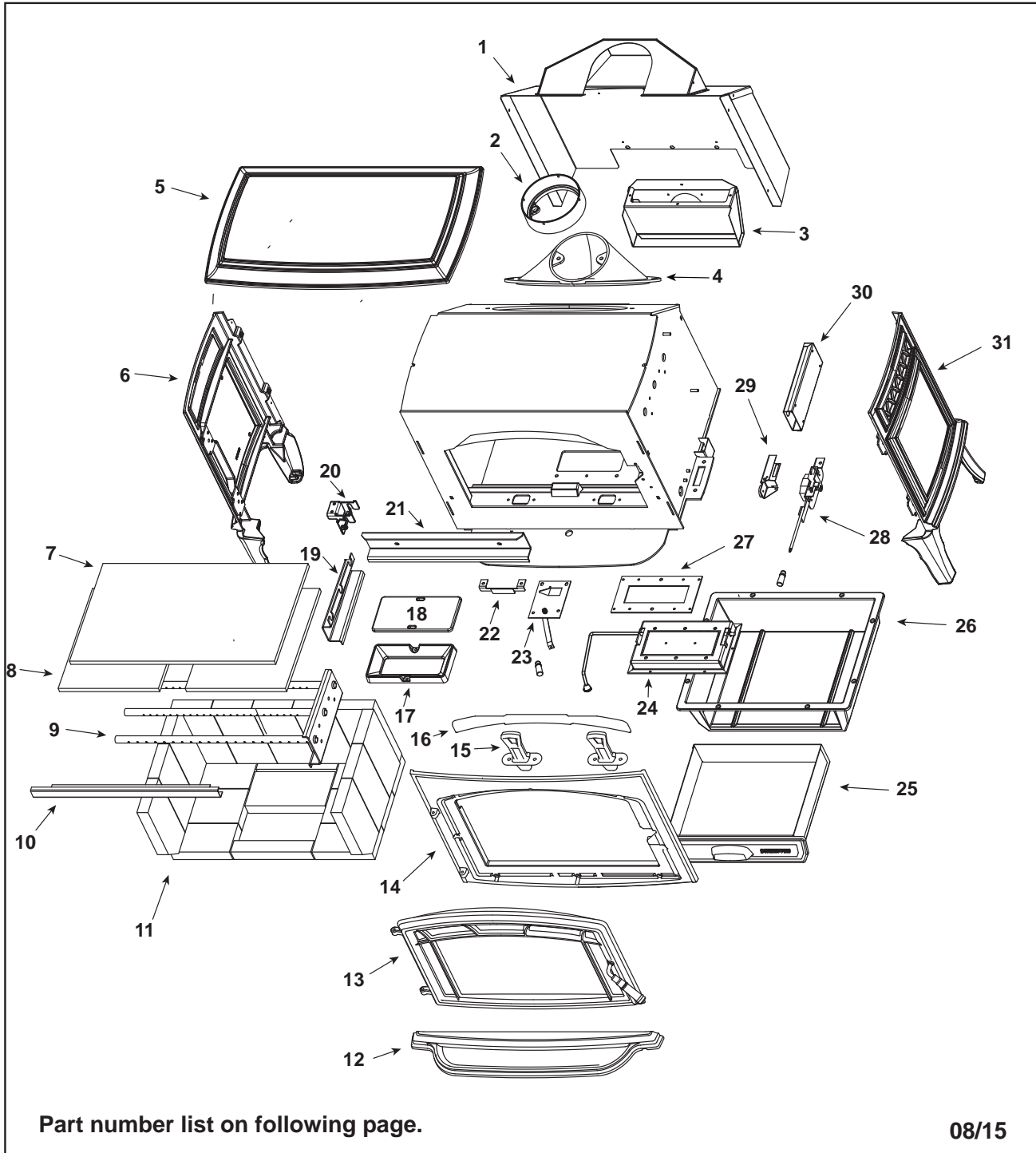

Beginning Manufacturing Date: March 2014  
Ending Manufacturing Date: Active

IMPORTANT: THIS IS DATED INFORMATION. Parts must be ordered from a dealer or distributor. **Hearth and Home Technologies does not sell directly to consumers.** Provide model number and serial number when requesting service parts from your dealer or distributor.



Stocked at Depot

ITEM	DESCRIPTION	COMMENTS	PART NUMBER	
1	Rear Shroud Assembly		SRV7061-015	
2	Flue Collar		SRV7061-201	
3	Outside Air Chamber		SRV7061-014	
4	Flue Transition Assembly		SRV29138	
5	Top	Matte Black	7061-101MBK	
		Porcelain Black	7061-101PBK	
		Porcelain Dark Blue	7061-101PDB	
		Porcelain Frost	7061-101PFT	
		Porcelain Mahogany	7061-101PMH	
6	Side Left	Matte Black	7061-012MBK	
		Porcelain Black	7061-012PBK	
		Porcelain Dark Blue	7061-012PDB	
		Porcelain Frost	7061-012PFT	
		Porcelain Mahogany	7061-012PMH	
7	Baffle Blanket		SRV7061-161	Y
8	Baffle Board	Qty 2 req	SRV7061-160	Y
9	Tube Channel		SRV7061-017	Y

**#10 Baffle Protection Channel**

Front, looking into unit →

Side view

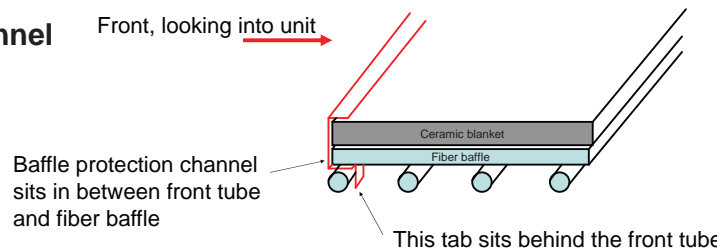

Baffle protection channel sits in between front tube and fiber baffle

10	Baffle Protection Channel		SRV7046-165	Y
----	---------------------------	--	-------------	---

**#11 Brick Assembly**

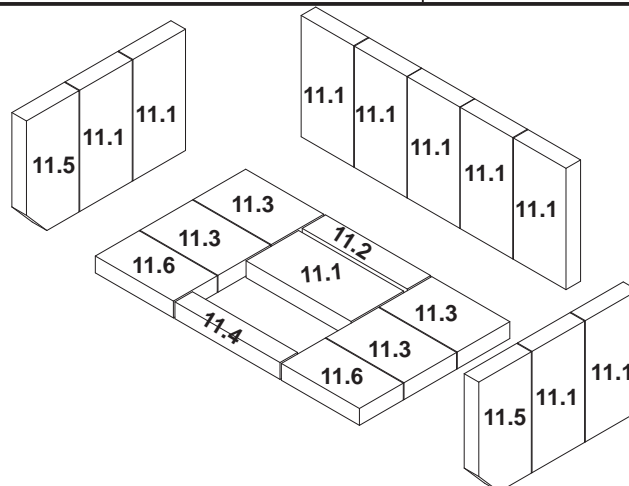

Additional service part numbers appear on following page.

IMPORTANT: THIS IS DATED INFORMATION. Parts must be ordered from a dealer or distributor. **Hearth and Home Technologies does not sell directly to consumers.** Provide model number and serial number when requesting service parts from your dealer or distributor.



**Stocked at Depot**

ITEM	DESCRIPTION	COMMENTS	PART NUMBER
11	Brick Assembly		SRV7061-004
11.1	Brick #1, 9 X 4.5 X 1.25	Qty 10 req	
11.2	Brick #2, 9 x 2 x 1.25	Qty 1 req	
11.3	Brick #3, 6.69 x 4.5 x 1.25	Qty 4 req	
11.4	Brick #4, 9 X 1.5 X 1.25	Qty 1 req	
11.5	Brick #5 w/angle, 9 X 4.5 X 1.25	Qty 2 req	
11.6	Brick #6, 6.69 X 3.5 X 1.25	Qty 2 req	
	Brick, Uncut (Must specify size when ordering)	Pkg of 1	832-0550
		Pkg of 6	832-3040
12	Ashlip	Matte Black	7061-113MBK
		Porcelain Black	7061-113PBK
		Porcelain Dark Blue	7061-113PDB
		Porcelain Frost	7061-113PFT
		Porcelain Mahogany	7061-113PMH

**#13 Door Assembly**

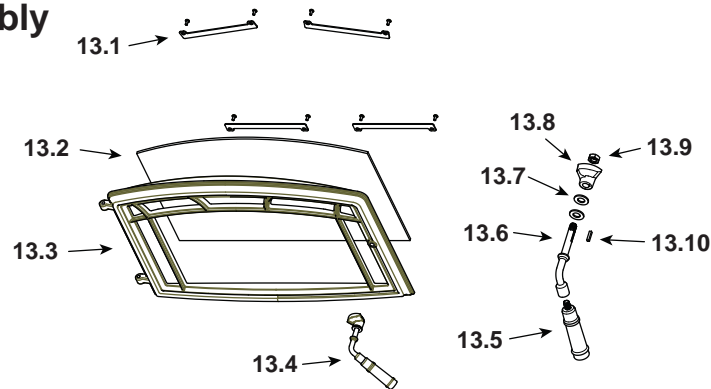

13	Door Assembly	Matte Black	7061-003MBK	
		Porcelain Black	7061-003PBK	
		Porcelain Dark Blue	7061-003PDB	
		Porcelain Frost	7061-003PFT	
		Porcelain Mahogany	7061-003PMH	
13.1	Glass Retainers		SRV7063-166	
13.2	Glass Assembly		SRV7061-013	Y
13.3	Door	Matte Black	7061-109MBK	
		Porcelain Black	7061-109PBK	
		Porcelain Dark Blue	7061-109PDB	
		Porcelain Frost	7061-109PFT	
		Porcelain Mahogany	7061-109PMH	
	Glass Gasket		834-1460	

Additional service part numbers appear on following page.



Beginning Manufacturing Date: March 2014  
Ending Manufacturing Date: Active

IMPORTANT: THIS IS DATED INFORMATION. Parts must be ordered from a dealer or distributor. **Hearth and Home Technologies does not sell directly to consumers.** Provide model number and serial number when requesting service parts from your dealer or distributor.



**Stocked at Depot**

ITEM	DESCRIPTION	COMMENTS	PART NUMBER	
13.4	Door Handle Assembly		SRV7063-014	Y
13.5	Fiber Handle		SRV7060-212	Y
13.6	Door Handle		SRV7063-137	
13.7	Washer, Sae, 3/8 (3 Ea)	Pkg of 3	832-0990	Y
13.8	Cam Latch		430-1141	
13.9	Nut, 2Wy Side Lock Jam 3	Pkg of 24	226-0100/24	Y
13.10	Key, Cam Latch		430-1151	
14	Front	Matte Black	7061-103MBK	
		Porcelain Black	7061-103PBK	
		Porcelain Dark Blue	7061-103PDB	
		Porcelain Frost	7061-103PFT	
		Porcelain Mahogany	7061-103	
	Gasket 7/16		844-3980	
15	Andirons	2 Sets	SRV7061-020	
16	Air Wash Bar		SRV7061-199	
17	ARS Channel		SRV7061-184	
18	ARS Access Cover		SRV7038-196	
19	Tube Rack		SRV7061-168	
20	ARS Latch Assembly		SRV7060-050	
21	Rear Brick Retainer		SRV7061-165	
22	Burn Rate Indicator		SRV7061-191	
23	Burn Rate Control		SRV7061-005	
24	ARS Door Assembly		SRV7060-048	
25	Ashpan		SRV7060-023	
26	ARS Box		SRV7060-005	
27	Gasket, ARS		SRV7033-296	Y
28	Timer Assembly		SRV7061-024	
	Timer (Only) Replacement Assembly		SRV480-1940	Y
29	Timer Door		SRV7061-018	
30	Tube Chanel cover		SRV7061-157	
31	Side Right	Matte Black	7061-011MBK	
		Porcelain Black	7061-011PBK	
		Porcelain Dark Blue	7061-011PDB	
		Porcelain Frost	7061-011PFT	
		Porcelain Mahogany	7061-011PMH	

Additional service part numbers appear on following page.

Beginning Manufacturing Date: March 2014  
Ending Manufacturing Date: Active

IMPORTANT: THIS IS DATED INFORMATION. Parts must be ordered from a dealer or distributor. **Hearth and Home Technologies does not sell directly to consumers.** Provide model number and serial number when requesting service parts from your dealer or distributor.



**Stocked at Depot**

ITEM	DESCRIPTION	COMMENTS	PART NUMBER	
	Component Pack (Includes Baffle Diverter and Instructions, 2 Leg Leveling Nuts & 2 Bolts, Touch-Up Paint, Owners Manual & Warranty Card)	Matte Black	SRV7061-027	
		Porcelain Black	SRV7061-031	
		Porcelain Dark Blue	SRV7061-032	
		Porcelain Frost	SRV7061-033	
		Porcelain Mahogany	SRV7061-028	
	Leveling Assembly		7000-000	
	Paint Touch-Up	Matte Black	812-0910	
		Porcelain Black	1-00-0022	
		Porcelain Dark Blue	1-00-0020	
		Porcelain Frost	1-00-0021	
		Porcelain Mahogany	855-1450	
<b>ACCESSORIES</b>				
	Blower Assembly		BK-ACC	
	Blower Control Box W/Switch		SRV7000-194	Y
	Component Pack		7033-051	
	Magnet Round		SRV7000-140	Y
	Snap Disc Bracket Assembly		7033-036	
	Snap Disc, # 1, Convection Blower		SRV230-0470	Y
	Speed Control Only (Rheostat)		842-0370	Y
	Wire Harness (Blower)		7033-262	
	Blower, Convection	Blower Only	812-4900	Y
	Outside Air Kit, Floor & Rear		OAK-ACC	
	Outside Air Collar Assembly		7033-039	
	Outside Air Shield		33271	Y
	Firescreen		SCR-7061	
<b>FASTENERS</b>				
	Avk Rivnut Repair Kit - 1/4-20 & 3/8-16 Rivnut Tools		RIVNUT-REPAIR	Y
	Nut, Ser Flange Small 1/4-20	Pkg of 24	226-0130/24	Y
	Screw, Pan Head Philips 8-32 X 3/8	Pkg of 40	225-0500/40	Y
	Screw, Sheet Metal #8 X 1/2 S-Grip	Pkg of 40	12460/40	Y
	Washer, 1/4 Sae	Pkg of 24	28758/24	Y



# QUADRA-FIRE®

NOTHING BURNS LIKE A QUAD

## CONTACT INFORMATION

Hearth & Home Technologies  
1445 North Highway  
Colville, WA 99114  
Division of HNI INDUSTRIES

Please contact your Quadra-Fire dealer with any questions or concerns.  
For the number of your nearest Quadra-Fire dealer  
log onto [www.quadrafire.com](http://www.quadrafire.com)

### CAUTION



#### DO NOT DISCARD THIS MANUAL

- Important operating and maintenance instructions included.
- Read, understand and follow these instructions for safe installation and operation.
- Leave this manual with party responsible for use and operation.

DO NOT  
DISCARD

**We recommend that you record the following pertinent information for your heating appliance.**

Date purchased/installed: \_\_\_\_\_

Serial Number: \_\_\_\_\_ Location on appliance: \_\_\_\_\_

Dealership purchased from: \_\_\_\_\_ Dealer phone: \_\_\_\_\_

Notes: \_\_\_\_\_

---

---

---

This product may be covered by one or more of the following patents: (United States) 5341794, 5263471, 6688302, 7216645, 7047962 or other U.S. and foreign patents pending.