

SHR33 / SHR40

Appliance Specifications - Shoreline™ Direct Vent Fireplace Inserts

| Insert Dimensions | | Inches (millimeters) |
|-------------------|--------------------------------------|----------------------|
| A | Left front of unit to center line | 13-1/8 (333) |
| B | Right front of unit to center line | 17-1/4 (438) |
| C | Left rear of unit to center line | 9 (229) |
| D | Right Rear Of Unit To Center Line | 7-5/8 (194) |
| E | Center Of Air Intake To Center Line | 6-3/4 (172) |
| F | Center Of Flue To Center Line | 2 (51) |
| G | Insert Depth Into Fireplace | 15-3/8 (391) |
| H | Air Intake Center From Front | 12-7/8 (327) |
| I | Flue Center From Front Of Unit | 14 (356) |
| J | Front Of Unit To Back Of Flue Collar | 15-1/8 (384) |
| K | Unit Height At Front | 22-3/8 (568) |
| L | Base Of Unit To Top Of Flue Collar | 21 (533) |
| M | Base Of Unit To Intake Collar | 7-7/8 (200) |
| N | O.D. Width, Small, 3-pc Flange | 36-5/8 (930) |
| N | O.D. Width, Large, 3-pc Flange | 41 (1041) |
| O | O.D. Height, Small, 3-pc Flange | 25-7/8 (657) |
| O | O.D. Height, Large, 3-pc Flange | 28 (711) |
| P | O.D. Width, Small, 4-pc Flange | 36-5/8 (930) |
| P | O.D. Width, Large, 4-pc Flange | 41 (1041) |
| Q | O.D. Height, Small, 4-pc Flange | 29-3/16 (741) |
| Q | O.D. Height, Large, 4-pc Flange | 33-1/2 (851) |
| R | Glass Viewing Height | 16-7/8 (429) |
| S | Glass Viewing Width | 26-5/8 (676) |

| Rear Insert Dimensions - Inches (millimeters) | |
|---|--------------|
| Rear width of unit | 16-5/8 (422) |
| Front Width of unit | 30-3/8 (772) |
| Depth of unit (excluding Surround Kit) | 15-3/8 (391) |

Note: Due to Lennox' ongoing commitment to quality, all specifications, ratings and dimensions are subject to change without notice.

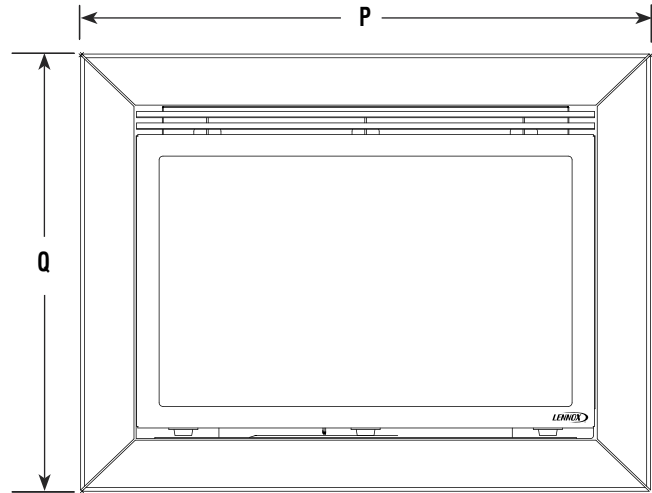

4-Sided Surround Kit

Front View

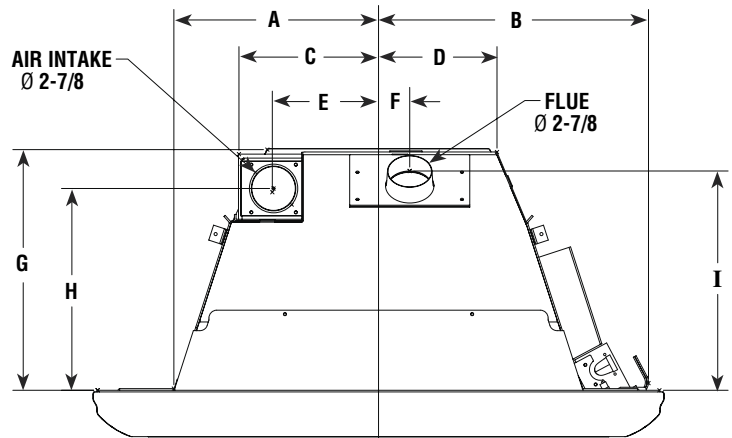

Top View Center

Fireplace Insert Dimensions

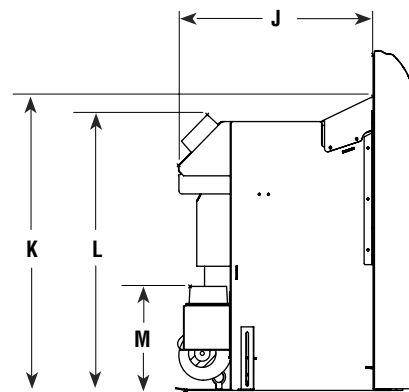

Side View

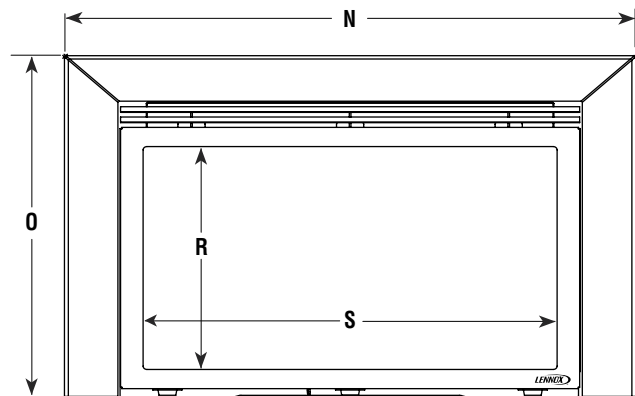

3-Sided Surround Kit

Front View

SHR33 / SHR40

Tested & Listed By **OTL** Beaverton Oregon USA
OMNI-Test Laboratories, Inc.
 Report No. 050-F-22-5

These appliances comply with National Safety Standards and are tested and listed by OMNI-Test Laboratories Inc.; Beaverton, Oregon (Report No. 050-F-22-5) to ANSI Z21.88-2005/CSA 2.33-2005, and CGA 2.17-M91 in both USA and Canada, as Vented Gas Fireplace Heaters and are approved for installation in bedrooms and manufactured (mobile) homes.

Typical Installation

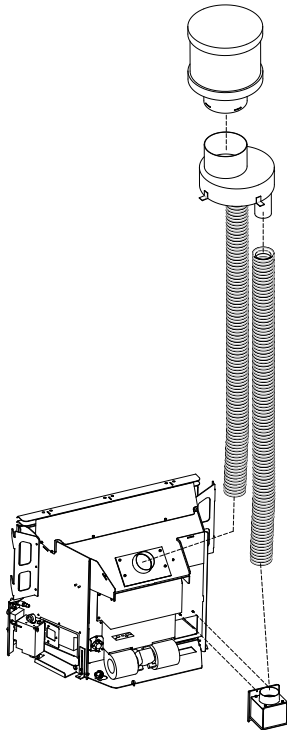

Listing Information

| | Natural Gas | Propane (LP) Gas |
|--------------|----------------------------|----------------------------|
| Model | Input Rate (BTU/HR) | Input Rate (BTU/HR) |
| SHR33 | 19,500 to 33,000 | 19,500 to 33,000 |
| SHR40 | 24,000-40,000 | 21,500 to 37,500 |

| Efficiencies % | | | | | | |
|----------------|--------------|---------------|-----------|--------------|---------------|-----------|
| Models | Natural Gas | | | Propane | | |
| | P4** | Steady State* | AFUE | P4** | Steady State* | AFUE |
| SHR33 | 60.91 | 83 | 60 | 64.35 | 83 | 65 |
| SHR40 | 62.70 | 83 | 63 | 65.98 | 83 | 67 |

* The Steady State Efficiency numbers based on maximum vent configuration.

** Tested to CSA P.4.1-02 "Testing Method for Measuring Annual Fireplace Efficiency."

Clearances

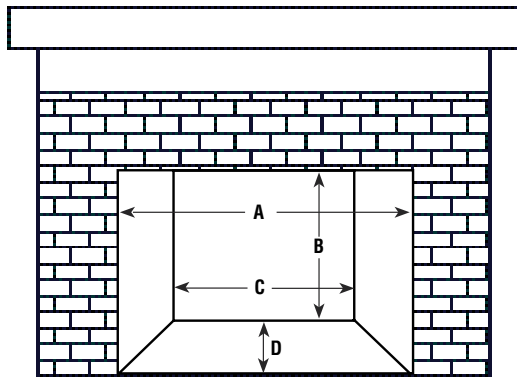

Minimum Size of Existing Fireplace Firebox

| G | H |
|----------------------------------|----|
| H dimension determines G minimum | |
| 0" | 8" |
| 1-1/2" | 7" |
| 3" | 6" |
| 4-1/2" | 5" |
| 6" | 4" |
| 7-1/2" | 3" |
| 9" | 2" |
| 10-1/2" | 1" |
| 12" | 0" |

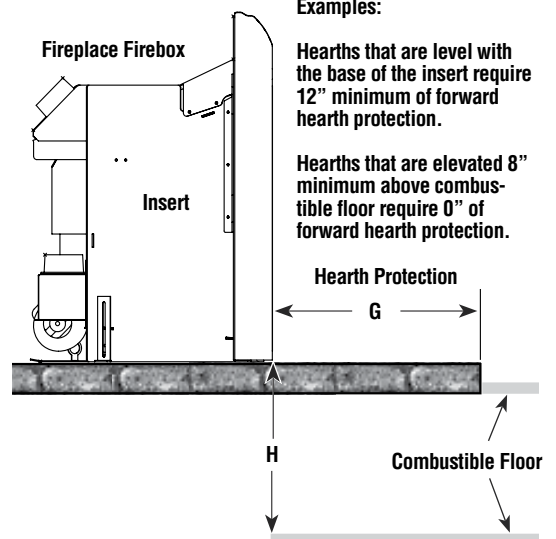

Examples:

Hearths that are level with the base of the insert require 12" minimum of forward hearth protection.

Hearths that are elevated 8" minimum above combustible floor require 0" of forward hearth protection.

Hearth Protection

Combustible Floor

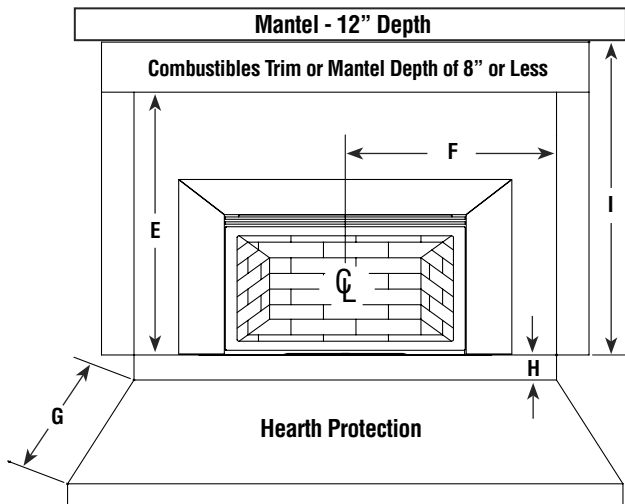

| | Minimum Fireplace Dimensions and Minimum Clearances | Inches (millimeters) |
|----------|---|----------------------|
| A | Minimum front opening required | 36 (914) |
| B | Minimum height required | 21-1/2 (546) |
| C | Minimum rear width required | 19-1/2 (495) |
| D | Minimum fireplace depth required | 16 (406) |
| E | Clearance needed from bottom of insert to combustibles or 8" mantel | 35 (889) |
| F | Clearance required from center of glass to combustible material | 30 (762) |
| G | Minimum inches of hearth protection needed from front of unit | 12 (305) |
| H | Vertical clearance needed under the bottom of the insert for NO hearth protection | 8 (203) |
| I | Clearance needed from bottom of insert to 12" mantel | 38 (965) |