



LENNOX HEARTH PRODUCTS

HOMEOWNER'S CARE AND OPERATION INSTRUCTIONS

MAGNA-FIRE

43" Wood Burning Fireplace
P/N 875,004M REV. E 10/2006

MODELS

LS43ST

The information contained in this manual applies to all model fireplaces identified on this page. This information will help you obtain safe and dependable service from your fireplace system. Keep this document in a safe place for future reference.

Before you start your first fire, read this Care and Operations Manual carefully to be sure you understand your fireplace system completely. Failure to follow these suggestions could result in hazardous operation or fireplace malfunction, creating a serious potential for personal injury and/or property damage.

If you have any questions regarding the safe use or operation of your fireplace, contact your local distributor or your contractor/builder.

Most chimney systems will require onsite completion after placement of the manufactured home.

**RETAIN THESE INSTRUCTIONS
FOR FUTURE REFERENCE**



OMNI-Test Laboratories, Inc.

OTL Report No. 116-F-19-02

CONGRATULATIONS!

In selecting this DAVE LENNOX Signature™ Collection wood burning see-through fireplace, you have chosen the finest and most dependable fireplace to be found anywhere. A beautiful, prestigious, addition to the finest homes. Welcome to a Family of hundreds of thousands of satisfied LENNOX Fireplace Owners.

Please read and carefully follow all of the instructions found in this manual. Please pay special attention to the safety instructions provided in this manual. The Homeowner's Care and Operation Instructions included here will assure that you have many years of dependable and enjoyable service from your LENNOX product.

TABLE OF CONTENTS

Safety precautions	page 2
General information	page 2
Fuels	page 2
Decorative gas log sets	page 2
Disposal of ashes	page 3
Softwood vs hardwood	page 3
Starting a fire	page 4
Glass doors	page 4
Combustion Air	page 4
Refractories	page 5
Maintenance Guidelines	page 5
Twice a year check-up	page 6
Creosote Formation and Removal	page 6
Trouble shooting	page 6
Accessories & Components	page 7
Replacement Parts List	page 7
Replacement Parts	page 8

GENERAL SAFETY PRECAUTIONS IMPORTANT! READ AND UNDER- STAND BEFORE YOUR FIRST FIRE.

1. Use SOLID WOOD only for fuel. It is best to use dry and well seasoned hardwood. Soft woods tend to burn very quickly. DO NOT use treated wood, charcoal, coal, trash, driftwood or woods that have been dipped in tar, pitch, pine tar, creosote, etc. Wood products made with synthetic binders, such as plywood, produce abnormally high temperatures and sputtering, smoking fires. When burning artificial logs, please read and follow the instructions provided by the manufacturer.

Never burn treated construction lumber or scraps. These woods burn excessively hot and may contain chemicals used to treat insects and fungus. When burned, these chemicals can pose a significant hazard.

2. Keep the chimney damper open while any fire or smoldering embers are present .

3. NEVER use gasoline, gasoline-type lantern fuel, kerosene, charcoal lighter fluid, or similar liquids to start or "freshen up" a fire in this fireplace. Keep any flammable liquids a safe distance from the fireplace.

4. With the fire burning, close the protective mesh screens to keep sparks and embers INSIDE the firebox.

5. Keep any combustible furniture or decorative pillows at least 36" (914 mm) from the fireplace opening.

6. Never leave your fireplace unattended while it is burning.

7. Be careful adding wood fuel to the fire or handling fireplace tools such as shovels, tongs or pokers.

8. Never modify or alter your fireplace system in any way. To do so may create a potential fire hazard and void the Limited Warranty.

9. The bottom refractory can be cracked by excessive abuse such as tossing heavy logs onto the grate or gouging with fireplace tools. Exercise caution when adding wood to your fireplace.

10. DO NOT use a fireplace insert or any other product not specified by the manufacturer for use with this fireplace.

11. If you are using your fireplace as a "decorative appliance", such as with a permanently installed gas log set, the fireplace damper must be permanently fixed in the open position. This includes unlisted "vent-free" gas log sets. Listed "vent-free" log sets may be operated with the damper clamped closed.

12. Always ensure that an adequate supply of replacement combustion air from the outside of the house is accessible to the fire to support normal combustion. Fireplaces consume large volumes of air during the normal combustion process. In the event the home is tightly sealed with modern energy efficient features, an optional combustion air kit may not provide all the air required to support combustion.

The manufacturer is not responsible for any smoking or related problems that may result from the lack of adequate combustion air. It is the responsibility of the builder/contractor to ensure that adequate combustion air has been provided for the fireplace.

13. The manufacturer does not warranty "smoke free" operation nor are we responsible for inadequate system draft caused by mechanical systems, general construction conditions, inadequate chimney heights, adverse wind conditions and/or unusual environmental factors or conditions beyond our control.

GENERAL INFORMATION

1. The all-steel, multi-wall firebox is the heat center of the system. It is well insulated for safe clearance to combustibles.

2. The hearth floor and sides of the firebox is a brick pattern reinforced refractory base for your fire.

3. The metal chimney sections extending from the firebox top to beyond your roof are two walled and air-cooled. The inner passage, or flue, provides the exit for smoke and gases.

4. The flue damper is either fully open or fully closed by the handle you find in the center and top of the firebox. It must be open when fire is present so smoke and gases can escape. It should be closed only when the fire is completely out – keeping room air from being lost up the flue.

5. Closed screens prevent fire, sparks and embers from popping out of the firebox while a fire is burning. Pull screens back when adding wood to the firebox.

6. Why use a fuel grate? Besides positioning the firebed properly, it protects the refractory floor, back and sides of the fireplace. Further, it ensures a proper flow of combustion air into and around the firebed. The grate must be used at all times when burning. Your warranty may be voided without the use of this grate.

7. Remember, your fireplace is not intended to heat your entire home. Their unique designs are intended for architectural, decorating and aesthetic considerations.

FUELS

Never Use Coal in Your Fireplace

Your fireplace system is not designed to be used with coal derivative products. The combustion process of certain types of coal can deposit corrosive materials in the fireplace and chimney system which can lead to premature product failure. Never use coal as a fuel in this fireplace system.

Decorative Gas Log Sets

If your fireplace system was installed with a gas line and you wish to install a decorative gas appliance (gas log set), it must contain an automatic shut-off device complying with the Standard for Decorative Gas Appliances for installation in vented fireplaces, ANSI Z21.60 (1991) or American Gas Association draft requirements for Gas-Fired Log Lighters for Wood Burning Fireplaces, Draft No. 4 dated August, 1993. Install in accordance with the National Fuel Gas Code, ANSI Z223.1. This complies with the revised U.L. 127 standard.

Vent Free Appliances

These units have been tested and approved to ANSI/IAS/AGA Z21.11.2 for use with unvented gas appliances and complies with the standard for Factory-Built fireplaces, UL 127.

The unit has been tested for use with any unvented gas log sets having a maximum rating of 40,000 BTU.

These fireplaces have been marked with a maximum rating of 40,000 BTU to assure that homeowners do not exceed the allowable limits for all allowed installations of mantles.

NEVER INSTALL AN UNVENTED GAS LOG SET WITH A BTU GREATER THAN 40,000.

CAUTION: WHEN USING A VENTED DECORATIVE GAS APPLIANCE, THE FIREPLACE DAMPER MUST BE SET IN THE FULLY OPEN POSITION.

Wood Fuel Pointers

Wood is a wonderful renewable fuel source. Normally it burns clean, leaving only a minimum of waste ash, provides comforting heat and can provide a variety of aromas and visual images.

You will want to know which woods are best for use. Sometimes you may want a quick, short fire to offset a morning chill. Soft woods are preferable in this case. Other times you would want more slow burning and a uniform heat output. Hardwoods are preferable for this use.

The amount of heat available from the logs will be about equal on a weight basis. However, logs are generally not weighed so the amount of heat will depend on: the type of wood used, how dry the wood is, how many logs you put in and the size of the logs.

The last statement means that one big log weighing 10 pounds has as much heating potential as 10 pounds of twigs. However, air cannot get at the solid log to feed the fire so the solid log will burn slowly.

While you would get the same amount of heat out of either fire, the smaller the pieces of wood and the more air space around them, the faster the fire will burn.

If process solid fuel firelogs are used, DO NOT poke or stir the logs while they are burning. Use only firelogs that have been evaluated for the application in fireplace and refer to the firelog warnings and caution markings on the packaging prior to use.

Disposal of Ashes

Ashes should be placed in a metal container with a tight fitting lid. The closed container of ashes should be placed on a non-combustible floor or on the ground, well away from all combustible materials, pending final disposal. If the ashes are to be disposed of by burial in soil or other wise locally dispersed, they should be retained in the closed container until all cinders have thoroughly cooled.

Softwood vs Hardwood

Softwoods contain about 15 percent highly flammable resin which generates creosote soot in the chimney flue. Burning softwood exclusively may not be as desirable nor as safe as burning denser hardwoods. Many experienced fire-builders use small amounts of softwood kindling and newspaper in conjunction with starting a fire with split hardwood logs. Here are some guidelines to remember:

1. Softwoods produce fast warming and shorter fires. Hardwoods burn less vigorously, have shorter flames and produce steady, glowing coals.
2. As a general rule, denser woods contain more potential heat per pound. Most softwoods offer moderate heat value per pound.
3. Different woods vary widely in flame heights, flame intensities, smoke characteristics and in sparking. Most hardwoods do not spark.
4. Most freshly cut "green" wood will not burn well and will smoke. Green wood can be from 10 to 40 percent less efficient than air-dried seasoned wood.
5. Moisture and resin found inside unseasoned wood cells will build up pressure under heat and explode as sparks.
6. Most wood needs to be seasoned 9 to 12 months to reduce the moisture content and produce good steady fires. When moisture content is reduced from 60 to 20%, the gain in heat potential is nearly 7%.

7. Proper storage of wood, especially during seasoning, is essential. We recommend that you:

- a. Never store wood on the ground. This will cause rotting and insect infiltration. Raise wood on flat rock or scrap wood.
- b. Stack wood loosely to allow air circulation.
- c. Store wood where it will not be excessively exposed to weather, such as under a tarp or under a roof.
- d. Do not stack wood directly against the walls of your home.

8. Be a knowledgeable wood buyer. There is a difference in cord sizes. A standard cord stack of logs is 4 ft. high by 8 ft. long by 4 ft. deep or the equivalent of this cubic footage. A face cord is the same height and length as a standard cord but the depth is only the length of the logs (12, 18 or 24 inches). A face cord can contain as little as 25% of the wood found in a standard cord.

If you buy by the ton, remember that wood becomes lighter as it dries. When buying green or wet wood, ask for some extra poundage to allow for the extra water you will be getting.

9. When comparing woods of the same moisture content and same species, we find most woods have approximately the same heating potential per pound. However, most wood is sold by volume, not by weight. To determine the best heating source, look at the density of various wood types. (Density is the weight for a given size.)

The higher the density, the more potential heat output. A standard cord has a volume of 128 cubic feet. This figure also includes the air space between and around the wood. The actual volume in a standard cord is between 60 and 100 cubic feet; depending on how tightly the wood is packed.

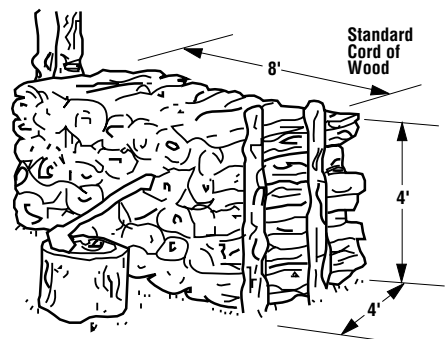

Figure 1

HARDWOODS	DENSITY
Alder, Red	.41
Ash	.49-.60
Aspen	.38-.39
Basswood, American	.37
Beech, American	.64
Birch	.55-.65
Butternut	.38
Cherry, Black	.50
Chestnut, American	.43
Cottonwood	.34-.40
Elm	.60.63
Hickory, Pecan	.60.66
Hickory, True	.69-.75
Magnolia	.48-.50
Maple	.48-.63
Oak, Red	.59-.67
Oak, White	.64-.88
Poplar	.42
Sassafras	.42
Sycamore, American	.49
Tanoak	.64 (est.)
Walnut, Black	.55
Willow, Black	.39
SOFTWOODS	DENSITY
Bald cypress	.46
Cedar	.31-.47
Douglas Fir	.46-.50
Fir	.32-.43
Hemlock	.40-.45
Pine	.39-.59
Redwood	.35-.40
Spruce	.35-.41

Assuming that you are comparing two standard cords of different species but the same volume and moisture content, the denser species will provide more BTU's. The table of wood species/densities reveals more helpful guidelines.

STARTING A FIRE

1. To start a fire in your fireplace properly, first check the operation of the flue damper.

To open the damper on the LS43ST fireplace, pull the center damper handle straight down. To close push handle up. The damper is NOT ADJUSTABLE between the open and closed position.

2. The grate in the firebox should be centered on or over the bottom hearth so your fire can breath properly. Crumble and twist plenty of newspapers UNDER the grate and criss-cross some small dry kindling sticks on top of the paper or on the bottom of the grate.

3. Build a pyramid of three split logs (split will start much faster). Arrange the uneven wood to provide plenty of air space between.

4. Now, light the paper at both sides of the firebox.

5. Close the screens to prevent the escape of sparks and embers.

6. Maintain the fire at a reasonable and safe level. Add fuel only at a rate to maintain a steady burn. Avoid large fluctuations - DO NOT OVERFIRE.

7. Close the damper only when your fire is completely out and ashes are cold. Keep closed when fireplace is not in use to prevent unnecessary loss of heated or cooled air.

GLASS DOORS

These fireplaces come with specially designed glass door enclosures in two different styles; Twin Pane and bi-fold design with tempered glass panes. Removal or modifications to the standard glass doors may void your warranty and cause a smoking condition.

WARNING: THESE FIREPLACES SHOULD BE OPERATED ONLY WITH THE DOORS FULLY OPEN OR FULLY CLOSED (SEE FIGURES 2 AND 3). IF DOORS ARE LEFT PARTLY OPEN, GAS AND FLAME MAY BE DRAWN OUT OF THE FIREPLACE OPENING, CREATING RISKS OF BOTH FIRE AND SMOKE.

Care and Cleaning of Your Glass Doors

Never clean the glass when the doors are hot. Do not use ammonia or ammonia based glass or household cleaner to clean the glass or the door frame. An ammonia based cleaner will damage the finish of your glass door.

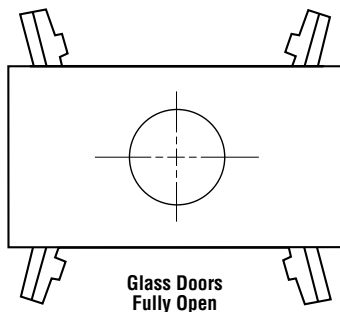

Figure 2

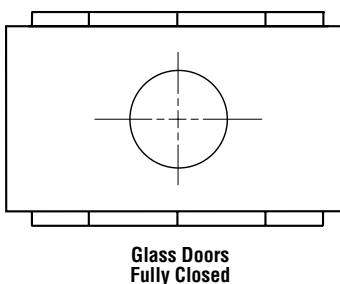

Figure 3

NOTE: DIAGRAMS & ILLUSTRATIONS NOT TO SCALE

In most cases, a clean dampened towel followed by a dry towel will clean the glass. To remove any stubborn stains from the glass, use a mild soap solution and a towel dampened with clean water and then dry with a clean dry towel.

Glass Door Operating Safety Precautions and Instructions

- The fire must always be confined within the boundaries of the fuel grate.
- The fireplace screens must always be closed whenever the fireplace is operated.
- Never slam the glass door since it could cause the glass to break.
- Do not build excessively large or hot fires. Scorching or discoloring of the solid brass or plated brass trim could result.
- Extreme temperature changes can cause glass breakage — do not build a hot fire and close the glass doors if the doors are cold.
- If the tempered glass pane becomes scratched or chipped, it creates a weakness in the glass which can cause the glass to break when heated. Replace the pane of glass by contacting your nearest dealer or distributor.

CAUTION: GLASS AND METAL FRAMES GET HOT — ALWAYS USE HANDLES TO OPEN AND CLOSE THE DOORS.

WARNING: CERTAIN MODEL FIREPLACES REQUIRE THAT THE GLASS DOORS BE CLOSED DURING OPERATION. BE AWARE THAT SAFETY GLASS IS UNPREDICTABLE WHEN HOT AND MAY BREAK, EXPELLING HOT GLASS INTO THE ROOM. ADVISE ALL FAMILY MEMBERS TO REMAIN WELL AWAY FROM THE FIREPLACE WHEN OPERATING WITH DOORS CLOSED TO AVOID ANY POSSIBLE PERSONAL INJURY.

IMPORTANT: Plated polished brass glass doors may have a plastic covering over all brass pieces for protection during shipping and handling. The plastic covering should be removed after installation of the fireplace before its use. Under the plastic covering is a protective lacquer coating which should not be removed. In some instances, if it is removed, irreversible damage to the brass finish could occur. Refer to the following for specific information on plated polished brass. Please understand that the heat of the fire will cause the protective lacquer finish to slightly change to a light caramel color. Do not be alarmed as this is a normal occurrence.

IMPORTANT: The lacquer coating on the polished brass glass doors and trim pieces can be damaged or removed causing corrosion and/or tarnish. To help protect the solid brass; use a non-acidic wax and avoid the over-spray of acidic/alkali based glass cleaners on the brass pieces. If the solid brass begins to turn black, all the protective coating should be removed and the metal re-polished, either by hand or professionally. Subsequently, the finish will not be as "bright" or lustrous without the protective coating. Solid polished brass will acquire a patina over years of use. This is a normal occurrence and can be polished.

COMBUSTION AIR

A proper amount of combustion air is important for your fireplace. Fireplaces consume large amounts of oxygen. It is important to allow an adequate supply of air. If the fireplace is not equipped with an outside air kit, it may not obtain sufficient amounts of combustion air from inside the house or structure in which it is installed. Therefore, the fire may draw from an outside air source and pull air in through the chimney. This may cause smoke spillage into the room.

Smoke spillage often occurs when a fire is first started, until the fireplace and the chimney has had the opportunity to "come up to temperature" and to begin to function normally. If smoke spillage problems persist, a window may be opened just a crack to allow the proper flow of combustion air to the fireplace.

If your fireplace is equipped with an outside combustion air kit, keep open at all times when fire is burning and close when fire is out to prevent cold air intrusion.

Combustion Air Control

On the LS43ST Series fireplace, the control lever that operates the outside combustion air valve is located on the lower side behind the screen panel. Push the lever all the way up to open the air valve and pull the lever all the way down to close the air valve (*Figure 4*).

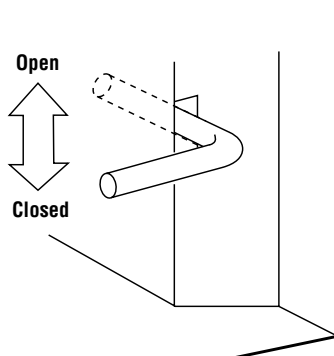

Figure 4

The outside air damper should be kept closed on all fireplaces except when the fireplace is in operation. If there is no heat present in the firebox, the air damper should be closed at night before retiring to prevent intrusion of outside air into the home.

LINTEL EXTENSION

The LS43ST See-Through Factory-Built Fireplace was designed, tested and listed with an 20" (508 mm) high viewing area, floor to lintel. However, varying conditions such as altitude, climate, wood type, moisture content of fuel, dwelling design peculiarities, average ambient air pressure and humidity may effect the performance of this fireplace. If an unacceptable amount of smoking occurs while the doors are open, the adjustable lintel can be moved to correct the smoking condition.

The lintel extension can be lowered a maximum of 2" (51 mm) using a predrilled hole located at the top of the lintel extension.

To lower the lintel extension on the LS43ST, remove the two screws from both ends of the lintel extension and at the center (located behind the screen assembly). Slide the lintel extension down and align the desired holes in the lintel extension with the holes in the lintel frame. Reattach using the screws previously removed. Repeat this procedure for the lintel extension on the opposite side of the fireplace. (*Figure 5*)

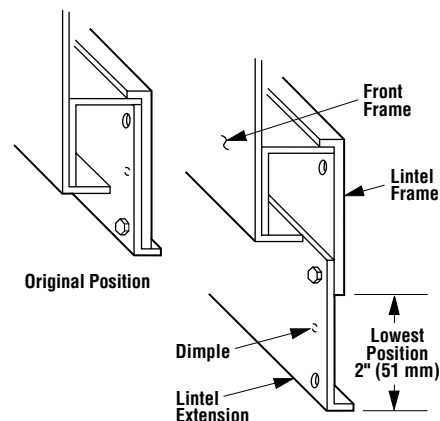

Figure 5

REFRACTORIES

All fireboxes contain a furnace refractory floor. Some models also have refractory sides and backs. These refractories are reinforced with steel, but can be broken by improper use. Dropping logs on the bottom refractory and building fires directly against the refractories can cause premature burnout of these components. It may easily be repaired or replaced at costs far below repair and maintenance for masonry fireplaces.

Proper care and "burn-in" of the firebox will prolong the period of enjoyment without extensive maintenance. For the first few uses, build small fires – not roaring infernos. The materials used in the refractories contain and absorb moisture. It is important to "cure" the refractories by building only modest fires.

Under normal usage, it is expected that hairline cracks will appear in the refractory surface. These hairline cracks do not affect the safe operation of the fireplace.

Refractories should be replaced when:

1. The crack opens more than 1/4" (19 mm).
2. Pitting in the surface is extensive and pits become deeper than 3/16" (4.76 mm).
3. Any piece of refractory larger than 2" (51 mm) in radius and 3/16" deep becomes dislodged.

If your refractory has a crack less than 1/4" (19 mm) in width, a simple Refractory Patch Kit, Model RPK, can easily be used to fill the crack and repair the refractory.

If conditions 1, 2 or 3 occur, the refractory should be replaced. For minor defects, repair as noted above.

MAINTENANCE GUIDELINES

Your fireplace is designed to operate trouble-free with minimum maintenance. However, like any fine appliance, it deserves and requires some housekeeping attention.

Your fireplace will perform better – and certainly look more attractive to family and friends – if it is cleaned before each use. Before the first seasonal use in Autumn and after the last fire in Spring, it is important to inspect the fireplace system carefully. We recommend at least two complete fireplace inspections a year.

Before Each Use

1. Clean the firebox of excessive ashes. Some owners prefer to leave a small layer to insulate the cold refractory below the grate which helps fire starting.

Your fireplace has a factory supplied grate installed, it is permissible to remove the grate for cleaning; however, the grate must be re-attached to the fireplace before the next burn.

2. Keep the fireplace screens clean so combustion air flows freely.
3. Spot check the brick-like refractory for small cracks. Heat from the fire expands it slightly. When it cools, it contracts.

Twice A Year Check-Up

Normally, twice a year, you should inspect your fireplace following this list:

1. Inspect the opening in your chimney top and remove any debris that could clog it. The cap is usually held in place by four (4) screws, which remove easily for checking or cleaning the full length of the flue from above. Remove the chimney top while wearing gloves to guard against any sharp metal edges.
2. Inspect the entire flue from the top down for obstructions such as birds nests, leaves, etc. This may be done by using a flexible handled chimney cleaning brush. If the chimney contains offset/return elbows; a soft brush cleaning from the top down to any elbow and then from the firebox up to the offset/return section is the proper method. The beam from a powerful flashlight will help in this inspection.
3. Look up from inside the fireplace (damper open) to see any obstructions in the lower flue area. If present, shut the damper and glass doors (if installed) to seal the firebox and contain any soot that might fall. If you do not have glass doors installed, a damp sheet covering the fireplace opening and sealed with masking tape will do. Then clean the flue from the top down (if an offset system, clean per Step 2) using a proper size chimney brush with flexible pole sections. Don't open the doors or remove the sheet until all soot has settled. Vacuum, don't sweep.
4. Check the metal flashing and seals around your chimney. Seal any cracks or loose nailhead openings to prevent roof leaks.
5. Clean the firebox thoroughly by using a soft brush or equivalent.

WARNING: CONTINUED OVER FIRING CAN PERMANENTLY DAMAGE YOUR FIREPLACE SYSTEM. SOME EXAMPLES OF OVERFIRING ARE:

- BURNING QUANTITIES OF SCRAP LUMBER, PINE BRANCHES, PAPER OR CARDBOARD BOXES WHICH EXCEED THE VOLUME OF THE NORMAL LOG FIRE.
- BURNING TRASH, CHEMICALS OR CHEMICALLY TREATED COMBUSTIBLES.

Creosote Formation and Removal

When wood is burned slowly, it produces tar and other organic vapors, which combine with expelled moisture to form creosote. The creosote vapors condense in the relatively cool chimney flue of a slow-burning fire. As a result, creosote residue accumulates on the flue lining. Creosote makes an extremely hot fire when ignited.

The chimney should be inspected at least twice yearly during the heating season to determine if a creosote build-up has occurred.

If creosote has accumulated, it should be removed to reduce the risk of a chimney fire.

If creosote build-up is found, do not use chemical chimney cleaners that are poured on a hot fire. The manufacturer considers them dangerous and they generally only work on the flue section nearest the fire, leaving the rest of the flue unaffected. It is best to take the time to clean the flue as previously described or have the chimney professionally cleaned by a qualified chimney sweep.

TROUBLE SHOOTING No Smoking Allowed

Your new fireplace is designed not to smoke if properly installed and operated per our instructions. If you do experience a problem, here are several things to check:

1. Remember – always check to ensure your flue damper is in the open position before lighting a fire!
2. When lighting your fire, a little smoke may escape into the room – more likely if the chimney is cold. To correct this, hold a lighted newspaper up inside the firebox near the open flue damper. This will turn around any downdraft and clear the flue of cold air. As your log fire burns below, the updraft will improve as the chimney heats up.

3. Is your fire too far forward? Move it toward the back with your poker. Keep the fire well within the confines of your fuel grate.

4. Keep your fire up on the grate and the refractory below free of excessive ashes. The fire needs plenty of air movement around the logs.

5. If smoking occurs an hour or two after lighting the fire, perhaps your well-insulated house is too airtight and there is scarcely any way for replacement air to enter and feed the fire. Check to see if your outside combustion air kit (if installed) is open. Check outside to ensure no obstructions are in front of exterior air entry. Open a window slightly, open doors to one or two rooms and see if this stops the smoking.

6. Is a vent fan, exhaust hood or central heating/cooling system stealing combustion air from your fireplace? If their volume is high enough, this can cause negative pressure and an unwanted downdraft – and smoking.

7. Is your wood fuel too wet or unseasoned? Or does it contain some chemical substance that causes sputtering, smoking and toxic fumes?

8. *Figure 5* illustrates the correct height of your chimney top. It is unlikely that your installation does not adhere to the installation instructions. However, if not correct, you could experience an unusual downdraft. Usually, the best solution is to increase the chimney height. This may also be necessary if nearby trees, adjoining roof lines or a hill is causing a downdraft condition.

9. Remember, your fireplace has been designed as a supplemental heating device only, it is not intended to heat your entire home.

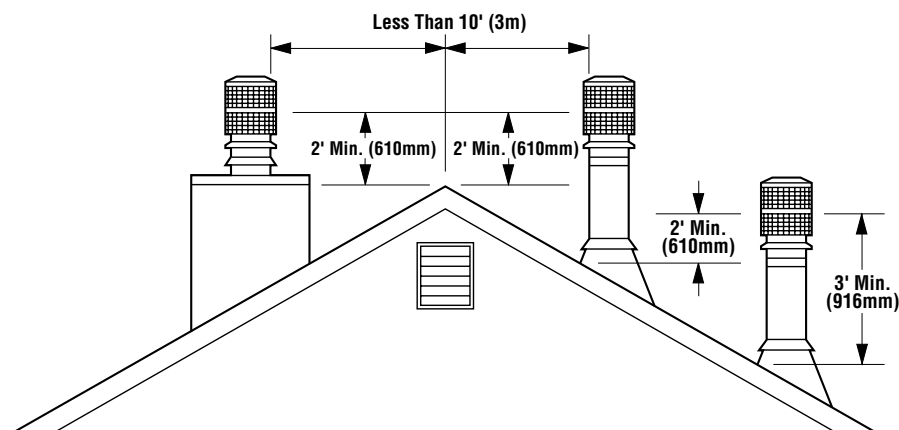
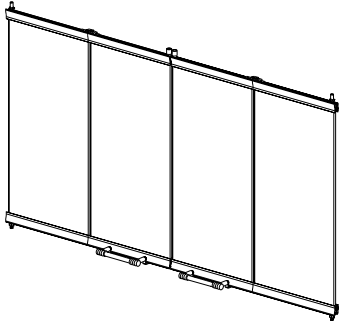

Figure 5

NOTE: DIAGRAMS & ILLUSTRATIONS NOT TO SCALE

ACCESSORIES AND COMPONENTS



Bi-Fold Doors

38/43LBF
38/43LBF-BB
38/43LBF-BS

Bi-Fold Doors

Your fireplace can be fitted with beautiful bi-fold doors. Model LBF doors are available for use with these fireplace. Doors are easily fitted to the fireplace opening. Model LBF doors come with standard black finish. Model LBF-BB doors have a beautiful bright brass finish. Model LBF-BS doors have the striking look of brushed steel.

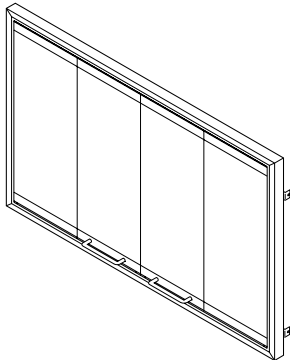

Symphony Doors

43LSBF
43LSBF-B

Symphony Doors

Your fireplace can be fitted with attractive Symphony doors. Symphony series Bi-Fold doors come standard with a decorator satin black finish and may be purchased in a polished brass finish designated by the -B suffix to the model/size number.

To ensure warranty and to prevent a potential fire hazard, do not use any other doors on these appliances.

ENJOY YOUR FIREPLACE

If you encounter any problems or have any questions regarding the installation of operation of your fireplace system, contact your distributor. For your nearest distributor contact:

LENNOX HEARTH PRODUCTS
1110 West Taft Avenue
Orange, CA 92865

REPLACEMENT PARTS LIST

No.	DESCRIPTION	Model LS43ST	
		Part No.	Qty.
1.	See-Through Fireplace Assembly	23M92	1
2.	Refractory, Ashlip	LB-96824	2
3.	Refractory, Hearth	LB-96826	1
4.	Refractory, Side	LB-96825	2
5.	Grate Assembly	LB-96813	1
6.	Refractory Retainer	LB-96819	2
7.	Standoff, Refractory	LB-96839	1
8.	Screen	161110	2
9.	Screen Rod	LB-97092	2
10.	Track, Door Guide	LB-98176	2
11.	Door Support Spring	LB-98109	4
12.	Lintel Extension	LB-96828	2
13.	Chimney Connector, Outer	LB-98307	1
14.	Bracket, Header	LB-96822	4
15.	Standoff	LB-98244	4
16.	Damper Assembly	LB-96832	1
17.	Lattice Crossmember	LB-96840	6
18.	Lattice Member	LB-96841	8
19.	Gas Line Conduit	LB-96833	4
20.	Air Kit	LB-96845	1
21.	Doors (not included)	REF.	-

REPLACEMENT PARTS

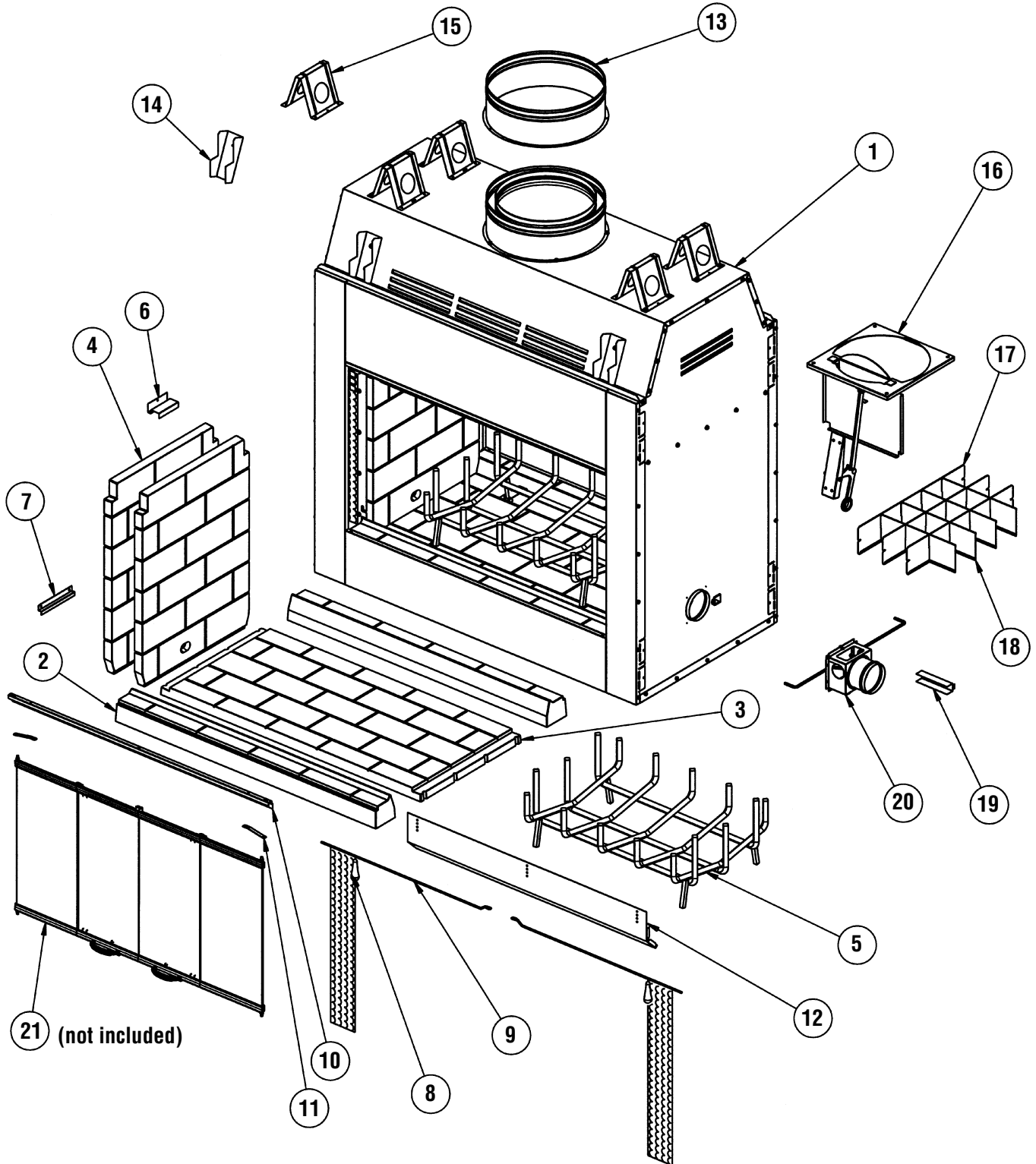

NOTE: DIAGRAMS & ILLUSTRATIONS NOT TO SCALE

The manufacturer reserves the right to make changes at any time, without notice, in design, materials, specifications, prices and also to discontinue colors, styles and products. Consult your local distributor for fire code information.