



HEARTH PRODUCTS

P/N 875024M Rev. E 04/2013

This manual is part of a set of two supporting this product. Refer to P/N 850023M for Installation Instructions.

Ce manuel est disponible en français, simplement en faire la demande. Numéro de la pièce 875024CF.



OTL Report No. 116-F-27-5

# CARE AND OPERATION INSTRUCTIONS

## MPB B-Vent See-Through Gas Fireplaces

## MERIT Plus<sup>®</sup> SERIES

### MODELS

#### MILLIVOLT:

MPB35ST-NM-B  
MPB35ST-PM-B

#### ELECTRONIC:

MPB35ST-NE-B

### WHAT'S INSIDE

Table of Contents	2
Safety and Your Fireplace	2
FREE Safety Guard Offer (Protects Against Burns)	2
Important Safety Information	4
Attaching the Safety-in-Operation Warnings	5
[EN FRANÇAIS] L'information de sûreté importante	3-4
Apposition des mises en garde relatives à la sécurité d'utilisation	5
[EN ESPAÑOL] Información importante de seguridad	3-4
Colocación de advertencias de seguridad en operación	5

**Decorative Product: Not for use as a heating appliance.**

**NOTICE: Fireplace is not to be operated by a thermostat.**



**INSTALLER:** Leave this manual with the appliance.

**CONSUMER:** Retain this manual for future reference.

**INSTALLATEUR :** Laissez cette notice avec l'appareil.

**CONSOMMATEUR :** Conservez cette notice pour consultation ultérieure.



# ! WARNING / AVERTISSEMENT / AVISO

**HOT GLASS WILL CAUSE BURNS.  
DO NOT TOUCH GLASS UNTIL COOLED  
NEVER ALLOW CHILDREN TO TOUCH GLASS.**



**UNE SURFACE VITRÉE CHAUDE PEUT CAUSER DES BRÛLURES.  
LAISSER REFROIDIR LA SURFACE VITRÉE AVANT D'Y TOUCHER.  
NE PERMETTEZ JAMAIS À UN ENFANT DE TOUCHER LA SURFACE VITRÉE.**

**EL VIDRIO CALIENTE CAUSARÁ QUEMADURAS.  
USTED DEBE NUNCA TOCAR EL VIDRIO CALIENTE.  
LOS NIÑOS DEBEN NUNCA TOCAR EL VIDRIO.**

**WARNING:** If the information in these instructions is not followed exactly, a fire or explosion may result, causing property damage, personal injury, or death.

- Do not store or use gasoline or other flammable vapors and liquids in the vicinity of this or any other appliance.
- **WHAT TO DO IF YOU SMELL GAS:**
  - Do not try to light any appliance.
  - Do not touch any electrical switch; do not use any phone in your building.
  - Immediately call your gas supplier from a neighbor's phone. Follow the gas supplier's instructions.
  - If you cannot reach your gas supplier, call the fire department.
- Installation and service must be performed by a qualified installer, service agency or the gas supplier.

**AVERTISSEMENT :** Assurez-vous de bien suivre les instructions données dans cette notice pour réduire au minimum le risque d'incendie ou d'explosion ou pour éviter tout dommage matériel, toute blessure ou la mort.

- Ne pas entreposer ni utiliser d'essence ni d'autres vapeurs ou liquides inflammables dans le voisinage de cet appareil ou de tout autre appareil.
- **QUE FAIRE SI VOUS SENTEZ UNE ODEUR DE GAZ :**
  - Ne pas tenter d'allumer d'appareil.
  - Ne touchez à aucun interrupteur. Ne pas vous servir des téléphones se trouvant dans le bâtiment où vous trouvez.
  - Appelez immédiatement votre fournisseur de gaz depuis un voisin. Suivez les instructions du fournisseur.
  - Si vous ne pouvez rejoindre le fournisseur de gaz, appelez le service des incendies.
- L'installation et l'entretien doivent être assurés par un installateur ou un service d'entretien qualifié ou par le fournisseur de gaz.

Thank you for your purchase. We appreciate your business!

Please carefully read and follow all instructions in this manual.  
**Pay special attention to all warnings and safety information.**

Following these safety, care, and operation instructions will help ensure many years of dependable and enjoyable service from your fireplace.

### Register your product online today!

To help us keep you up-to-date on product information and offers, please take a few moments to register your product online at

[www.LennoxHearthProducts.com](http://www.LennoxHearthProducts.com)  
> Owner Resources > Product Registration

## • FREE SAFETY GUARD OFFER •

*The Lennox® SAFETY GUARD protects against severe burns and injuries by preventing direct contact with the front glass surface of your fireplace.*

To receive your FREE SAFETY GUARD, call 1-800-655-2008, or visit [www.LennoxHearthProducts.com/buying-guide/safety-guard](http://www.LennoxHearthProducts.com/buying-guide/safety-guard)

**NOTE: Safety Guards may not be available for some older models that are no longer in production.**

## Table of Contents

<b>Safety and Your Fireplace</b> .....	<b>2</b>
<b>Important Safety Information</b> .....	<b>4</b>
<b>Attaching the Safety-in-Operation Warnings</b> .....	<b>5</b>
General Information .....	6
Operation/Care of Your Appliance .....	8
Gas Controls/Control Compartment, Access .....	8
Variable Flame Adjustment .....	9
Venting Operation / Spill Switch .....	9
Outside Combustion Air Control .....	10
Maintenance .....	11
Front Glass Enclosure Panel, Removal and Installation .....	12
Logs, Vermiculite & Ember Placement .....	12
Burner Adjustments .....	15
Millivolt Appliance Checkout .....	16
Electronic Appliance Checkout .....	16
Warranty .....	17
Replacement Parts .....	17
Product Reference Information .....	17
Wiring Diagrams .....	17
Accessory Components .....	18
Lighting Instructions – Millivolt .....	22
Lighting Instructions – Electronic .....	24
Maintenance Schedule .....	26
Troubleshooting Guide – Millivolt .....	27
Troubleshooting Guide – Electronic .....	27
Replacement Parts List .....	29



We recommend that our gas hearth products be installed and serviced by professionals who are certified in the U.S. by the National Fireplace Institute® (NFI) as NFI Gas Specialists.

# Safety and Your Fireplace

## All parts of your Lennox Hearth Products fireplace get EXTREMELY HOT!

- To prevent severe burns and injuries, install a screen or physical barrier to prevent direct contact with the glass.

**To order a FREE Lennox® SAFETY GUARD for your fireplace, see details at left.**

- Follow the safety instructions below and be sure everyone in your household understands this burn hazard:

- **The surfaces on your fireplace get EXTREMELY HOT!**

- **The glass on the front of the fireplace reaches EXTREMELY HIGH temperatures and can cause severe burns if touched.**



- **Keep children away from an operating fireplace. Closely supervise children in any room where a fireplace is operating to prevent contact with glass.**

- **Keep clothing, furniture, gasoline, and other flammable liquids away from the fireplace.**

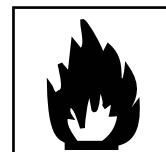

- **Even after the gas is turned off, fireplace surfaces remain extremely hot.**

- Be sure to attach the enclosed **Safety-in-Operation Warnings** where you turn on your fireplace, to help remind everyone of the dangers associated with high temperatures (see page 5).

- Read **Important Safety Information** on page 4.

[FRENCH]

## ***La sécurité et votre foyer***

**Toutes les parties de votre foyer  
Lennox Hearth Products deviennent  
EXTRÊMEMENT CHAUDES !**

- Afin d'éviter de vous brûler gravement ou de vous blesser, installez une grille ou une barrière physique pour empêcher tout contact direct avec la vitre.

***Pour commander un PANNEAU DE PROTECTION  
Lennox® GRATUIT pour votre foyer, consultez  
les détails dans la partie gauche.***

- Suivez les instructions de sécurité ci-dessous et veillez à ce que tous les membres de votre famille soient conscients du danger de brûlure encouru :
  - **Les surfaces de votre foyer deviennent EXTRÊMEMENT CHAUDES !**
  - **La vitre située à l'avant du foyer atteint des températures EXTRÊMEMENT ÉLEVÉES et peut causer de graves blessures en cas de contact.**
  - **Tenez les enfants à l'écart du foyer lorsqu'il fonctionne. Surveillez attentivement les enfants dans les pièces où un foyer est utilisé afin d'éviter qu'ils ne soient en contact avec la vitre.**
  - **Tenez tous les vêtements, les meubles, l'essence et tout autre liquide inflammable à l'écart du foyer.**
  - **Même après fermeture du gaz, les surfaces du foyer restent extrêmement chaudes.**
- Veillez à coller les **Étiquettes de mise en garde relatives à la sécurité d'utilisation** à l'endroit où vous utilisez le foyer, pour rappeler à tous les utilisateurs les dangers liés aux températures élevées (**voir page 5**).
- Lisez la section **Informations importantes relatives à la sécurité**, page 4.

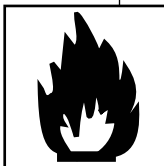

[SPANISH]

## ***Seguridad y su chimenea***

**¡Todas las partes de la chimenea  
Lennox Hearth Products se ponen  
MUY CALIENTES!**

- Instale una malla o barrera física para evitar el contacto directo con el vidrio y prevenir las quemaduras y lesiones graves.

***Ver los detalles a la izquierda para ordenar  
un Lennox® SAFETY GUARD GRATIS  
para su chimenea.***

- Siga las instrucciones de seguridad a continuación y asegúrese de que todos en su hogar sepan acerca de este peligro de quemadura:
  - **¡Las superficies de la chimenea se ponen MUY CALIENTES!**
  - **El vidrio delante de la chimenea alcanza temperaturas EXTREMADAMENTE ALTAS y puede causar quemaduras graves si se toca.**
  - **Mantenga a los niños alejados de la chimenea en funcionamiento. Supervise en forma cercana a los niños en cualquier cuarto donde haya una chimenea funcionando para impedir el contacto con el vidrio.**
  - **Mantenga la ropa, mobiliario, gasolina y otros líquidos inflamables alejados de la chimenea.**
  - **Aún después de haber apagado el gas, las superficies de la chimenea permanecen extremadamente calientes.**
- Asegúrese de colocar las **Etiquetas de advertencia de seguridad de operación** en el lugar donde enciende la chimenea, para que todos recuerden los peligros asociados con las altas temperaturas (**ver la página 5**).
- Lea la **Información importante** de seguridad en la **página 4**.

## Important Safety Information

1. **WARNING:** Do not operate appliance with the glass front removed, cracked or broken.
2. Do not use this appliance if any part has been under water. Immediately call a qualified service technician to inspect the appliance and to replace any part of the control system and any gas control which has been under water.
3. Due to high temperatures, the appliance should be located out of traffic and away from furniture and draperies.
4. Children and adults should be alerted to the hazards of high surface temperature and should stay away to avoid burns or clothing ignition.
5. Clothing or other flammable material should not be placed on or near the appliance.
6. Young children should be carefully supervised when they are in the same room as the appliance. Toddlers, young children, and others may be susceptible to accidental contact burns. A physical barrier is recommended if there are at-risk individuals in the house. To restrict access to a fireplace or stove, install an adjustable safety gate to keep toddlers, young children, and other at-risk individuals out of the room and away from hot surfaces.
7. Any safety screen or guard removed for servicing an appliance must be replaced prior to operating the appliance.
8. Installation and repair should be done by a qualified service person. The appliance should be inspected before use and at least annually by a professional service person. More frequent cleaning may be required due to excessive lint from carpeting, bedding material, et cetera. It is imperative that control compartments, burners, and circulating air passageways of the appliance be kept clean. See maintenance instructions on page 11.

## L'information de sûreté importante

1. **AVERTISSEMENT.** Ne pas utiliser l'appareil si le panneau frontal en verre n'est pas en place, est craqué ou brisé.
2. Ne pas utiliser cet appareil s'il a été plongé, même partiellement, dans l'eau. Appeler un technicien qualifié pour inspecter l'appareil et remplacer toute partie du système de commande et toute commande qui a été plongée dans l'eau.
3. En raison des températures élevées, l'appareil devrait être installé dans un endroit où il y a peu de circulation et loin du mobilier et des tentures.
4. Les enfants et les adultes devraient être informés des dangers que posent les températures de surface élevées et se tenir à distance afin d'éviter des brûlures ou que leurs vêtements ne s'enflamment.
5. On ne devrait pas placer de vêtements ni d'autres matières inflammables sur l'appareil ni à proximité.
6. Les jeunes enfants devraient être surveillés étroitement lorsqu'ils se trouvent dans la même pièce que l'appareil. Les tout petits, les jeunes enfants ou les adultes peuvent subir des brûlures s'ils viennent en contact avec la surface chaude. Il est recommandé d'installer une barrière physique si des personnes à risques habitent la maison. Pour empêcher l'accès à un foyer ou à un poêle, installez une barrière de sécurité ; cette mesure empêchera les tout petits, les jeunes enfants et toute autre personne à risque d'avoir accès à la pièce et aux surfaces chaudes.
7. Tout écran ou protecteur retiré pour permettre l'entretien de l'appareil doit être remis en place avant de mettre l'appareil en marche.
8. L'installation et la réparation devrait être confiées à un technicien qualifié. L'appareil devrait faire l'objet d'une inspection par un technicien professionnel avant d'être utilisé et au moins une fois l'an par la suite. Des nettoyages plus fréquents peuvent être nécessaires si les tapis, la literie, et cetera produisent une quantité importante de poussière. Il est essentiel que les compartiments abritant les commandes, les brûleurs et les conduits de circulation d'air de l'appareil soient tenus propres. Voyez les instructions d'entretien à la page 11.

[SPANISH]

## Información importante de seguridad

1. **ADVERTENCIA:** No opere el artefacto con el frente de vidrio quitado, agrietado o roto.
2. No use este artefacto si alguna de sus partes ha estado bajo agua. Llame de inmediato a un técnico de servicio calificado para que inspeccione el artefacto y reemplace cualquier parte del sistema de control y cualquier control de gas que haya estado bajo agua.
3. Debido a las altas temperaturas, el artefacto debe situarse fuera de las áreas de tráfico y lejos del mobiliario y cortinas.
4. Se debe alertar a los niños y adultos sobre los peligros de las altas temperaturas en la superficie y que se mantengan alejados para evitar quemaduras o ignición de la ropa.
5. No debe colocarse ropa u otros materiales inflamables sobre y cerca del artefacto.

6. Se debe supervisar de cerca a los niños cuando estén en el mismo cuarto que el artefacto. Los niños pequeños, los jóvenes y otras personas pueden ser susceptibles a quemaduras por contacto accidental. Se recomienda instalar una barrera física si hay personas en riesgo en la casa. Para restringir el acceso a una chimenea o estufa, instale una puerta de seguridad ajustable para mantener a los niños pequeños, jóvenes y otras personas en riesgo fuera del cuarto y lejos de las superficies calientes.
7. Cualquier malla o resguardo de seguridad quitado para dar servicio a un artefacto, debe reinstalarse antes de operar el artefacto.
8. Una persona de servicio competente debe realizar la instalación y reparación. Una persona de servicio profesional debe inspeccionar el artefacto antes de usar al menos una vez por año. Se puede requerir limpieza más frecuente debido a la pelusa excesiva del alfombrado, del material de cobijas, etc. Es imprescindible mantener limpios los compartimientos de control, los quemadores y los pasajes de circulación del aire del artefacto. Ver las instrucciones de mantenimiento en la página 11.

## HOMEOWNER'S INSTRUCTIONS - ATTACHING SAFETY IN OPERATION WARNINGS

### ATTACHING SAFETY IN OPERATION WARNINGS

Your fireplace has been furnished with safety instruction labels that are to be affixed to the operation and control point of the fireplace. A safety instruction label should be affixed to the wall switch plate where the fireplace is turned on and off (*See Figure A*) and if used on the remote control handheld transmitter (*Figure B*). The warnings should already have been put in place when the fireplace initial set-up was completed. If they are not affixed at these spots, locate the multi-lingual adhesive labels provided with these instructions and proceed as follows:

1. Locate the wall switch that controls the fireplace (verify the switch operates the fireplace by turning it on and off). Clean the wall switch plate thoroughly to remove any dust and oils. Affix the label to the surface of the plate of the wall switch that controls the fireplace (*Figure A*). Choose the language primarily spoken in the home.
2. If a remote control is used to control the fireplace, locate the transmitter and clean it thoroughly to remove any dust and oils. Affix the label to the surface of handheld transmitter (*Figure B*). Choose the language primarily spoken in the home.
3. If you are unable to locate the labels, please call Lennox Hearth Products or your nearest Lennox Hearth Products dealer to receive additional safety instruction labels free of charge.

Cat. No. H8024 Replacement Label Kit

**LENNOX HEARTH PRODUCTS**  
1-800-655-2008

*NOTE: English is red text on clear label. French and Spanish are white text on black label.*

### SAFETY LABEL DIAGRAMS



### APPOSITION DES MISES EN GARDE RELATIVES À LA SÉCURITÉ D'UTILISATION

Votre foyer a été livré avec des étiquettes de sécurité qui doivent être collées à côté des dispositifs de contrôle du foyer. Une étiquette de sécurité devrait être collée sur la plaque de l'interrupteur contrôlant l'allumage du foyer (*voir Figure A*) et, le cas échéant, sur le boîtier de la télécommande (*Figure B*). Les mises en garde auraient dû être collées au moment de l'installation initiale du foyer. Si ce n'est pas le cas, prenez les étiquettes adhésives multilingues fournies avec ces instructions et procédez comme suit:

1. Repérez l'interrupteur qui contrôle le foyer (vérifiez que l'interrupteur contrôle le fonctionnement du foyer en le faisant basculer de Marche à Arrêt, et vice-versa). Nettoyez soigneusement la plaque murale de l'interrupteur pour éliminer la poussière et les traces de graisse ou d'huile. Collez l'étiquette sur la surface de la plaque de l'interrupteur mural qui contrôle le foyer (*Figure A*). Choisissez la langue qui est principalement parlée dans la résidence du propriétaire.
2. Si une télécommande est utilisée pour contrôler le foyer, nettoyez la soigneusement pour éliminer la poussière et les traces de graisse ou d'huile. Collez l'étiquette sur le boîtier de la télécommande (*Figure B*). Choisissez la langue qui est principalement parlée dans la résidence du propriétaire.
3. Si vous ne trouvez pas les étiquettes, veuillez appeler Lennox Hearth Products ou votre distributeur Lennox Hearth Products local pour recevoir gratuitement des étiquettes supplémentaires.

Étiquettes de remplacement, n° cat. H8024

**LENNOX HEARTH PRODUCTS**  
1-800-655-2008

*Remarque : Le texte anglais est rouge sur un support transparent. Le texte français et espagnol est blanc sur un support noir.*

### DIAGRAMMES DES ÉTIQUETTES DE SÉCURITÉ



### COLOCACIÓN DE ADVERTENCIAS DE SEGURIDAD EN OPERACIÓN

Su chimenea incluye etiquetas de instrucciones de seguridad que deben colocarse en el punto de operación y control de la chimenea. Se debe colocar una etiqueta de instrucciones de seguridad en la placa del interruptor de pared desde el cual se enciende y se apaga la chimenea (*ver la Figura A*) y en el transmisor de control remoto (*Figura B*) si se usa. Las advertencias ya deben haberse colocado cuando se completó la instalación inicial de la chimenea. Si no están colocadas en estos lugares, encuentre las etiquetas adhesivas multilingües proporcionadas con estas instrucciones y prosiga de la siguiente manera:

1. Identifique el interruptor de pared que controla la chimenea (verifique que el interruptor opera la chimenea encendiéndola y apagándola). Limpie bien la placa del interruptor de pared para quitar el polvo y aceite. Pegue la etiqueta en la superficie de la placa del interruptor que controla la chimenea (*Figura A*). Seleccione el idioma que más se habla en la casa.
2. Si se usa un control remoto para controlar la chimenea, encuentre el transmisor y límpielo bien para quitar el polvo y aceite. Pegue la etiqueta en la superficie del transmisor (*Figura B*). Seleccione el idioma que más se habla en la casa.
3. Si no puede encontrar las etiquetas, sírvase llamar a Lennox Hearth Products o al distribuidor de Lennox Hearth Products más cercano para recibir etiquetas de instrucciones de seguridad adicionales gratuitas.

Juego de etiquetas de repuesto - N° de cat. H8024

**LENNOX HEARTH PRODUCTS**  
1-800-655-2008

*Nota: La etiqueta en inglés es transparente con texto rojo. Las etiquetas en francés y español son negras con texto blanco.*

### DIAGRAMAS DE ETIQUETAS DE SEGURIDAD



*Illustrations are for example only. Your accessories may be different.*

*Les illustrations sont par exemple uniquement. Vos accessoires peuvent être différents.*

*Las ilustraciones son sólo ejemplos. Tu accesorios pueden ser diferentes.*

**Figure A**



**Figure B**



## APPLIANCE INSTALLATION, SERVICE, AND MAINTENANCE NOTICES

**WARNING:** Improper installation, adjustment, alteration, service or maintenance can cause injury or property damage. Refer to the owner's information manual provided with this appliance. For assistance or additional information consult a qualified installer, service agency or the gas supplier.

**AVERTISSEMENT :** Une installation, un réglage, une modification, une réparation ou un entretien mal effectué peut causer des dommages matériels ou des blessures. Voir la notice de l'utilisateur qui accompagne l'appareil. Pour de l'aide ou des renseignements supplémentaires, consultez un installateur, un technicien agréé ou le fournisseur de gaz.

Only trim kit(s) supplied by the manufacturer shall be used in the installation of this appliance.

Seules les trousse de garniture fournies par le fabricant doivent être utilisées pour l'installation de cet appareil.

These appliances must not be connected to a chimney or flue serving a separate solid fuel burning appliance.

Draft relief openings must not be covered or blocked.

Any change to this appliance and/or its operating controls is dangerous. Improper installation or use of this appliance can cause serious injury or death from fire, burns, explosion or carbon monoxide poisoning.

**CARBON MONOXIDE POISONING:** Early signs of carbon monoxide poisoning are similar to the flu with headaches, dizziness and/or nausea. If you have these signs, obtain fresh air immediately. Turn off the gas supply to the appliance and have it serviced by a qualified professional, as it may not be operating correctly. Some people are more affected by carbon monoxide than others, including pregnant women, people with heart or lung disease or anemia, those under the influence of alcohol, and those at high altitudes.

Turn off gas and electrical power to the fireplace and allow it to cool before cleaning or servicing the appliance.

## APPLIANCE OPERATION NOTICES

Do not operate appliance with the glass front removed, cracked, or broken.

These fireplaces are vented gas appliances. Do not burn wood or other material in these appliances.

This appliance is only for use with the type of gas indicated on rating plate. This appliance is not convertible for use with other gases, unless a certified kit is used.

These appliances are designed to operate on natural gas or propane gas only. The use of other fuels or combinations of fuels will degrade the performance of this system and may be dangerous.

Cet appareil doit être utilisé uniquement avec les types de gaz indiqués sur la plaque signalétique. Ne pas l'utiliser avec d'autres gaz sauf si un kit de conversion certifié est installé.

Provide adequate clearances around air openings and adequate accessibility clearance for service and proper operation. Never obstruct the front or back openings of the appliance.

Do not use this appliance if any part has been under water. Immediately call a qualified service technician to inspect the appliance and to replace any part of the control system and any gas control that has been under water.

These fireplaces are designed as decorative appliances and are not intended for use as area heaters. They must not be equipped with wall thermostats or remote controls with thermostat functions.

**CAUTION:** Hot while in operation. Do not touch. Severe Burns may result. Keep children, clothing furniture, gasoline and other liquids having flammable vapors away.

**ATTENTION :** L'appareil est chaud lorsqu'il fonctionne. Ne pas toucher l'appareil. Risque de brûlures graves. Surveiller les enfants. Garder les vêtements, les meubles, l'essence ou autres liquides produisant des vapeur inflammables loin de l'appareil.

This appliance uses room air for combustion. It is imperative that provisions for adequate combustion and ventilation air be made. This appliance is NOT designed to and will not operate in a negative pressure. Contact your dealer if you suspect such a situation exists.

## WARRANTY INFORMATION

Your gas appliance is covered by a limited 20-year warranty. You will find a copy of the warranty accompanying this manual. Please read the warranty to be familiar with its coverage.

Retain this manual. File it with your other documents for future reference.

Failure to comply with the installation and operating instructions provided will result in an improperly installed and operating appliance, voiding its warranty.

Do not attempt to alter or modify the construction of the appliance or its components. Any modification or alteration may void the warranty, certification, and listings of this unit.

## NEGATIVE PRESSURE WARNING

### **WARNING**

**B-Vent appliances are not designed to operate in negatively pressured environments (pressure within the home is less than pressures outside). Significant negatively pressured environments caused by weather, home design, or other devices may impact the operation of these appliances. Negative pressures may result in poor flame appearance, sooting, damage to property and/or severe personal injury. Do not operate these appliances in negatively pressured environments.**

## General Information

The fireplace models covered in this manual are B-vented decorative gas appliances designed for residential application.

The *Millivolt* appliances have a millivolt gas control valve with piezo ignition system.

The *Electronic* appliances have an electronic intermittent pilot ignition system. External electrical power is required to operate these units.

These appliances comply with National Safety Standards and are tested and listed by OMNI-Test Laboratories (Report No. 116-F-27-5) to ANSI Z21.500 (in Canada, CSA 2.22), and CAN/CGA-2.17-M91 in both USA and Canada, as vented gas fireplaces.



The Installation must conform to local codes or, in the absence of local codes, with the National Fuel Gas Code, ANSI Z223.1/NFPA 54-latest edition, or the Natural Gas and Propane Installation Code, CAN/CGA-B149.1-latest edition. The appliance, when installed, must be electrically grounded in accordance with local codes or, in the absence of local codes, the latest edition of the National Electrical Code, ANSI/NFPA 70, or the Canadian Electrical Code, CSA C22.1 - latest editions.

### Millivolt Models - BTU Input

Millivolt models come standard with the manually-modulated gas valve; flame appearance and heat output can be controlled at the gas valve. Input of for these models is shown in **Table 1**.

Input (BTU) Manually-Modulated Gas Valves (millivolt models)		
Models	Fuel Type	Input Rate (BTU / HR)
MPB35ST-NM-B	Nat. Gas	30,000 high 23,000 low
MPB35ST-PM-B	Propane	28,000 high 22,000 low

**Table 1**

### Electronic Models -

Electronic models have a fixed rate gas valve. Input of electronic models is shown in **Table 2**.

Input (BTU) - Fixed Rate (electronic models)		
Models	Fuel Type	Input Rate (BTU / HR)
MPB35ST-NE-B	Nat. Gas	30,000
MPB35ST-PE-B <i>(if field converted)</i>	Pro. Gas	28,000

**Table 2**

### Gas Pressure -

**Tables 3 and 4** show the appliances' gas pressure requirements.

Inlet Gas Supply Pressure (all models)		
Fuel #	Minimum	Maximum
Natural Gas	5.0" WC (1.24 kPa)	10.5" WC (2.62 kPa)
Propane	11.0" WC (2.74 kPa)	13.0" WC (3.24 kPa)

**Table 3**

Manifold Gas Supply Pressure (all models)		
Fuel #	Low (millivolt only)	High
Natural Gas	(Lo) 2.2" WC (.55 kPa)	(Hi) 3.5" WC (.87 kPa)
Propane	(Lo) 6.3" WC (1.57 kPa)	(Hi) 10.0" WC (2.49 kPa)

**Table 4**

Test gauge connections are provided on the front of the millivolt gas control valve, identified IN for the inlet and OUT for the manifold side (see **Figure 2** on **Page 9**). A 1/8" NPT Test gauge connection is provided at the inlet and outlet side of the electronic gas control valve (see **Figure 3** on **Page 9**).

The appliance and its appliance main gas valve must be disconnected from the gas supply piping system during any pressure testing of that system at test pressures **in excess of** 1/2 psi (3.5 kPa).

The appliance must be isolated from the gas supply piping system by closing its equipment shutoff valve during any pressure testing of the gas supply piping system at test pressures **equal to or less than** 1/2 psi (3.5 kPa).

### Orifice Sizes - Sea Level to High Altitude (All Models)

These appliances are tested and approved for installation at elevations of 0-4500 feet (0-1372 meters) above sea level using the standard burner orifice sizes (marked with an "\*" in **Table 5**). For elevations above 4500 feet, contact your gas supplier or qualified service technician.

**Deration** - At higher elevations, the amount of BTU fuel value delivered must be reduced by either:

- Using gas that has been derated by the gas company.
- Changing the burner orifice to a smaller size as regulated by the local authorities having jurisdiction and by the (USA) National Fuel Gas Code NFPA 54/ANSI Z223.1 - latest edition or, in Canada, the CAN/CGA-B149.1 codes - latest edition.

Install the appliance according to the regulations of the local authorities having jurisdiction and, in the USA, the National Fuel Gas Code NFPA 54 / ANSI Z223.1 - latest edition or, in Canada, the CAN/CGA-B149.1 - latest edition.

Flame breadth, height and width will diminish 4% for every 1,000 feet of altitude.

Burner Orifice Sizes (all models)		
Elevation Feet (meters)	Natural Gas drill size (inches)	Propane Gas drill size (inches)
0-4500 (0-1372)	#37 (.104") * 24M10 •	1.55 mm (.061")* 42M79 •

**Table 5** \* Standard size installed at factory  
• Part/Cat. Number

In Canada - CAN/CGA-2.17-M91 (R2009)(high altitude): THE CONVERSION SHALL BE CARRIED OUT BY A MANUFACTURER'S AUTHORIZED REPRESENTATIVE, IN ACCORDANCE WITH THE REQUIREMENTS OF THE MANUFACTURER, PROVINCIAL OR TERRITORIAL AUTHORITIES HAVING JURISDICTION AND IN ACCORDANCE WITH THE REQUIREMENTS OF THE CAN/CGA-B149.1 OR CAN/CGA-B149.2 INSTALLATION CODES.

### Burn-in Period

During the first few fires of this appliance there will be some odor due to the curing of the paint and burning off of lubricants used in the manufacturing process. Depending on your use, the burn-in period may take a few hours or a few days.

**KEEP YOUR HOUSE WELL VENTILATED DURING THE CURING PROCESS. THE ODOR AND HAZE EMITTED DURING THE CURING PROCESS CAN BE QUITE NOTICEABLE AND MAY SET OFF A SMOKE DETECTOR.**

A white film may develop on the glass front during the first few fires as part of the curing process. The glass should be kept clean during the first two weeks of use to prevent the film from baking on (making it very difficult to remove). See **Cleaning Glass** on **Page 11**.

## OPERATION AND CARE OF YOUR APPLIANCE

### WARNING

Young children should be carefully supervised when they are in the same room as the appliance. Toddlers, young children and others may be susceptible to accidental contact burns. A physical barrier is recommended if there are at risk individuals in the house. To restrict access to a fireplace or stove, install an adjustable safety gate to keep toddlers, young children and other at risk individuals out of the room and away from hot surfaces.

### AVERTISSEMENT

Les jeunes enfants devraient être surveillés étroitement lorsqu'ils se trouvent dans la même pièce que l'appareil. Les tout petits, les jeunes enfants ou les adultes peuvent subir des brûlures s'ils viennent en contact avec la surface chaude. Il est recommandé d'installer une barrière physique si des personnes à risques habitent la maison. Pour empêcher l'accès à un foyer ou à un poêle, installez une barrière de sécurité; cette mesure empêchera les tout petits, les jeunes enfants et toute autre personne à risque d'avoir accès à la pièce et aux surfaces chaudes.

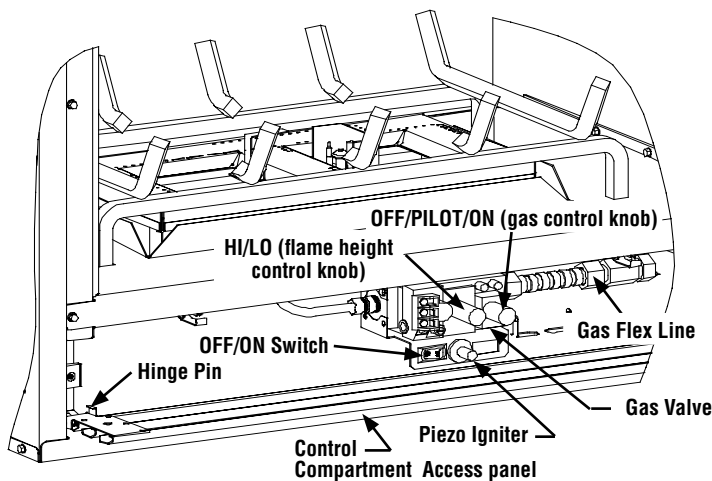

**NOTE:** The gas supply line must be installed in accordance with building codes by a qualified installer approved and/or licensed as required by the locality. In the Commonwealth of Massachusetts, installation must be performed by a licensed plumber or gas fitter.

**Figure 1 - Gas Control Compartment Access**

### Gas Controls/Control Compartment Access

The standard controls for appliance operation are located behind the hinged drop-down panel below the appliance front glass enclosure panel (see **Figure 1**). Optional control switches are also available (see **Page 18 - Remote Wall Switch or Remote Control**).

To open the control compartment access panel, actuate the spring-loaded magnetic catches securing the panel. First, depress the outer top right corner of the panel until the catch "pops" the door free. Then, gently pull the door forward until the left top corner "pops" free, allowing the panel to swing out and down to open.

To ease door closure, depress the catches to place them in their retracted position, then close the door.

On millivolt systems, the piezo igniter, HI/LO flame adjustment knob, and pilot and main gas OFF/ON control knob are located below the glass panel enclosure. The gas valve for electronic systems is also located below the glass enclosure panel. See **Figure 1**.

Operation of millivolt and electronic gas control systems are different. Before lighting and operating your appliance determine if you have a millivolt or electronic appliance. Familiarize yourself with the gas control valve that your appliance uses. Refer to **Figure 1** for access to the gas control valve.

**Millivolt Appliances** - Appliances with Millivolt systems will be fitted with the gas control valve shown in **Figure 2**.

**Electronic Appliances** - Appliances with electronic systems will be fitted with the electronic valve shown in **Figure 3**.

### Millivolt Appliances -

To light millivolt appliances refer to **Figure 1**. Detailed lighting instructions are found on **Pages 22 and 23**. Millivolt appliance lighting instructions may also be found on the pull out lighting instruction labels attached to the gas control valve.

Once the pilot is lit, the main burner may be turned ON and OFF using a wall switch, remote control or unit-mounted rocker switch. To operate: Toggle the switch between its ON and OFF positions.

If your millivolt appliance is equipped with an optional remote switch kit (wall switch or remote control) and the pilot is lit, the appliance main burner may be turned on and off using the optional switch. When using an optional remote switch, turn off the standard OFF/ON switch.

**NOTE:** To prevent excessive resistance in burner circuit (which can cause burner operation problems), only one burner control switch should be wired to valve.



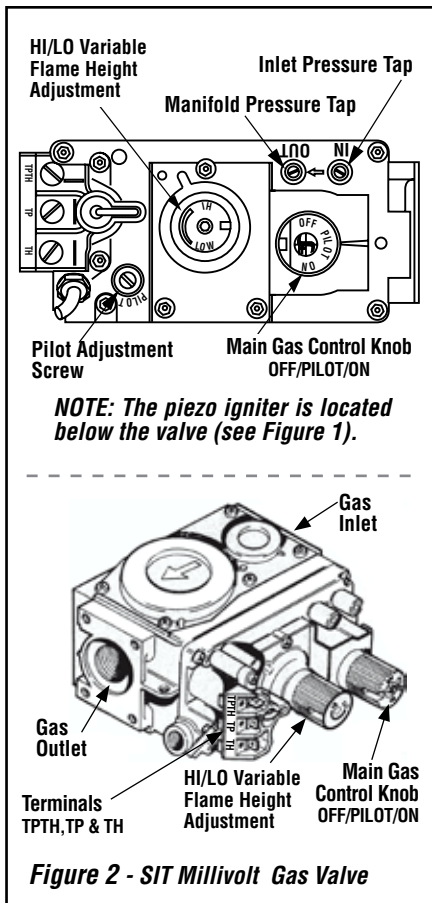

Figure 2 - SIT Millivolt Gas Valve

### Electronic Appliances -

To light electronic appliances refer to the detailed lighting instructions found on **Pages 24 and 25** of these instructions. Electronic appliance lighting instructions may also be found on the pull out lighting instruction labels attached to the gas control valve.

If your electronic appliance is equipped with an optional remote wall switch or remote control kit the appliance main burner may be turned on and off with the wall switch or remote control.

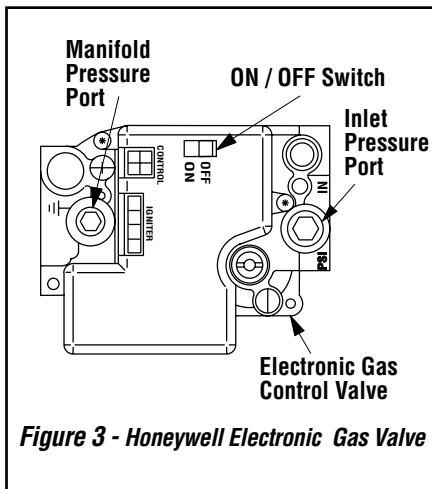

Figure 3 - Honeywell Electronic Gas Valve

### Variable Flame Height Adjustment (Millivolt Appliances only)

All Millivolt appliances are equipped with a variable gas control valve. Flame height for these models may be adjusted through a range between fixed low and high settings while the appliance is in operation. Adjust the flame height as desired after lighting the appliance by rotating the variable adjustment control knob (HI/LO) located on the front of the valve (refer to **Figure 2**).

### VENT OPERATION TEST

A vent operation test is required as part of the installation to verify that proper venting conditions exist and should be done periodically to ensure nothing has changed that would affect proper venting of the appliance.

#### Procedure:

1. ENSURE APPLIANCE IS OFF (PILOT ONLY) AND COOL.
2. Open both latches on one of the glass enclosure doors and slightly prop it open at the bottom (approx. 1/4" gap). See **Figure 6 on Page 12**.
3. Turn on all the exhaust fans in the dwelling (and any other appliances which remove air from the dwelling, such as a furnace or clothes dryer, etc)..
4. Ensure that all the doors and windows in the room where the fireplace is located are closed.
5. Light the appliance (see *Lighting Instructions, Pages 22 to 25*). Adjust flame height to highest setting and operate for approximately 5-10 minutes. Do not leave appliance unattended.
6. Take a smoke producing device and move it along the bottom edge of the glass door (where it is cracked open). If smoke is drawn into the firebox, the vent operation is adequate.

**IF THE SMOKE IS NOT DRAWN INTO THE FIREBOX, TURN THE APPLIANCE OFF AND CALL A QUALIFIED SERVICE TECHNICIAN.**

### SPILL SWITCH OPERATION

#### Manual-Reset (safety limit) Spill Switch

This appliance is equipped with a (*safety limit*) spill switch that is designed to "trip" and disconnect the burner circuit if flue spillage occurs (because of improper venting of combustion products or vent blockage). If, during appliance operation, the burner flame goes out (independently of the burner OFF/ON wall switch), it may be due to the operation of this (*safety limit*) spill switch. If this switch "trips" it will need to be manually reset by pressing the reset button on switch (see **Figure 4**).

#### Procedure to Reset (safety limit) Spill Switch

#### ALLOW APPLIANCE TO COOL COMPLETELY BEFORE ACCESSING AND RESETTING

#### To access the spill switch:

1. Pull off the top louvered panel.
2. the switch (it will click & lock in).

Locate and

The appliance should then relight and remain lit. If this does not occur, **turn off the appliance and call a qualified service technician.**

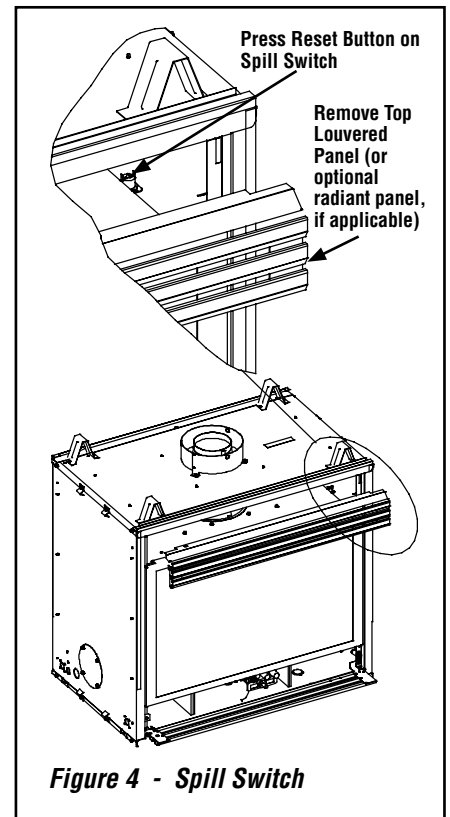

Figure 4 - Spill Switch

## Outside Combustion Air Controls

Many appliances are equipped, when installed, with an outside (make-up air) vent system that is designed to provide the appliance with outside make-up air for combustion when in operation.

The outside air control lever for the outside air system is standard on all appliances but should not be operated if the complete system is not installed. Refer to **Figure 5**. When the complete outside air vent system is installed, the installer will remove the securing screw from the combustion air control lever located on the right side of the fireplace opening.

If the securing screw has not been removed and you have reason to believe that you have a complete outside air system, contact your distributor to have your appliance inspected for the presence of the complete system. **DO NOT** assume that you have this system in place.

### **WARNING**

**Do not operate the shutoff lever unless a complete outside combustion air system has been installed with your appliance.**

To open the outside air shutter, open the bottom control access panel, and pull the outside air control lever all the way out. The outside air shutter should be fully open when the fireplace is in use and completely closed when the fireplace is not being used. Closing it when not in use will prevent outside cold air from entering the dwelling.

The hand operated outside air control lever is located on the right side of the fireplace opening. **See Figure 5**.

To open the outside air , open the bottom control access panel, reach into the gap between the firebox bottom and pull the outside air control lever all the way out.

The outside air shutter should be fully open when the fireplace is in use and completely closed when the fireplace is not being used. Closing it when not in use will prevent outside cold air from entering the dwelling.

Operate the actuator through several cycles including the closed position. Ensuring proper operation and freedom of movement. Return the actuator arm to the closed position.

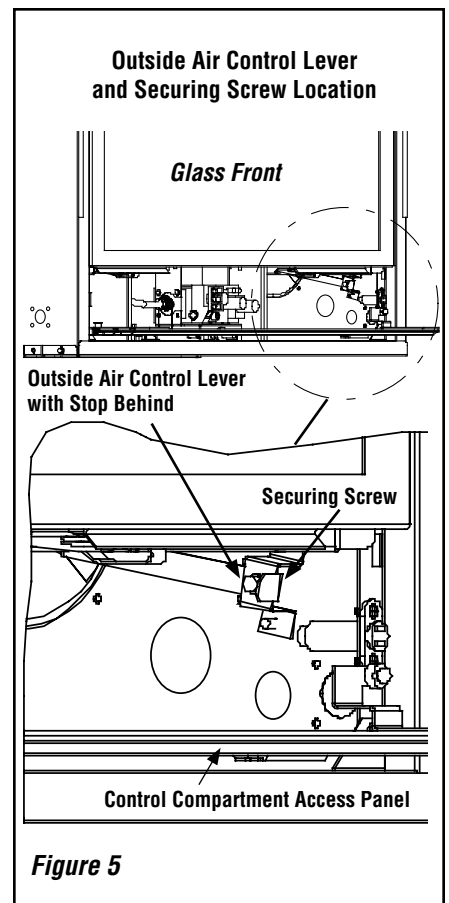

## MAINTENANCE

(See Maintenance Schedule, *Page 26*)

Refer to the maintenance schedule for maintenance tasks, procedures, frequency and by whom they should be performed. Always verify proper operation of the appliance after servicing.



### WARNING

**Turn off gas and electrical power to the fireplace and allow it to cool before cleaning or servicing the appliance.**

**CAUTION:** Wear gloves and safety glasses for protection while doing required maintenance.

Verify proper operation after servicing.

S'assurer que l'appareil fonctionne adéquatement une fois l'entretien terminé.

Always turn off gas to the pilot (millivolt appliances) before cleaning. Before re-lighting, refer to the lighting instructions in this manual. Instructions are also found on a pull-out panel located in the control compartment.

Always keep the appliance area clear and free from combustible materials, gasoline and other flammable vapors and liquids.

### Inspect Venting System

The appliance and venting system should be thoroughly inspected before initial use and at least annually by a qualified service technician (inspection should include ensuring that exhaust passage is unobstructed and vent components are properly assembled and not damaged). **Homeowner must contact a qualified service technician at once if any abnormal condition is observed.**

If the venting system is disassembled for any reason, a qualified service technician should follow vent installation instructions for proper reassembly and proper sealing of the venting system components. However, more frequent periodic inspections and cleanings should be performed by the homeowner.

### Cleaning Glass

(see *Front Glass Enclosure Panel, Removal and Installation* on *Page 10*)

**NOTE:** Clean glass after first two weeks of operation (after Burn-In period is over) and then only when necessary and when the fireplace is cool. Wipe surface with clean, dampened, soft cloth. Follow with a dry, soft towel as desired. Take care not to scratch the glass surface.

**IMPORTANT: Do not use abrasive cleaners on glass. Never clean the glass when it is hot.**

The viewing glass should be cleaned periodically to remove any build-up caused from the following:

- During start-up, it is normal for condensation to form on the inside of the glass (this condensation and fog will usually disappear in a few minutes). The moisture can cause lint, dust and other airborne particles to cling to the glass surface.
- Initial curing of the high temperature paint and burning off of lubricants used in the manufacturing process may result in a film on the glass.
- A white coating may form on the glass as a result of impurities and minerals in the fuel.

It is recommended that the glass be cleaned two or three times during each year, depending on the circumstances present. The following cleaning solutions are approved for use to clean glass:

- Non-ammonia based household cleaner
- 50%-50% mix of white vinegar and water
- Gas fireplace/stove glass cleaner

**Inspect Glass Gasket** - Visually inspect the gasket on the backside of the glass enclosure panels. The gasket surface must be clean, free of irregularities and seated firmly.

### Clean Control Compartment

Keep control compartment clean by vacuuming or brushing at least twice a year. More frequent cleaning may be required due to excessive lint from carpeting, bedding materials, etc. It is important that control compartments, burners and circulating air passageways of the appliance be kept clean.

### Clean Logs And Burner

Carefully remove the logs (use care when handling the fiber logs, as they become quite fragile after curing). Vacuum out any foreign matter (lint, carbon, etc.) on the burner. Ensure the burner ports are "open." Remove any carbon deposits from the under side of the logs using a vacuum cleaner, or a soft bristled brush (i.e. paint brush).

**NOTE:** Improper positioning of logs can create carbon build-up and will alter the performance of the appliance.

### Replacing Logs

If the logs become damaged by accident or improper handling and need replacement, use only the proper replacement logs from manufacturer (see *Page 29* for ordering information).

### Re-Install Embers, Logs and Vermiculite

Carefully follow placement instructions on *Pages 12 to 15*. All logs should fit onto corresponding pins and/or log stoppers. This will ensure a proper flame and safe combustion.

### Inspect Wiring

Refer to wiring diagrams on *Page 17*.

**CAUTION:** Label all wires prior to disconnection when servicing controls. Wiring errors can cause improper and dangerous operation. Verify proper operation after servicing.

**ATTENTION:** Au moment de l'entretien des commandes, étiquetez tous les fils avant de les débrancher. Des erreurs de câblage peuvent entraîner un fonctionnement inadéquat et dangereux.

Inspect and clean all wire connections. Ensure that there is no melting or damage. Inspection should include:

- Terminals at the Valve
- OFF/ON Switch
- (Optional Control Switch) Remote Control or Remote Wall Switch Kit

### Inspect Burner Flame and Pilot Flame Appearance

Periodically do a visual check of the burner flame and the pilot flame. Ensure that the burner flame appearance resembles the flame shown in *Figure 15* and as described in flame Appearance and Sooting on *Page 15*. Refer to *Figures 17 and 18* on *Page 16* for more information about the pilot flame appearance. Contact a qualified service technician at once if any abnormal condition is observed.

### Small Area Paint Touch-up

Only use a factory supplied paint kit for touch-ups. Paint is available at your local Lennox Hearth Products dealer. Never attempt to paint a hot fireplace.

If the surface later becomes stained or marred, it may be lightly sanded and touched up with spray paint.

## Front Glass Enclosure Panel, Removal and Installation

### **! WARNING**

- Do not attempt to substitute the materials used on this door, or replace cracked or broken glass.
- Handle this glass with extreme care! Glass is susceptible to damage – Do not scratch or handle roughly while reinstalling the glass door frame.
- The glass door(s) of this appliance must only be replaced as a complete unit as provided by the manufacturer. Do not attempt to replace broken, cracked or chipped glass separately.
- Do not attempt to touch the front enclosure glass with your hands while the fireplace is in use.

### **! WARNING**

Do not operate appliance with the glass front removed, cracked or broken.

### **! AVERTISSEMENT**

Ne pas utiliser l'appareil si le panneau frontal en verre n'est pas en place, est craqué ou brisé.

### **! WARNING**

Any safety screen or guard removed for servicing the appliance must be replaced prior to operating the appliance.

### **! AVERTISSEMENT**

Tout écran ou protecteur retiré pour permettre l'entretien de l'appareil doit être remis en place avant de mettre l'appareil en marche.

Only doors certified with the appliance shall be used.

Seules des portes certifiées pour cet appareil doivent être utilisées.

**WARNING: DO NOT abuse glass door by striking or slamming shut.**

These fireplaces are designed to operate only with the glass enclosure panels properly installed. Generally the glass enclosure panels should not be removed except to gain access to the components within the firebox, and the appliance may only be operated without the front glass enclosure panel in place for very brief periods of time during initial appliance checkout and adjustment.

### Removing Glass Enclosure Panels (see Figure 6)

1. panel by pulling it out and off.
2. Open the control compartment access panel by actuating the spring-loaded magnetic catches securing the panel (gently depress the outer top corners of the louvered or radiant panel until the catches "pop" the door free, allowing it to swing out and down to the open position).
3. Locate the two (2) latches at the top of the control compartment. To disengage the two latches from the bottom vee-flange of the glass enclosure panel, reach for the handles located towards the back of the latches and pull the handles down toward the front of the appliance.
4. Swing the bottom of the door out and raise it slightly to lift the top flange of the door frame away from the appliance.

### Installing Glass Enclosure Panels (see Figure 6)

1. Visually inspect the gasket on the backside of the panels. The gasket surface must be clean, free of irregularities and seated firmly.
2. Position the glass enclosure panel in front of the firebox opening at a 45 degree angle and engage the top flange over the lip at the top of the firebox opening. **See Figure 6.**
3. Swing the glass enclosure panel down and back. Ensure the gasket seats evenly as the panel draws shut. Engage the Vee-flange at the bottom of the panel with the latches and close the latches to secure the panel.
4. Close the bottom control compartment access panel.

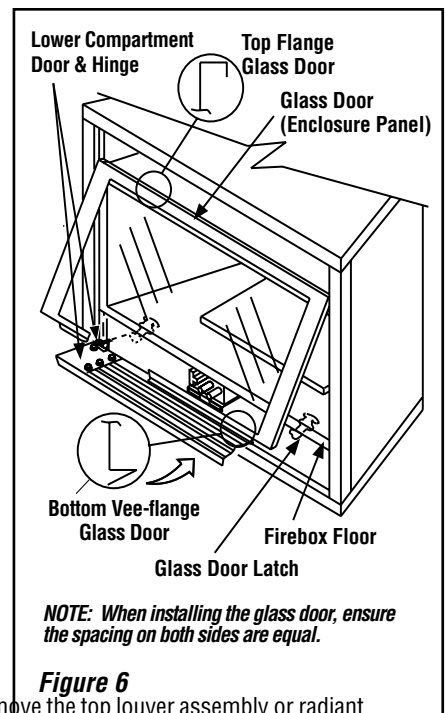

## Installing Grate, Vermiculite, Glowing Embers And Logs

### **! WARNINGS**

- **DO NOT attempt to install the logs until the appliance installation has been completed, the gas line connected and tested for leaks and the initial burner operation has been checked out.**
- **The size and position of the log set was engineered to give the appliance a safe, reliable and attractive flame pattern. Any attempt to use a different log set in the fireplace will void the warranty and will result in incomplete combustion, sooting, and poor flame quality.**
- **Logs get very hot and will remain hot up to one hour after gas supply is turned off. Handle only when logs are cool. Turn off all electricity to the appliance before you install grate, volcanic stone, vermiculite, embers and logs.**

## LOG SET - IDENTIFICATION

LOG SET Catalog Number H3210	
* Item	Description
A	Log, Center
B	Log, Left Rear
C	Log, Left Front
D	Log, Right Rear
E	Log, Top Center
F	Log, Front Center

\* Item "letters" above correspond to photos on right

REFERENCE Firebox Accessories / Parts		
Cat. No.	Model No.	Description
88L53	FGE	Bag of Glowing Embers (1 oz. rockwool)
H6319		Vermiculite, Bag (2 liters)

### **⚠ WARNING**

- This appliance is not designed to burn wood. Any attempt to do so could cause irreparable damage to appliance and prove hazardous to your safety.
- If logs are not installed according to the log installation instructions, flame impingement and improper combustion could occur and result in soot and/or excessive production of carbon monoxide (CO), a colorless, odorless, toxic gas.

#### Glowing Embers

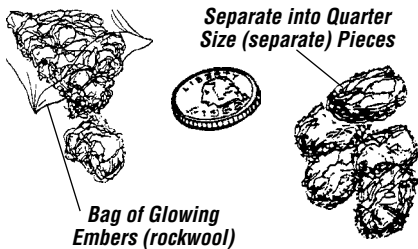
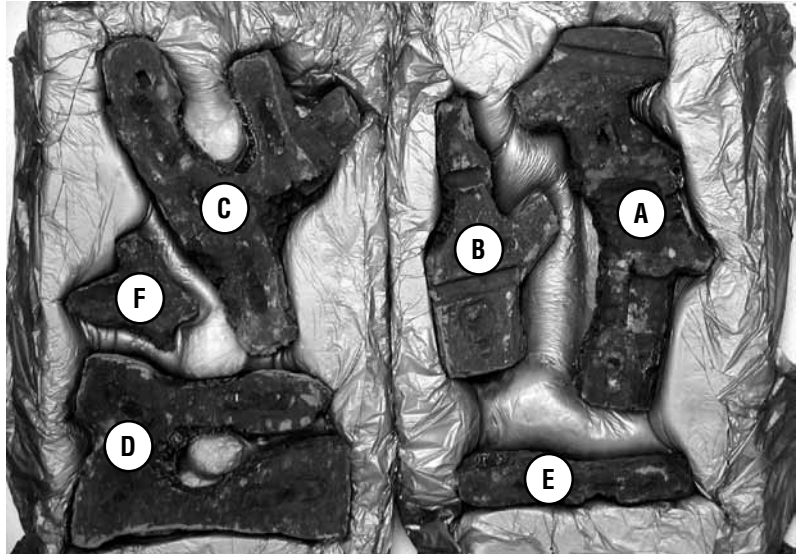
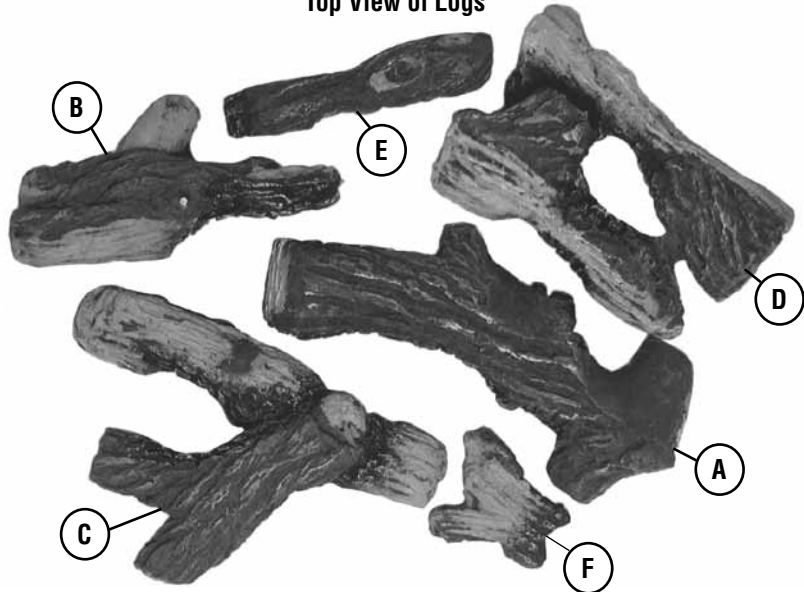

Figure 7

### Bottom View of Logs (in packaging)



### Top View of Logs



### Top View of Logs - Installed

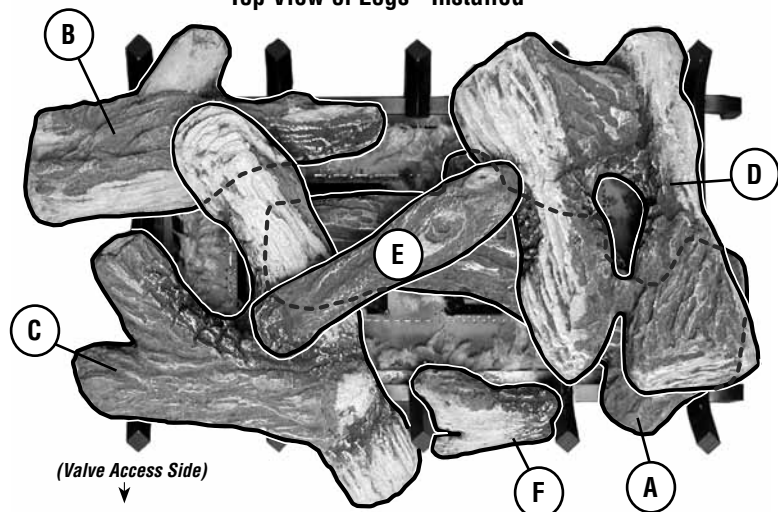



**READ LOG WARNINGS ON PAGE 12 BEFORE PROCEEDING**

1. **Remove front glass enclosure panel** from appliance.
  - a. Open Control Compartment Access Panel (see *Control Compartment Access Instructions* on **Page 8**).
  - b. Remove the glass panel enclosure (see *Removing Glass Enclosure Panel* instructions on **Page 12**).
2. **Remove the following from firebox**, log set, embers (rockwool) and vermiculite. **Handle logs carefully to prevent breakage.**
3. **Ensure the Grate is properly installed** in the firebox with the 4 legs of the grate fitting into the 4 dimples on the firebox floor.
4. **Install Vermiculite** - Place some vermiculite on the firebox floor around the grate (the entire bag of vermiculite will NOT be used). See **Figure 15 on Page 15**. **DO NOT PLACE ANY VERMICULITE ON THE BURNER.**
6. **Placement of Glowing Embers** - Separate the Embers (rockwool) into pieces about the size of a quarter (see **Figure 7**). Keep the pieces fluffed up, not matted. Distribute these pieces over the surface of the burner, as shown in **Figure 8**. Do not use more than is necessary. Ensure that the main burner ports remain uncovered by the ember material.
 

**NOTE:** This appliance is provided with enough Glowing Embers for several applications, do not use all that is in a new bag at one time. For best glowing effect, replace the ember material annually. Replacement Glowing Embers are available (order Catalog Number 88L53).

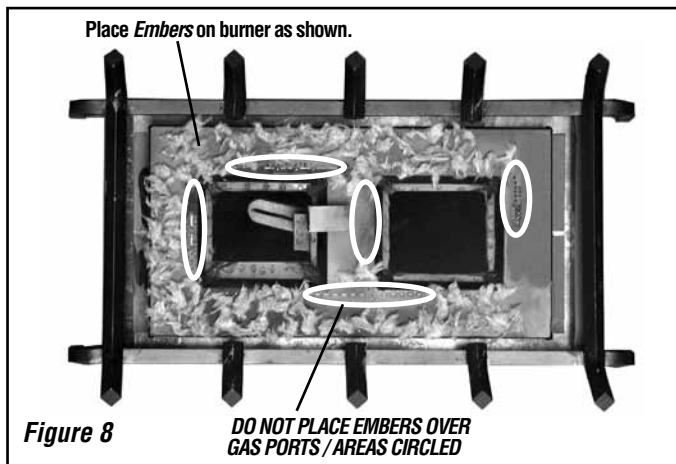

7. Place Log (A) on the grate as shown in **Figure 9**

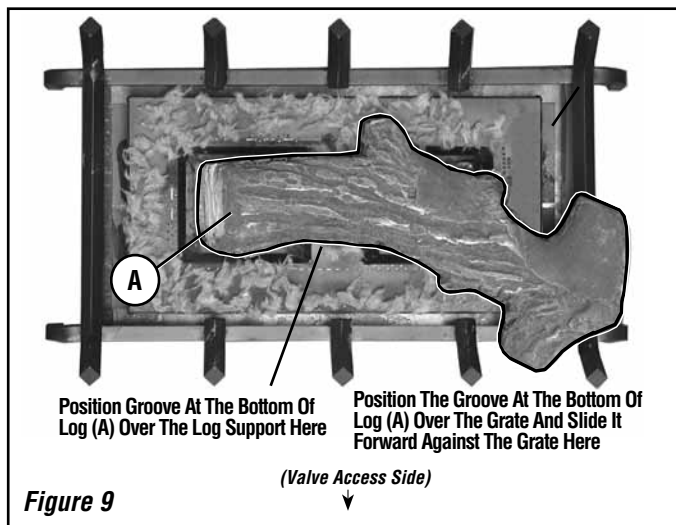

8. Place Log (B) as shown in **Figure 10**.

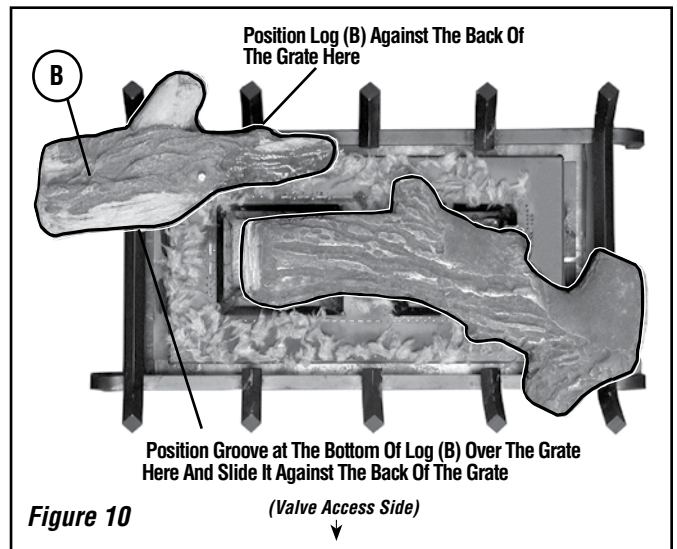

9. Place Log (C) as shown in **Figure 11**.

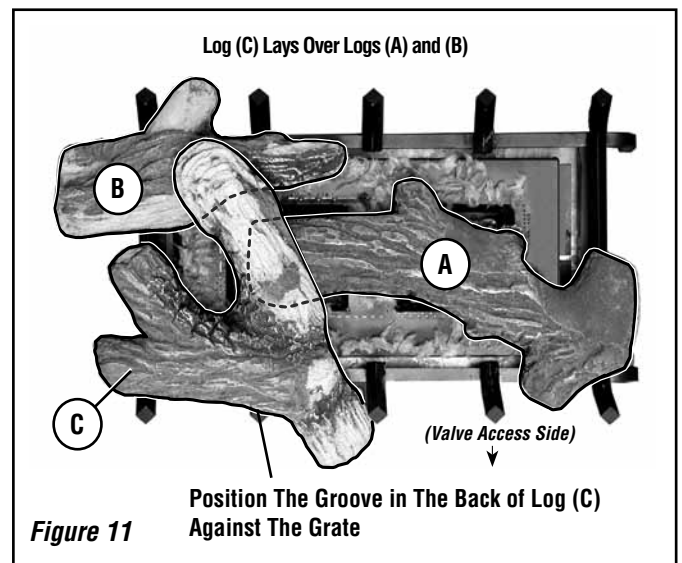

10. Place Log (D) as shown in **Figure 12**.

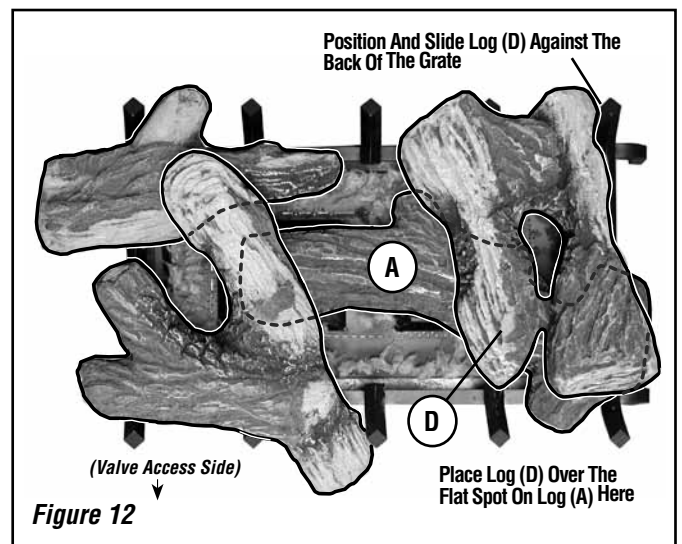

10. Place Log (E) as shown in *Figure 13*.

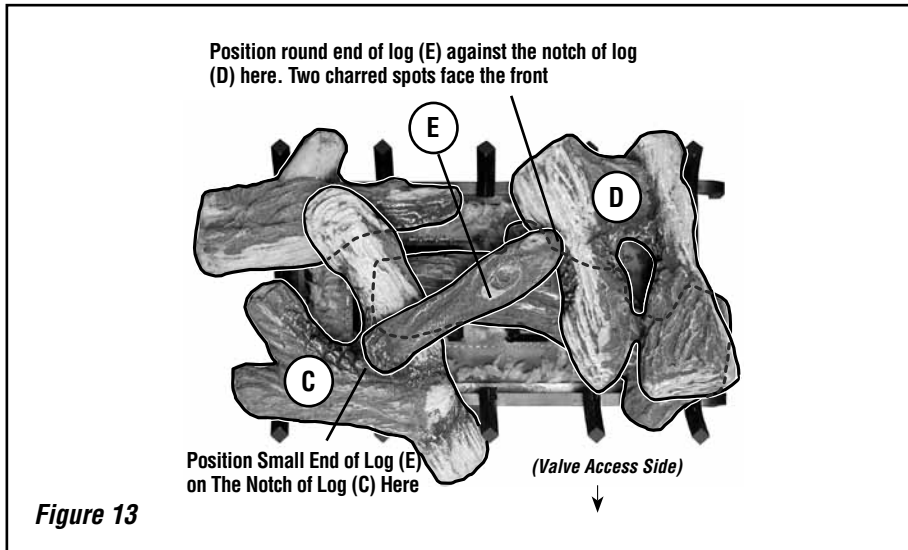

11. Place Log (F) as shown in *Figure 14*.

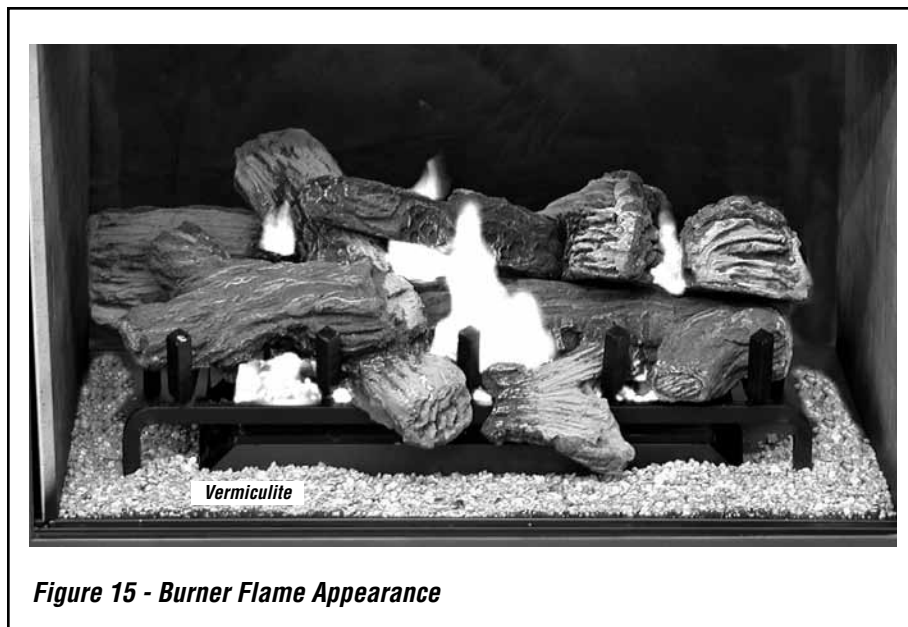
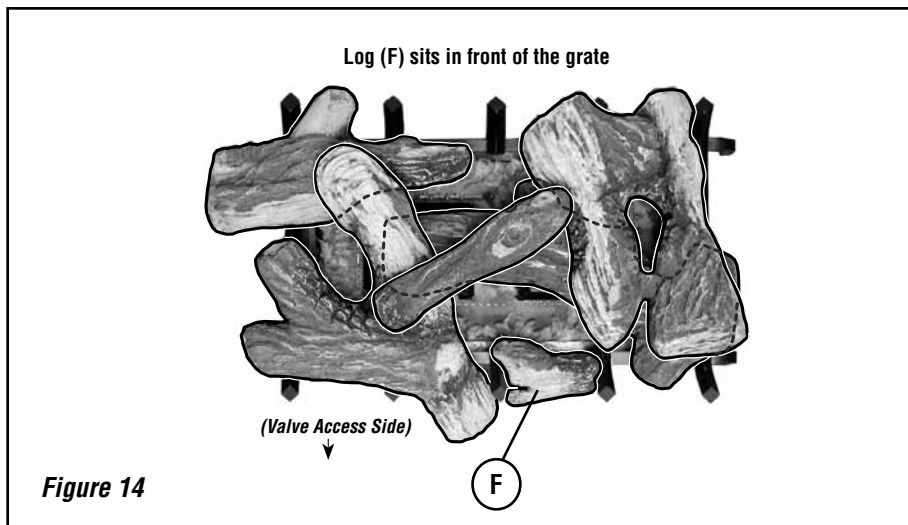

## BURNER ADJUSTMENTS (QUALIFIED TECHNICIANS ONLY)

### Flame Appearance and Sooting

Proper flame appearance is a flame which is blue at the base and becomes yellowish-orange in the body of the flame. When the appliance is first lit, the entire flame may be blue and will gradually turn yellowish-orange during the first 15 minutes of operation. After 15 minutes of operation, if the flame is blue, or if the flame is orange with evidence of sooting (black tip), the air shutter opening may need to be adjusted.

If the air shutter opening is closed too far, sooting may develop. Sooting is indicated by black puffs developing at the tips of very long orange flames. Sooting results in black deposits forming on the logs, appliance inside surfaces and on exterior surfaces adjacent to the vent termination.

Sooting is caused by incomplete combustion in the flames and lack of combustion air entering the air shutter opening. To achieve a warm yellowish-orange flame with an orange body that does not soot, the shutter opening must be adjusted between these two extremes.

#### Air Shutter Adjustment Guidelines

- If there is smoke or soot present, first check the log set positioning to ensure that the flames are not impinging on any of the logs. If the log set is properly positioned and a sooting condition still exists, then the air shutter opening should be increased.
- If there are offsets in the vent system, the air shutter opening may need to be increased.
- An appliance operated with the air shutter opened too far, may have flames that appear blue and transparent. These weak, blue and transparent flames are termed anemic.
- Propane models may exhibit flames which candle or appear stringy. If this is present and persists, adjust the air shutter to a more open position, then operate the appliance for a few more minutes to ensure that the flame normalizes and the flames do not appear sooty.

The following chart is provided to aid you in achieving the correct air shutter adjustment for your installation.

Air Shutter Adjustment Guidelines:		
Amount of Primary Air	Flame Color	Air Shutter Adjustment
If air shutter is closed too far →	Flame will be orange →	Air shutter gap should be increased
If air shutter is open too far →	Flame will be blue →	Air shutter gap should be decreased



## Burner Air Shutter Adjustment Procedure

### **! WARNING**

- Air shutter adjustment should only be performed by a qualified professional service technician.
- Ensure front glass panel are in place and sealed during adjustment.

### **! CAUTION**

- Soot will be produced if the air shutter is closed too much. Any damage due to carboning resulting from improperly setting the air shutter is not covered under the warranty.
- The air shutter door and nearby appliance surfaces are hot. Exercise caution to avoid injury while adjusting flame appearance.

1. Locate adjustment rod and adjust air shutter to the standard setting as shown in **Figure 16** (adjustment rod is located in the lower control area). **NOTE:** Rotating the adjustment rod counterclockwise decreases air and clockwise increases air.
2. Light appliance (follow lighting procedure on lighting label in control compartment or see care and operation instructions manual).
3. Allow the burner to operate for at least 15 minutes while observing the flame continuously to ensure that the proper flame appearance has been achieved (see **Figure 15**). If the following conditions are present, adjust accordingly.
  - If flame appears weak or sooty, adjust the air shutter, incrementally, to a more open position until the proper flame appearance is achieved.
  - If flame stays lowered blue, adjust the air shutter, incrementally, to a more closed position until the proper flame appearance is achieved.
4. Leave the control knob (off/pilot/on) in the ON position and the burner OFF/ON switch OFF (and remote switches, if applicable).
5. When satisfied that the burner flame appearance is normal, close the lower control compartment door.

Main Burner Factory Air Shutter Opening Setting - All Models		
Model	Natural Gas	Propane Gas
MPB35ST	1/8" 3.2mm	1/4" 6.4mm

Ref. Air shutter Patent:  
U.S. Pat. 5,553,603

Adjustment Rod Positions  
(when viewed from above)

**Figure 16**

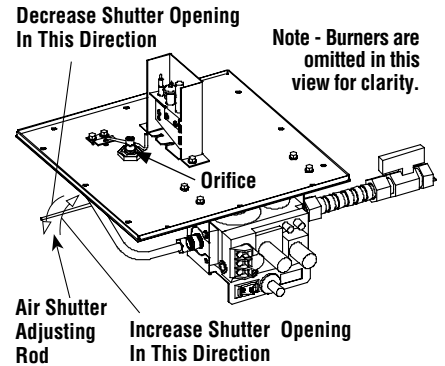

### Millivolt Appliance Checkout

The pilot flame should be steady, not lifting or floating. Flame should be blue in color with traces of orange at the outer edge.

The top 3/8" (10 mm) at the pilot generator (thermopile) and the top 1/8" min (tip) of the quick drop out thermocouple should be engulfed in the pilot flame. The flame should project 1" (25 mm) beyond the hood at all three ports. See **Figure 17**.

To light the burner, refer to the lighting instructions on **Page 22**.

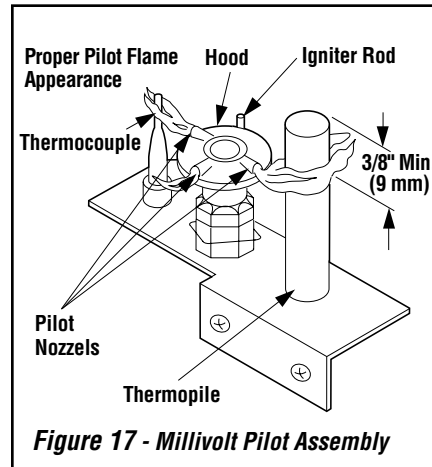

**Figure 17 - Millivolt Pilot Assembly**

### Electronic Appliance Checkout

To light the burner, refer to the lighting instructions on **Page 24**. Ensure the igniter lights the pilot. The pilot flame should engulf the flame sensor as shown in **Figure 18**.

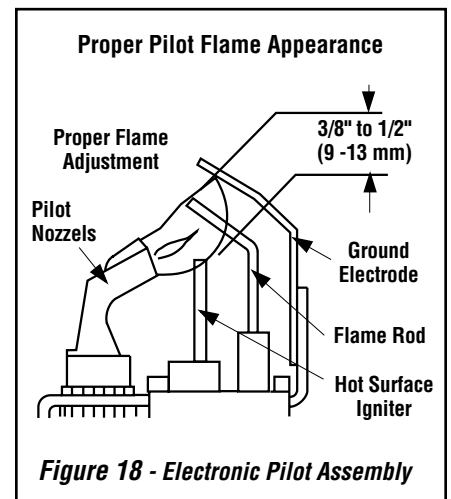

**Figure 18 - Electronic Pilot Assembly**

## WIRING DIAGRAMS

Wiring diagrams are provided here for reference purposes only. This information is also provided on schematics attached directly to the appliance on a pullout panel located within the control compartment.

**CAUTION: LABEL ALL WIRES PRIOR TO DISCONNECTION WHEN SERVICING CONTROLS. WIRING ERRORS CAN CAUSE IMPROPER AND DANGEROUS APPLIANCE OPERATION.**

**ATTENTION: AU MOMENT DE L'ENTRETIEN DES COMMANDES, ÉTIQUETEZ TOUS LES FILS AVANT DE LES DÉBRANCHER. DES ERREURS DE CÂBLAGE PEU-VENT ENTRAÎNER UN FONCTIONNEMENT INADÉQUAT ET DANGEREUX.**

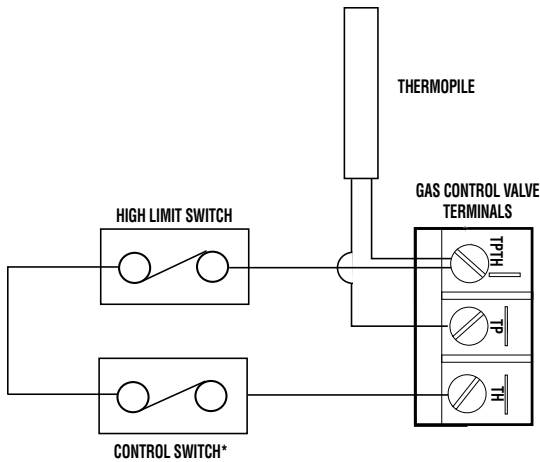

If any of the original wire as supplied must be replaced, it must be replaced with type AWM 105° C - 18 gage wire.

VERIFY PROPER OPERATION AFTER SERVICING.

Schematic Representation Only

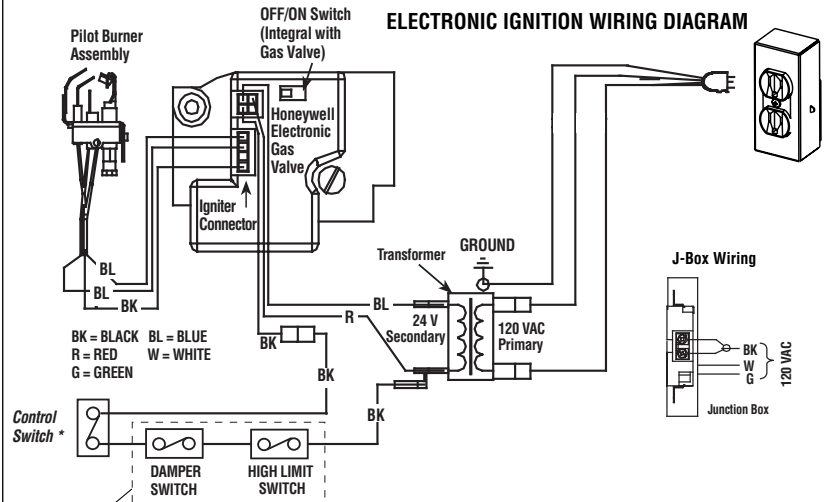

B-Vent appliances only - one or both of these switches must be factory installed in series as shown. If wires to these switches are replaced, wires must be Type AWM 200°C - 18 gage wire ONLY.

### NOTES:

1. If any of the original wire as supplied must be replaced, use Type AWM 105°C - 18 gage wire ONLY.
2. 120 VAC, 60 Hz - Less than 3 Amps.

**CAUTION:** label all wires prior to disconnection when servicing controls. Wiring errors can cause improper and dangerous operation. Verify proper operation after servicing.

\* Control Switches: Wall On/Off Switch or Timer, Unit Mounted On/Off Switch, or Remote Control Switch. If an optional control switch is installed, turn the appliance-mounted ON/OFF burner control switch to the OFF position.

## REPLACEMENT PARTS

A complete parts list is found at the end of this manual. Use only parts supplied from the manufacturer.

With proper care and maintenance, your appliance will provide many years of enjoyment. If you should experience any problem, first refer to the troubleshooting guide in this manual. If problem persists, contact your Lennox Hearth Products dealer or distributor.

Normally, all parts should be ordered through your LennoxHearthProducts distributor or dealer.

Parts will be shipped at prevailing prices at time of order.

When ordering repair parts, always give the following information:

1. The model number of the appliance.
2. The serial number of the appliance.
3. The part number.
4. The description of the part.
5. The quantity required.
6. The installation date of the appliance.

If you encounter any problems or have any questions concerning the installation or application of this system, please contact your dealer or distributor.

## LENNOX HEARTH PRODUCTS

1508 Elm Hill Pike, Suite 108

Nashville, TN 37210

visit us at [www.LennoxHearthProducts.com](http://www.LennoxHearthProducts.com)

1-800-655-2008

## PRODUCT REFERENCE INFORMATION

We recommend that you record the following important information about your fireplace. Please call Lennox Hearth Products for the phone number of your nearest Lennox Hearth Products dealer who will answer your questions or address your concerns.

Your Fireplace's Model Number \_\_\_\_\_

Your Fireplace's Serial Number \_\_\_\_\_

The Date On Which Your Fireplace Was Installed \_\_\_\_\_

The Type of Gas Your Fireplace Uses \_\_\_\_\_

Your Dealer's Name \_\_\_\_\_

NOTE: DIAGRAMS & ILLUSTRATIONS ARE NOT TO SCALE.

## ACCESSORY COMPONENTS

Product Reference Information			
Cat. No.	Model	Ship. Weight	Ship. Volume
H7808	MPB35ST-NM-B	220 lbs	46W x 26D x 43H (30 cu.ft).
H7809	MPB35ST-PM-B	220 lbs	46W x 26D x 43H (30 cu.ft).
H7810	MPB35ST-NE-B	220 lbs	46W x 26D x 43H (30 cu.ft).

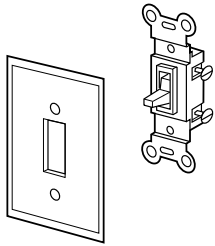

### OFF/ON Wall Switch Kit

The OFF/ON wall switch kit may be used to control the operation of the fireplace burner. Install the OFF/ON wall switch in a convenient location near the fireplace.

White Wall Switch Kit		
Cat. No.	Model No.	Description
85L87	FWSK	OFF/ON Wall Switch Kit



### Manual or up to 3 hr Countdown Timer modes

- LCD display
- Displays room temp. in °F or °C
- Flame icon and low battery indicator
- Includes batteries
- Wall clip included
- Receiver may be wall mounted or placed in the control compartment
- Includes white face plate
- Flame icon
- Low battery indicator
- Batteries included

Remote, Two Button, Timer, On/Off Or Timer Mode		
Cat. No.	Model No.	Description
H8860	RC-S-1	Remote Control



### Wall Control

- 4-button timer with 30/60/120/OFF minutes
- Wall surface mounted
- Connects to wall switch wire
- Perfect for rental and resort applications

Wall Switch, Countdown Timer		
Cat. No.	Model No.	Description
H8863	WS-S-TMR	Wall Switch



### Cost Effective Solution

- Simple On/Off operation
- Works with millivolt and low voltage electronic ignition controls

Kit includes:  
Remote and Receiver

G-Fire Remote, Simple On/Off		
Cat. No.	Model No.	Description
H8840	KIT-RC-G-FIRE	Remote Control

## ACCESSORY COMPONENTS

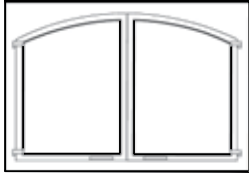

**Arch Design**

**Arch Pane Design**

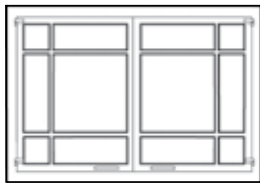
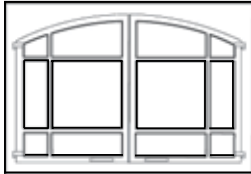

**Square Pane Design**

### Style View Screen Doors -

These Style View screen doors come in three beautiful styles. They are easy to install and will not require hardware to attach them to the standard glass door frame. The screens prevent direct contact with the hot glass surface. The door includes heavy duty magnet door latches and functional twin-pane screen doors.

Arch Pane Design Kits		
H0930	APD35C	35" Arch Pane Doors, Black
H0932	APD35SP	35" Arch Pane Doors, Satin Pew.

Arch Design Kits		
Cat. No.	Model	Description
H0858	AD35C	35" Arch Doors, Black
H0860	AD35SP	35" Arch Doors, Satin Pewter

Square Pane Design Kits		
H0962	SPD35C	35" Sq. Pane Doors, Black
H0964	SPD35SP	35" Sq. Pane Doors, Satin Pew.

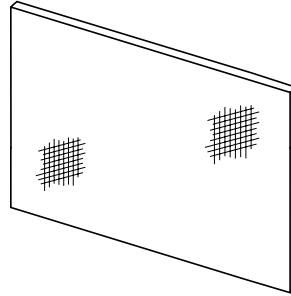

35" Barrier Screen Kits		
Cat. No.	Model No.	Description
26M48	HG35M	35" Barrier Screen Kit

(ref. Form # 750,101M)

### Barrier Screen Kits

These barrier screen kits create a barrier to prevent direct contact with the hot glass. The screen panel affixes directly to the glass enclosure panel.

Order 2 if a set is desired (for front face and rear face glass surfaces).



### Bag of Glowing Embers Bag of Volcanic Stone

Replacement ember materials or volcanic stone are available for use with these appliances. Order kits as part of the periodic maintenance of the appliance.

Decorative Firebox Accessories		
Cat. No.	Model No.	Description
88L53	FGE	Bag of Glowing Embers (1 oz. rockwool)
80L42	FDVS	Bag of Decorative Volcanic Stone

(FDVS ref. Form #750,010M)

## ACCESSORY COMPONENTS

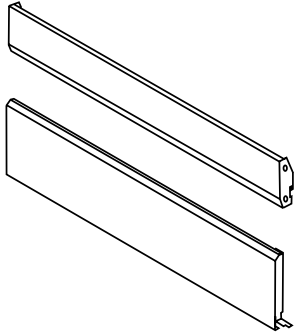

### Clean Face Panel Kits

Clean faced panel kits are available to convert the standard louvered fireplaces to radiant models which are more suited for finishing around the firebox opening with non-combustible materials, such as tile.

Clean Face Black Radiant Panel Kits		
Cat. No.	Model No.	Description
88L36	RAD35C-2	Clean Face Panel Kit

(ref. Form # 504,223M)

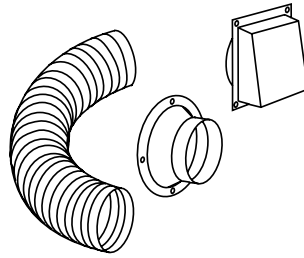

### Outside Air Kits Models FOAK-4 and FOAK-4LD

Outside Air kits are available with duct (FOAK-4) and without duct (FOAK-4LD) for use if outside combustion air is required or desired. If model FOAK-4LD is used it must be used in conjunction with locally purchased, non-combustible Class 1 or Class 0 flexible duct.

Outside Combustion Air Kits		
Cat. No.	Model No.	Description
81L87	FOAK-4	Combustion Air Kit (with duct)
81L88	FOAK-4LD	Combustion Air Kit (without duct)



### Touch-Up Paint Kit

Repair of minor scratches and discoloration of the appliance black painted surfaces may be accomplished with the touch-up paint kit.

Touch-Up Paint Kits		
Cat. No.	Model No.	Description
90L73	FTPK-B	Touch-Up Paint (Black)

(TPK-C ref. Form # 504,216M)

## ACCESSORY COMPONENTS

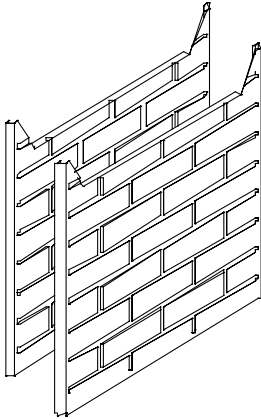

### Brickaded Panel Liner Kit

The brickaded liner kits include ceramic panels as shown here. The panels have brick-like features in relief.

Brickaded Wall Liner Kits		
Cat. No.	Model No.	Description
H3207	MBLK-35ST	Interior Brick Liner Kit

(ref. Form # 750,160M)

### *Sunrise Style (upper grille shown)*



### Decorative Grille Kits

These decorative grilles are offered in two attractive finishes and fit on the face of the appliance in place of the standard louvers.

Cat. No.#	Model	Description	Model Series
H3565	SUGK35C	35" Black	UPPER GRILLE KITS SUNRISE
H3567	SUGK35SP	35" Satin Pewter	

H3569	SLGK35C	35" Black	LOWER GRILLE KITS SUNRISE
H3571	SLGK35SP	35" Satin Pewter	

(ref. Form # 750,202M)

## LIGHTING INSTRUCTIONS – MILLIVOLT GAS VALVE



### FOR YOUR SAFETY READ BEFORE LIGHTING

**WARNING:** If you do not follow these instructions exactly, a fire or explosion may result causing property damage, personal injury or loss of life.

A. This appliance has a pilot which must be lighted by a piezo igniter. When lighting the pilot, follow these instructions exactly.

B. BEFORE LIGHTING smell all around the appliance area for gas. Be sure to smell next to the floor because some gas is heavier than air and will settle on the floor.

#### WHAT TO DO IF YOU SMELL GAS:



- Do not try to light any appliance.
- Do not touch any electric switch; do not use any phone in your building.

- Immediately call your gas supplier from a neighbor's phone. Follow the gas supplier's instructions.
- If you cannot reach your gas supplier, call the fire department.

C. Use only your hand to push in or turn the gas control knob. Never use tools. If the knob will not push in or turn by hand, don't try to repair it, call a qualified service technician. Force or attempted repair may result in a fire or explosion.

D. Do not use this appliance if any part has been under water. Immediately call a qualified service technician to inspect the appliance and to replace any part of the control system and any gas control which has been under water.

### LIGHTING INSTRUCTIONS

1. STOP! Read the safety information above on this label.
2. (If applicable) Set the thermostat to lowest setting. Turn wall on/off switch, unit mounted on/off switch or remote control switch "OFF."
3. Turn OFF all electric power to the appliance.
4. Access the control compartment.
5. Push in gas control knob slightly and turn clockwise  to "OFF."  
NOTE: Knob cannot be turned from "PILOT" to "OFF" unless knob is pushed in slightly. Do Not force.
6. Wait five (5) minutes to clear out any gas. Then smell for gas, including near the floor. If you smell gas, STOP! Follow "B" in the safety information above on this label. If you don't smell gas, go to the next step.
7. Find pilot - located in firebox on the same plane as the top of the burner.
8. Turn knob on gas control counterclockwise  to "PILOT."
9. Push in control knob all the way and hold in. Immediately light the pilot by triggering the piezo igniter (pushing the button) until pilot lights. Continue to hold the control knob in for about 1-1/2 minutes after the pilot is lit. Release knob and it will pop back up. Pilot should remain lit. If it goes out, repeat steps 5 through 9.
  - If knob does not pop up when released, stop and immediately call your service technician or gas supplier.

- If the pilot will not stay lit after several tries, turn the gas control knob to "OFF" and call your service technician or gas supplier.
10. Turn gas control knob counterclockwise  to "ON."
  11. Close control compartment.
  12. (If applicable) Turn on all electrical power to the appliance.
  13. (If applicable) Set thermostat to desired setting. Turn wall on/off switch, unit mounted on/off switch or remote control switch "ON."

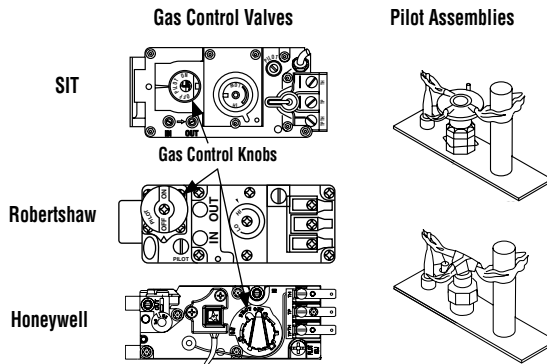

### TO TURN OFF GAS TO APPLIANCE

1. (If applicable) Set the thermostat to lowest setting. Turn wall on/off switch, unit mounted on/off switch or remote control switch "OFF."
2. Turn OFF all electric power to the appliance, if service is to be performed.
3. Access the control compartment.
4. Push in gas control knob slightly and turn clockwise  to "OFF." Do not force.
5. Close the main line gas shut-off valve.
6. Close control compartment.



# WARNING



**HOT GLASS WILL CAUSE BURNS.  
DO NOT TOUCH GLASS UNTIL COOLED.  
NEVER ALLOW CHILDREN TO TOUCH GLASS.**



## INSTRUCTIONS D'ALLUMAGE – VANNE GAZ MILLIVOLT



### POUR PLUS DE SÉCURITÉ, LIRE AVANT D'ALLUMER

**AVERTISSEMENT.** Quiconque ne respecte pas à la lettre les instructions dans la présente notice risque de déclencher un incendie ou une explosion entraînant des dommages, des blessures ou la mort.

A. Cet appareil est muni d'une veilleuse qui doit être allumée avec un allumeur piézo-électrique. Respectez les instructions ci-dessous à la lettre.

B. **AVANT L'ALLUMAGE:** Avant d'allumer la veilleuse, reniflez tout autour de l'appareil pour déceler une odeur de gaz. Reniflez près du plancher, car certains gaz sont plus lourds que l'air et peuvent s'accumuler au niveau du sol.

**QUE FAIRE SI VOUS SENTEZ UNE ODEUR DE GAZ :**

- Ne pas tenter d'allumer d'appareil.
- Ne touchez à aucun interrupteur ; ne pas vous servir des téléphones se trouvant dans le bâtiment.

- Appelez immédiatement votre fournisseur de gaz depuis un voisin. Suivez les instructions du fournisseur.
- Si vous ne pouvez rejoindre le fournisseur, appelez le service des incendies.

C. Ne pousser ou tourner la manette d'admission du gaz qu'à la main. Ne jamais employer d'outil à cette fin. Si la manette reste coincée, ne tentez pas de la réparer; appelez un technicien qualifié. Quiconque tente de forcer la manette ou de la réparer peut provoquer une explosion ou un incendie.

D. N'utilisez pas cet appareil s'il a été plongé dans l'eau, même partiellement. Faites inspecter l'appareil par un technicien qualifié et remplacez toute partie du système de contrôle et toute commande qui ont été plongés dans l'eau.

### INSTRUCTIONS D'ALLUMAGE

1. **ARRÊTEZ !** Lisez les instructions de sécurité sur la portion supérieure de cette étiquette.
2. (Si applicable) Réglez le thermostat à la température la plus basse. Tournez l'interrupteur murale, l'interrupteur sur l'unité ou le contrôle à distance à "OFF."
3. Coupez l'alimentation électrique de l'appareil.
4. Accédez au compartiment de contrôle.
5. Enfoncez légèrement le bouton de réglage du gaz et tournez-le dans le sens des aiguilles d'une montre jusqu'à la position d'arrêt "OFF".  
Remarque: Il est impossible de tourner le bouton de "PILOT" à "OFF" à moins qu'il ne soit légèrement enfoncé. Ne le forcez pas.
6. Attendez cinq (5) minutes pour laisser échapper tout le gaz. Reniflez tout autour de l'appareil, y compris près du plancher, pour déceler une odeur de gaz. Si vous sentez une odeur de gaz, **ARRÊTEZ !** Passez à l'étape B des instructions de sécurité sur la portion supérieure de cette étiquette. S'il n'y a pas d'odeur de gaz, passez à l'étape suivante.
7. Trouver le pilote – Situé dans l'âtre sur la même surface que le dessus du brûleur.
8. Tournez le bouton de contrôle sur la valve à gaz dans le sens antihoraire vers "Pilot".
9. Enfoncez le bouton de réglage jusqu'au fond et gardez-le enfoncé. Allumez immédiatement la veilleuse en déclenchant l'allume-gaz à étincelle (en poussant le bouton) jusqu'à ce que la veilleuse s'enflamme. Continuez de tenir le bouton de réglage enfoncé pendant environ 90 secondes après l'allumage de la veilleuse. Relâchez le bouton et il sortira subitement. La veilleuse devrait rester allumée. Si elle s'éteint, répétez les étapes 5 à 8 inclusivement.

- Si la manette ne se soulève pas d'elle-même lorsqu'on la relâche, arrêter et appeler immédiatement un technicien qualifié ou le fournisseur de gaz.
  - Si la veilleuse ne reste pas allumée après plusieurs tentatives, réglez la manette d'admission du gaz à la position OFF et appelez un technicien qualifié ou le fournisseur de gaz.
10. Tournez le bouton de réglage du gaz en sens inverse des aiguilles d'une montre jusqu'à sa position de marche "ON".
  11. Fermer le compartiment de contrôle.
  12. (Si applicable) Mettez l'appareil sous tension.
  13. (Si applicable) Réglez le thermostat à la température désirée. Tournez l'interrupteur murale, l'interrupteur sur l'unité ou le contrôle à distance à "ON."

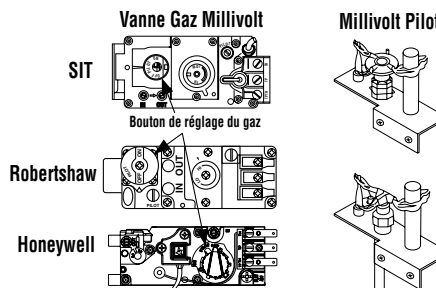

### COMMENT COUPER L'ADMISSION DE GAZ DE L'APPAREIL

1. (Si applicable) Réglez le thermostat à la température la plus basse. Tournez l'interrupteur murale, l'interrupteur sur l'unité ou le contrôle à distance à "OFF."
2. Coupez l'alimentation électrique de l'appareil s'il faut procéder à l'entretien.
3. Accédez au compartiment de contrôle.
4. Enfoncez légèrement le bouton de réglage du gaz et tournez-le dans le sens des aiguilles d'une montre jusqu'à la position d'arrêt "OFF". Ne forcez pas le bouton.
5. Fermer la valve de gaz principale.
6. Fermer le compartiment de contrôle.



# AVERTISSEMENT



**UNE SURFACE VITRÉE CHAUDE PEUT CAUSER DES BRÛLURES.  
LAISSER REFROIDIR LA SURFACE VITRÉE AVANT D'Y TOUCHER.  
NE PERMETTEZ JAMAIS À UN ENFANT DE TOUCHER LA SURFACE VITRÉE.**

## LIGHTING INSTRUCTIONS — ELECTRONIC



### FOR YOUR SAFETY READ BEFORE OPERATING

**WARNING:** If you do not follow these instructions exactly, a fire or explosion may result causing property damage, personal injury or loss of life.

A. This appliance is equipped with an ignition device which automatically lights the pilot. Do not try to light the pilot by hand.

B. **BEFORE OPERATING** smell all around the appliance area for gas. Be sure to smell next to the floor because some gas is heavier than air and will settle on the floor.

#### WHAT TO DO IF YOU SMELL GAS:

- Do not try to light any appliance.
- Do not touch any electric switch; do not use any phone in your building.

- Immediately call your gas supplier from a neighbor's phone. Follow the gas supplier's instructions.
- If you cannot reach your gas supplier, call the fire department.

C. Use only your hand to actuate the gas valve ON/OFF switch. Never use tools. If the switch will not move by hand, don't try to repair it, call a qualified service technician. Force or attempted repair may result in a fire or explosion.

D. Do not use this appliance if any part has been under water. Immediately call a qualified service technician to inspect the appliance and to replace any part of the control system and any gas control which has been under water.

### OPERATING INSTRUCTIONS

1. **STOP!** Read the safety information above on this label.
2. (If applicable) Set the thermostat to lowest setting. Turn wall on/off switch, unit mounted on/off switch or remote control switch "OFF."
3. Turn OFF all electric power to the appliance.
4. This appliance is equipped with an ignition device which automatically lights the pilot. Do not try to light the pilot by hand.
5. Access the control compartment.
6. Turn the ON/OFF switch, on the gas control valve, to "OFF." Do not force.
7. Wait five (5) minutes to clear out any gas. Then smell for gas, including near the floor. If you smell gas, **STOP!** Follow "B" in the safety information above on this label. If you don't smell gas, go to the next step.
8. Turn the ON/OFF switch, on the gas control valve, to "ON." Do not force.
9. Turn on all electrical power to the appliance.
10. (If applicable) Set thermostat to desired setting. Turn wall on/off switch, unit mounted on/off switch or remote control switch "ON."
11. Close control compartment.
12. If the appliance will not operate, follow the instructions "To Turn Off Gas To Appliance" and call your service technician or gas supplier.

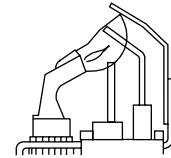
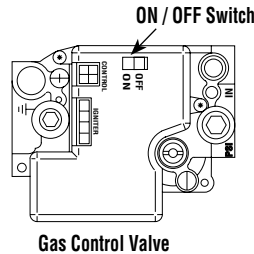

Electronic Pilot Assembly

### TO TURN OFF GAS TO APPLIANCE

1. (If applicable) Set the thermostat to lowest setting. Turn wall on/off switch, unit mounted on/off switch or remote control switch "OFF."
2. Turn "OFF" all electric power to the appliance, if service is to be performed.
3. Access the control compartment.
4. Turn the ON/OFF switch, on the gas control valve, to "OFF." Do not force.
5. Close the main line gas shut-off valve.
6. Close control compartment.



# WARNING



**HOT GLASS WILL CAUSE BURNS.  
DO NOT TOUCH GLASS UNTIL COOLED.  
NEVER ALLOW CHILDREN TO TOUCH GLASS.**



**POUR PLUS DE SÉCURITÉ LIRE AVANT DE METTRE EN MARCHÉ**

**AVERTISSEMENT.** Quiconque ne respecte pas à la lettre les instructions dans la présente notice risque de déclencher un incendie ou une explosion entraînant des dommages, des blessures ou la mort.

- A. Cet appareil est muni d'un dispositif d'allumage qui allume automatiquement la veilleuse. Ne tentez pas d'allumer la veilleuse manuellement.
- B. **AVANT DE FAIRE FONCTIONNER**, reniflez tout autour de l'appareil pour déceler une odeur de gaz. Reniflez près du plancher, car certains gaz sont plus lourds que l'air et peuvent s'accumuler au niveau du sol.
- QUE FAIRE SI VOUS SENTEZ UNE ODEUR DE GAZ :**
  - Ne pas tenter d'allumer d'appareil.
  - Ne touchez à aucun interrupteur; ne pas vous servir des téléphones se trouvant dans le bâtiment.
  - Appelez immédiatement votre fournisseur de gaz depuis un voisin. Suivez les instructions du fournisseur.
- Si vous ne pouvez rejoindre le fournisseur, appelez le service des incendies.
- C. N'utilisez que votre main pour manipuler l'interrupteur "ON/OFF" de la valve à gaz. N'utilisez jamais d'outils. Si l'interrupteur ne bouge pas manuellement, n'essayez pas de le réparer. Communiquez immédiatement avec un technicien de service qualifié. Toute tentative pour forcer l'interrupteur ou le réparer, risquerait de provoquer un incendie ou une explosion.
- D. N'utilisez pas cet appareil s'il a été plongé dans l'eau, même partiellement. Faites inspecter l'appareil par un technicien qualifié et remplacez toute partie du système de contrôle et toute commande qui ont été plongés dans l'eau.

**INSTRUCTIONS DE MISE EN MARCHÉ**

1. **ARRÊTEZ !** Lisez les instructions de sécurité sur la portion supérieure de cette étiquette.
2. (Si applicable) Réglez le thermostat à la température la plus basse. Tournez l'interrupteur murale, l'interrupteur sur l'unité ou le contrôle à distance à "OFF."
3. Coupez l'alimentation électrique de l'appareil.
4. Cet appareil est muni d'un dispositif d'allumage qui allume automatiquement la veilleuse. Ne tentez pas d'allumer la veilleuse manuellement.
5. Accédez au compartiment de contrôle.
6. Tournez l'interrupteur sur la valve de contrôle à "OFF." Ne pas forcer.
7. Attendre cinq (5) minutes pour laisser échapper tout le gaz. Reniflez tout autour de l'appareil, y compris près du plancher, pour déceler une odeur de gaz. Si vous sentez une odeur de gaz, **ARRÊTEZ !** Passez à l'étape B des instructions de sécurité sur la portion supérieure de cette étiquette. S'il n'y a pas d'odeur de gaz, passez à l'étape suivante.
8. Tournez l'interrupteur sur la valve de contrôle à "ON." Ne pas forcer.
9. Mettez l'appareil sous tension.
10. (Si applicable) Réglez le thermostat à la température désirée. Tournez l'interrupteur murale, l'interrupteur sur l'unité ou le contrôle à distance à "ON."
11. Fermer le compartiment de contrôle.
12. Si l'appareil ne se met pas en marche, suivez les instructions intitulées « Comment couper l'admission de gaz de l'appareil » et appelez un technicien qualifié ou le fournisseur de gaz.

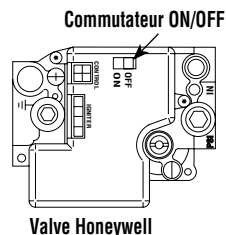

**COMMENT COUPER L'ADMISSION DE GAZ DE L'APPAREIL**

1. (Si applicable) Réglez le thermostat à la température la plus basse. Tournez l'interrupteur murale, l'interrupteur sur l'unité ou le contrôle à distance à "OFF."
2. Coupez l'alimentation électrique de l'appareil s'il faut procéder à l'entretien.
3. Accédez au compartiment de contrôle.
4. Tournez l'interrupteur sur la valve de contrôle à "OFF." Ne pas forcer.
5. Fermer la valve de gaz principale.
6. Fermer le compartiment de contrôle.



**AVERTISSEMENT**



**UNE SURFACE VITRÉE CHAUDE PEUT CAUSER DES BRÛLURES.  
LAISSER REFROIDIR LA SURFACE VITRÉE AVANT D'Y TOUCHER.  
NE PERMETTEZ JAMAIS À UN ENFANT DE TOUCHER LA SURFACE VITRÉE.**

## MAINTENANCE SCHEDULE

### Annually (Before the onset of the Burning Season)

MAINTENANCE TASK	ACCOMPLISHING PERSON	PROCEDURE
Inspect/Clean Burner, Logs and Controls	Qualified Service Technician	Inspect valve and ensure it is properly operating. Check piping for leaks. Vacuum the control compartment, fireplace logs and burner area.
Check Flame Patterns and Flame Height	Qualified Service Technician	Refer to <b>Figure 15</b> on <b>Page 15</b> and verify the flame pattern and height displayed by the appliance conforms to the picture. Flames must not impinge on the logs. Ensure flames are steady (not lifting or floating).
Inspect/Clean Pilot and Burner	Qualified Service Technician	Refer to <b>Figure 17</b> and <b>Figure 18</b> on <b>Page 16</b> . Remove any surface build-up on pilot and burner assembly. Wipe the pilot nozzles, igniter/flame rod and hood. Ensure the pilot flame engulfs the flame sensor as shown.
Check Vent System	Qualified Service Technician	Inspect the vent system at the top and at the base (within the firebox) for signs of blockage or obstruction. Look for any signs of dislocation or deterioration of the vent components. NOTE: Inspect wall straps or plumbers's tape to ensure it is secure and in place.
Appliance Checkout	Qualified Service Technician	Perform the appropriate appliance checkout procedure detailed in this manual.
Replacing Glowing Embers	Homeowner/Qualified Service Technician	Remove old ember materials (rockwool) and vacuum the ember placement area. Place new embers as described in <b>Step 6</b> on <b>Page 14</b> .

### Periodically (After the Burning Season)

MAINTENANCE TASK	ACCOMPLISHING PERSON	PROCEDURE
Clean Firebox Interior	Homeowner	Carefully remove logs, glowing embers (rockwool), and vermiculite. Vacuum out interior of the firebox. Clean firebox walls and log grate. Replace logs, embers (rockwool) and vermiculite as detailed in this manual (see <b>Pages 12 through 15</b> ).
Check Flame Patterns and Flame Height	Homeowner	Refer to <b>Figure 15</b> on <b>Page 15</b> and verify the flame pattern and height displayed by the appliance conforms to the picture. Flames must not impinge on the logs.
Check Vent System	Homeowner	Inspect the vent system at the top and at the base (within the firebox) for signs of blockage or obstruction. Look for any signs of dislocation of the vent components.
Clean Front Glass Enclosure Panel	Homeowner	Clean as necessary following the directions provided in this manual. <b>DO NOT TOUCH OR ATTEMPT TO CLEAN GLASS WHILE HOT.</b>

## TROUBLESHOOTING

**NOTE:** Before troubleshooting the gas control system, Ensure external gas shut off valve, located at gas supply inlet, (and wall switch, iff applicable), is in the "ON" position.

**Important:** Valve system troubleshooting should only be accomplished by a qualified service technician.

### TROUBLESHOOTING GUIDE - MILLIVOLT GAS CONTROL SYSTEM

SYMPTOM	POSSIBLE CAUSES	CORRECTIVE ACTION
<p>1. Spark igniter will not light pilot after repeated triggering of igniter button.</p> <p><b>WARNING: if the pilot will not light after 1 minute of attempting, wait for at least 5 minutes for gas to clear before attempting again.</b></p>	A. Defective igniter (no spark at electrode).	Check for spark at electrode and pilot; if no spark and electrode wire is properly connected, replace igniter.
	B. Defective or misaligned electrode at pilot (spark at electrode).	Using a match, light pilot. If pilot lights, turn off pilot and trigger the igniter button again. If pilot lights, an improper gas mixture caused the bad lighting and a longer purge period is recommended. If pilot will not light – check gap at electrode and pilot – should be 1/8" to have a strong spark. If gap measures 1/8", replace pilot (see <b>Figure 17 on Page 16</b> ).
	C. Gas supply pressure errant.	Check inlet gas pressure. It should be within the limits as marked on the rating plate.
	D. Pilot orifice plugged.	Clean or replace pilot orifice.
<p>2. Pilot will not stay lit after carefully following the lighting instructions.</p>	A. Defective pilot generator (thermocouple).	Check pilot flame, it must impinge on thermocouple (see <b>Figure 17 on Page 16</b> ). Clean and/or adjust pilot for maximum flame impingement on thermocouple. Ensure that the connection between the valve and thermocouple are tight and secure.
<p>3. Pilot burning, no gas to burner, Valve knob "ON," and the (standard) burner OFF/ON switch is "ON." Read important note below.</p> <p><b>IMPORTANT NOTE: If an optional *remote switch is used for burner operation, if the standard burner OFF/ON switch is still installed on appliance it must be in the "OFF" position.</b></p> <p><b>* Optional remote switch kits - wall switch or timer, or remote control.</b></p>	A. Wall switch or wires defective.	Check wall switch and wires for proper connections. Jumper wire across terminals at wall switch, if burner comes on, replace defective wall switch. If okay, jumper wires across wall switch wires at valve, if burner comes on, wires are faulty or connections are bad.
	B. Thermopile may not be generating sufficient millivolts.	Check thermopile with millivolt meter. Take reading at thermopile terminals of gas valve. Should read 325 millivolts minimum with optional wall switch "OFF." Replace faulty thermopile if reading is below specified minimum.
	C. Plugged burner orifice.	Check burner orifice for blockage and remove.
	D. OFF/ON Switch & *Remote Switch are in the "ON" position resulting in excessive resistance.	When turning on the burner using a *remote switch, ensure that the standard OFF/ON switch is in the "OFF" position. If both switches are in the ON position, it may result in excessive resistance (& millivolt drainage) and the burner may not come on.
<p>4. Frequent pilot/burner outage problem.</p>	A. Pilot flame may be too low or blowing (high) causing the pilot/valve safety to drop out.	Clean and/or adjust pilot flame for maximum flame impingement on thermocouple (see <b>Figure 17 on Page 16</b> ).

### TROUBLESHOOTING GUIDE - ELECTRONIC IGNITION SYSTEM

SYMPTOM	POSSIBLE CAUSES	CORRECTIVE ACTION
<p>1. Burner will not light.</p>	A. Faulty Valve System.	See <b>Page 28</b> .
	B. "OFF/ON" or wall switch defective.	Disconnect the two black wires from the wire nuts. Test switch(s) for continuity with a multimeter. If continuity is not indicated, switch(s) is defective and must be replaced.  <b>NOTE:</b> Before replacing "OFF/ON" switch, Ensure to check wiring for loose connections or broken wires and repair as needed.
<p>2. Burners come "ON," then turns "OFF."</p>	A. Burner orifice plugged.	Check main burner orifice(s) for blockage. Clean or replace.
	B. Obstructed vent system.	Check vent system for obstructions.

# TROUBLESHOOTING THE ELECTRONIC IGNITION SYSTEM

## START

- Turn Off Gas Supply.
- Ensure Valve Switch Is In ON Position.
- Disconnect Control Harness.

## Insert A

### End View of Control Harness Connector

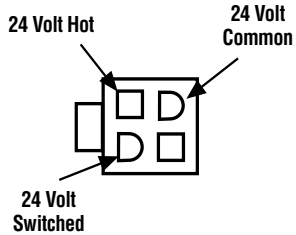

Check For Damaged or Missing Terminals in Connector

## Insert B

### Igniter Terminals

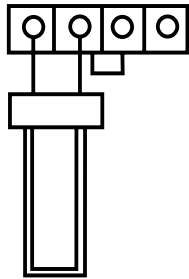

## CHECK

- Line voltage power
- Low voltage transformer
- Limit controller
- Wiring

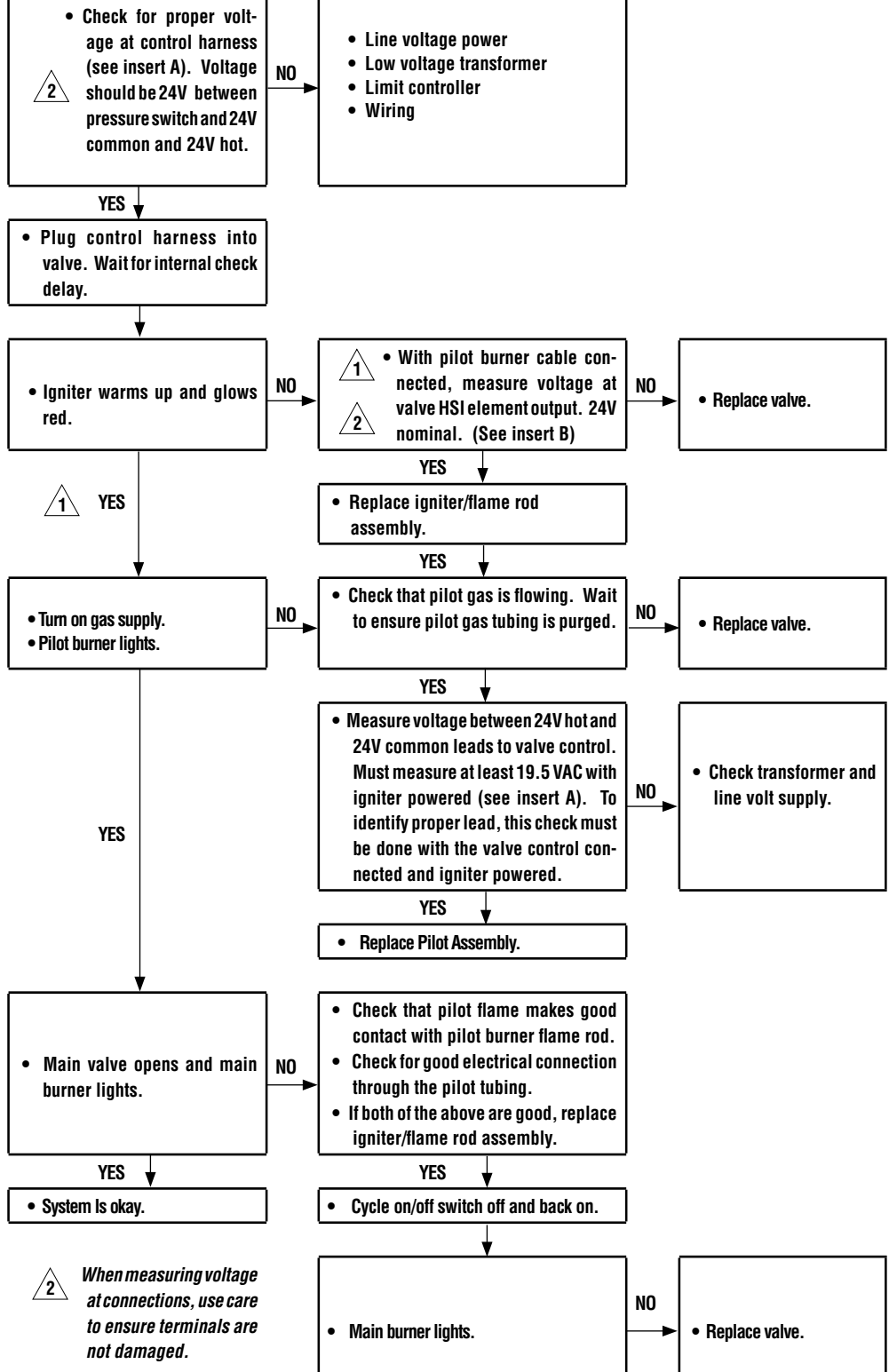

**1** Igniter will cycle off and back on once during the 90 second ignition trial. All voltage measurements must be taken while the igniter is powered.

**2** When measuring voltage at connections, use care to ensure terminals are not damaged.

## REPLACEMENT PARTS LIST - MPB35ST

Item	Part/Cat. No.	Qty	Description	Where Used
<b>SIT Millivolt Only</b>				
1	H6286	1	Gas Train Assembly, NG, MV	MPB35ST-NM
1	H6284	1	Gas Train Assembly, LP, MV	MPB35ST-PM
<b>Honeywell Electronic Only</b>				
2	H6285	1	Gas Train Assembly, NG, Electr.	MPB35ST-NE
3	H6592	1	Transformer	MPB35ST-NE & MPB35ST-PE
<b>Misc. Replacement Parts</b>				
4	H6281	2	Side Panels	All
5	H6282	1	Burner, Pan	All
6	H6283	1	*Electrical kit	All
7	97K51	2	Eyebrow Panel	All
8	93L32	1	Flex Line Gas Connector, FFGC	All
9	H6554	2	Glass Enclosure Assembly	All
10	88L53		Glowing Embers (1 oz.), FGE	All
11	H6287	1	Grate Assembly	All
12	69L21	4	Latch, Glass Enclosure Panel	All

Item	Part/Cat. No.	Qty	Description	Where Used
<b>Misc. Replacement Parts</b>				
14	H3210	1	Log Set	All
15	H6337	2	Louver Assembly, Upper Black	All
16	H6344	1	Louver Assembly, Lower, Black (valve access side)	All
17	H6288	1	Louver Assembly, Lower, Black	All
18	69L31	2	Magnet, Latch, Spring-Loaded	All
19	H3699	2	Magnet	All
20	H6350	8	Nailing Flange	All
21	12L15	2	Nameplate, Lennox	All
22	24M10	1	Orifice, Burner, NG, #37 (.104")	MPB35ST-NM & MPB35ST-NE
22	42M79	1	Orifice, Burner, LP, 1.55mm (.061")	MPB35ST-PM & MPB35ST-PE
23	10K86	1	Piezo Igniter (order wire separately - 56L21)	MPB35ST-NM & MPB35ST-PM
24	27K30	1	Switch, OFF/ON, Rocker	All
10	H6319	1	Vermiculite, Bag (2 liters)	All

Contact a Lennox Hearth Products dealer to obtain any of these parts. Never use substitute materials. Use of non-approved parts can result in poor performance and safety hazards.

### **WARNING**

Failure to position the parts in accordance with these diagrams or failure to use only parts specifically approved with this appliance may result in property damage or personal injury.

### **AVERTISSEMENT**

Risque de dommages ou de blessures si les pièces ne sont pas installées conformément à ces schémas et ou si des pièces autres que celles spécifiquement approuvées avec cet appareil sont utilisées.



# REPLACEMENT PARTS - MPB35ST

**NOTE:** Ordering information for Volcanic Stone, Glowing Embers and Touch-up Paint can be found on **Page 16**.

\* Electrical Outlet Kit consists of a junction box, 2 screws, an receptacle outlet, an OFF/ON rocker switch and a snap bushing. **NOTE:** All the components in the electrical kit will Not be used by every model.

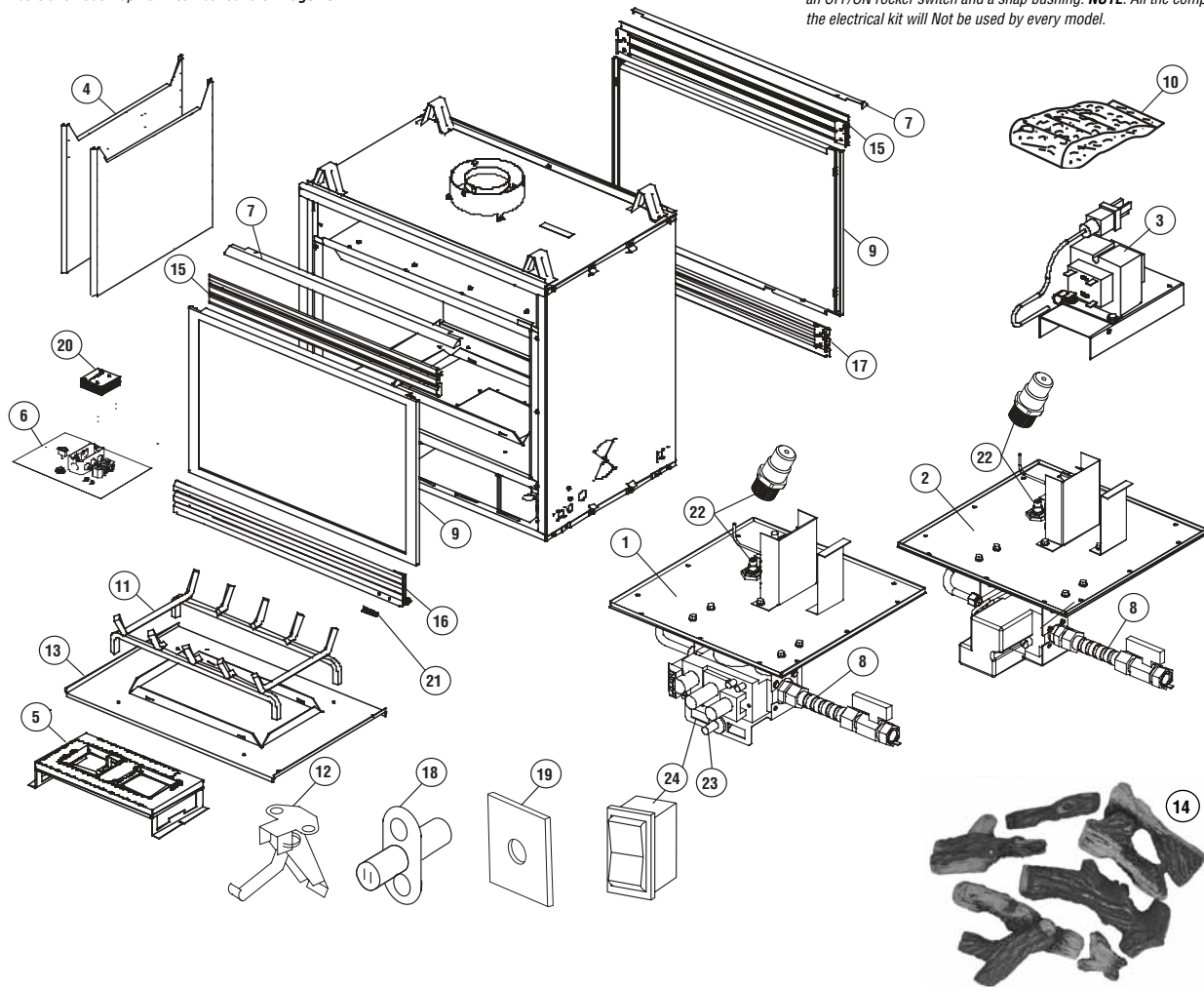

**NOTES**

---

Lennox Hearth Products reserves the right to make changes at any time, without notice, in design, materials, specifications, prices and also to discontinue colors, styles and products. Consult your local distributor for fireplace code information.

LENNOX®, the LENNOX design, DAVE LENNOX, the image of DAVE LENNOX and other related LENNOX marks are registered or common law trademarks of Lennox Industries Inc. and are used with permission.

Printed in U.S.A. © 2005 Lennox Hearth Products LLC

**P/N 875024M Rev. E 04/2013**



**1508 Elm Hill Pike, Suite 108 • Nashville, TN 37210**