



INSTALLATION AND OPERATION MANUAL

Free-Standing EPA Certified Wood-Burning Stoves

Save These Instructions
For Future Reference

P/N 900112-00, Rev. A, 04/2015

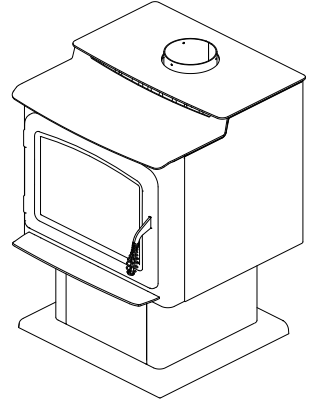

Wood-Burning Stoves Models Grandview™ GV230 and GV300

With Innovative Thermal Fin Technology (TFT™)



GV230 - Report # 14-182

GV300 - Report # 14-194

A French manual is available upon request. Order P/N 900111-00.

Ce manuel d'installation est disponible en français, simplement en faire la demande. Numéro de la pièce 900111-00.

This appliance must be properly installed and operated in order to prevent the possibility of a house fire. Please read this entire installation and operation manual before installing and using your wood stove. Failure to follow these instructions could result in property damage, bodily injury or even death. Contact your local building or fire officials to obtain a permit and information on any installation requirements and inspection requirements in your area.



www.nficertified.org

We recommend that our woodburning hearth products be installed and serviced by professionals who are certified in the U.S. by the National Fireplace Institute® (NFI) as NFI Woodburning Specialists or who are certified in Canada by Wood Energy Technical Training (WETT).



WARNING

- **Hot! Do not touch!** The glass and surfaces of this appliance will be hot during operation and will retain heat for a while after shutting off the appliance. Severe burns may result.
- **Carefully supervise children** in the same room as appliance.

CONGRATULATIONS!

When you purchased your new wood stove, you joined the ranks of thousands of individuals whose answer to their home heating needs reflects their concern for aesthetics, efficiency and our environment. We extend our continued support to help you achieve the maximum benefit and enjoyment available from your new wood stove.

Thank you for selecting an Innovative Hearth Products, LLC (IHP) wood stove as the answer to your home supplemental heating needs.

TABLE OF CONTENTS

Using This Manual	2
Important Safety Information.....	3
Testing Information.....	4
Draft Requirements.....	4
Selecting the Proper Venting System.....	4
Chimney Height Requirements.....	5
Negative Pressure Warning	5
Clearances	6-8
Clearances to Combustibles - GV230	7
Clearances to Combustibles - GV300	8
Alcove, Floor Protection - GV230.....	9
Alcove, Floor Protection - GV300.....	10
Specifications	11
Typical Installation Figures.....	12
Chimney Installation	13
Manufactured (mobile) Home Installations	13
Chimney - Wall Pass-Through Requirements	14
Leg Installation	15
Pedestal Installation.....	15

Attaching Stove to Manufactured Home Floor - GV230	16
Outside Combustion Air Kit Installation	17
Brick and Baffle Board Installation - GV230	18
Brick and Baffle Board Installation - GV300	19
For Mobile Home Installs	20
Post Installation Checks.....	20
Paint Curing	21
Burn-In Period	21
Operating Hints	21
Door Operation	21
Starting and Maintaining a Fire	22-23
Fuel	23
Getting the Most Out of Your Stove	24
Maximizing Your Stove's Overall Efficiency.....	24
Achieving Clean, Long Burns	24
Blower Operation (optional kit)	25
Do's and Don'ts.....	26
Smoke Detector Recommended.....	26
Carbon Monoxide Monitor Recommended	26
Maintenance.....	27-28
Troubleshooting	29
Replacement Parts Lists	30-31
Accessories.....	32
Warranty	33
Product Reference Information.....	34

USING THIS MANUAL

Please read and carefully follow all of the instructions found in this manual. Please pay special attention to the safety instructions provided in this manual.

PRODUCT IS SUBJECT TO CHANGE WITHOUT NOTICE

IMPORTANT SAFETY AND WARNING INFORMATION

READ THIS MANUAL IN ITS ENTIRETY AND UNDERSTAND THESE RULES TO FOLLOW FOR SAFETY.

1. When this room heater is not properly installed, a house fire may result. To reduce the risk of fire, follow the installation instructions. Contact local building or fire officials about restrictions and installation inspection requirements in your area.
2. Wear gloves during installation to avoid injury from sharp edges on the stove and/or its parts.
3. This unit is designed and engineered to burn only dry, well-seasoned wood. Burning wet wood will greatly reduce the stove's efficiency, produce excessive amounts of smoke and can cause dangerous chimney fires due to creosote build-up.
4. Before opening the door, the draft control must be fully open to avoid possible combustion flash (ignition of hot volatile gases as the door is opened).
5. Never use gasoline, gasoline-type lantern fuel, kerosene, charcoal lighter fluid, or similar liquids to start or 'freshen up' a fire in this heater. Keep all such liquids well away from the heater while it is in use. **DO NOT USE CHEMICALS OR FLUIDS TO START THE FIRE.**
6. While burning, fuel utilizes oxygen from the air in the room. Be sure to allow an adequate amount of fresh air into the room where the stove is burning.
7. The outside surface of the stove will be hot while burning properly and can set items like clothing and curtains on fire. Keep furnishings and other combustible materials away from the stove. Using the heat from the stove to dry wet clothing can be hazardous if clothes are placed too near the surface of the stove.
8. **HOT WHILE IN OPERATION. KEEP CHILDREN, CLOTHING, FURNISHINGS AND COMBUSTIBLE MATERIAL A CONSIDERABLE DISTANCE AWAY. CONTACT MAY CAUSE SKIN BURNS.** Do not allow children to play near the stove without close supervision. Do not touch the stove while it is burning. Use extreme caution while the unit is in use. Surface temperatures become dangerously hot and can cause serious burns.
9. Do not allow anyone to operate the stove who is not familiar with the operating instructions.
10. Attempts to achieve heat output rates that exceed stove design specifications can result in permanent damage to the stove. Never leave your stove unattended on high burn rates. This may cause overfiring. Overfiring the stove may cause a house fire. If the stove glows, you are overfiring.
11. Keep a water hose or hand-operated fire extinguisher close for safety.
12. **Smoke Detectors** - Since there are always several potential sources of fire in any home, we recommend installing smoke detectors. If possible, install the smoke detector in a hallway adjacent to the room (to reduce the possibility of occasional false activation from the heat produced by the stove). If your local code requires a smoke detector be installed within the same room, you must follow the requirements of your local code. Check with your local building department for requirements in your area.
13. Inspect your chimney at least once a month during the burning season to check for soot and creosote accumulations. Any accumulations over 1/8" thick should be removed by a professional chimney sweep. Do not attempt to burn out heavy creosote accumulations with a hot fire. If large accumulations are occurring, review your burning procedures.
14. If a creosote fire should develop, the fire department should be called immediately and then attempts should be made to control the fire until assistance arrives. If a "runaway" fire should develop causing over-heating of the stove, the door and draft regulators should be closed immediately. The fire should die down once deprived of oxygen. After a severe chimney fire, the complete chimney system should be checked before further use.
15. **Do Not Use Grate Or Elevate Fire - Build Wood Fire Directly On Hearth** (firebrick). Do not use andirons or other methods of supporting the fuel.
16. Please read this entire manual before you install and use your new room heater. Failure to follow instructions may result in property damage, bodily injury, or even death.
17. Check all local building and safety codes before installation. The installation instructions and appropriate code requirements must be followed exactly and without compromise. In the absence of local codes the following standards and codes must be followed.
18. In the U.S.A, install in accordance with the National Fire Protection Association's Code, NFPA 211, Standards for Chimneys, Fireplaces, Vents and Solid-Fuel-Burning Appliances, or similar regulations, may apply to the installation of a Solid-Fuel-Burning appliance in your area. In Canada, the guideline is established by the CSA Standard, CAN/CSA-B365-M93, Installation Code for Solid-Fuel-Burning Appliances and Equipment.
19. **DO NOT CONNECT TO OR USE IN CONJUNCTION WITH ANY AIR DISTRIBUTION DUCTWORK UNLESS SPECIFICALLY APPROVED FOR SUCH INSTALLATIONS.**
20. **WARNING: BURNING IMPROPER FUEL (I.E. CHARCOAL) CAN RESULT IN CARBON MONOXIDE POISONING, WHICH MAY LEAD TO DEATH!**
21. **Carbon Monoxide Poisoning** - Early signs of carbon monoxide poisoning resemble the flu with headaches, dizziness, or nausea. If you have these signs, get fresh air at once! Have the heater inspected by a qualified service technician. Some people are more affected by carbon monoxide than others. These include pregnant women, people with heart or lung disease or anemia, those under the influence of alcohol, and those at high altitudes.
22. Failure to use manufacturer provided parts, variations in techniques and construction materials or practices other than those described in this manual may create a fire hazard and void the limited warranty.
23. Do not make any make-shift compromises during installation. Any modification or alteration may result in damage to the appliance or dwelling and will void the warranty, certification and listings of this unit.
24. These appliances are designed as supplemental heaters. Therefore, it is advisable to have an alternate heat source when installed in a dwelling.
25. **Do Not Overfire** - If Heater or Chimney Connector Glows, You Are Overfiring.
26. **DO NOT CONNECT THIS UNIT TO A CHIMNEY FLUE SERVING ANOTHER APPLIANCE.**
27. **DO NOT BURN GARBAGE OR FLAMMABLE FLUIDS SUCH AS GASOLINE, NAPHTHA OR ENGINE OIL.**

TESTING INFORMATION

This manual describes the installation and operation of the Grandview™ 230 and Grandview 300 non-catalytic wood heaters. This heater meets the U.S. Environmental Protection Agency's emissions limits for wood heaters sold on or after July 1, 1990. This heater has been developed, tested and constructed in accordance with the requirements of UL 1482, ULC S627 and HUD standards and is listed by PFS Corporation. It has been approved for residential, mobile home and alcove installations.

Model	Emission Rate	Heat Output	EPA Estimated Efficiency
GV230	3.6 g/hr	11,214 - 28,216 btu/hr	63%
GV300	3.1 g/hr	10,249 - 29,181 btu/hr	63%

DRAFT REQUIREMENTS

This appliance is dependent upon a properly functioning chimney for optimum performance. It is a high efficiency appliance that loses much less heat up the chimney than older appliances and fireplaces. For this reason it is important to match the stove to the chimney. The chimney has two functions:

1. It draws combustion air into the appliance (without air, no fuel will burn) and
2. It exhausts combustion by-products. Your new stove is what is known as a "natural draft" appliance.

The appliance depends solely on the natural draft of the chimney system to draw combustion air into the unit. Draft is the force that moves air from the appliance up into the chimney. The amount of draft in your chimney depends on the length of the chimney, local geography, nearby obstructions and other factors. Too much draft may cause excessive temperatures in the appliance (overfiring). Slow or inadequate draft equals poor combustion and possible smoking problems. The following are some conditions that may contribute to poor chimney draft:

1. A chimney too large for your appliance.
2. A chimney with not enough height to produce adequate draft.
3. A chimney with excessive height (this may allow exhaust to cool too much before exiting, which will stall the rate the exhaust exits).
4. Offsets in the venting system are too restrictive (see *Chimney Guidelines*).

Inadequate draft will cause the appliance to leak smoke into the room through the stove and the chimney connector joints.

Excessive draft may cause an uncontrollable burn or a glowing red stove or chimney part.

Overfiring Damage - If the heater or chimney connector glows, you are overfiring. Other symptoms may include: Cracking, warping or burning out of components, plated accessories may turn color, stove glass may develop a haze, which will not come off with cleaning.

Overfiring of a stove is a condition where excessive temperatures are reached, beyond the design capabilities of the appliance. The damage that occurs from overfiring is not covered under the manufacturer's limited warranty.

Also see *Troubleshooting* on **Page 29**.

SELECTING THE PROPER VENTING SYSTEM

The appliance is merely one component of a larger system. The other equally important component is the venting system. This is necessary for achieving the required flow of combustion air to the fire chamber and for safely removing unwanted combustion by-products from the appliance. If the venting system's design does not promote these ends, the system may not function properly. Poorly functioning venting systems may create performance problems as well as be a safety hazard. **A draft test should read greater than .04' W.C. (inches water column) and less than .08" W.C.** As per NFPA-211 standard (see paragraph below), the installer must take into account all variables within the installation and install the appliance in such a manner that satisfies the draft requirements of the appliance. See *Chimney Guidelines* below to assist you in selecting the proper venting system for your installation.

American National Standards Institute ANSI/NFPA 211, Standard for Chimneys, Fireplaces, Vents, and Solid Fuel-Burning Appliances - See Draft Section:

A chimney or vent shall be so designed and constructed to develop a flow sufficient to completely remove all flue and vent gases to the outside atmosphere. The venting system shall satisfy the draft requirements of the connected appliance in accordance with the manufacturer's instructions.

Chimney Guidelines:

- This appliance requires approximately 12 feet minimum of "effective draw" provided by the venting system. As a rule of thumb, every 90 degree total direction change in the venting will result in a loss of approximately 5 feet of "effective draw." Example: If two 45 degree offsets are used, subtract 5 feet from the actual vertical vent height to determine your "effective draw." In this case if you had 14 feet of vertical vent, the effective draw would only be approximately 9 feet (14 ft. - 5 ft. = 9 ft.), therefore it may be necessary to add additional height to the venting system.
- Do not install an offset within the first two feet above the flue outlet on the appliance.
- In well insulated and weather tight homes, it may be difficult to establish a good draft up your chimney. The poor draft is caused by a shortage of air in the house. In this situation an Outside Air Kit may need to be installed (See *Negative Pressure Warning* on **Page 5** and *Outside Combustion Air* on **Page 17**).

CHIMNEY HEIGHT REQUIREMENTS

The chimney must extend 3' (.92m) above the level of roof penetration and a minimum of 2' (.61m) higher than any roof surface within 10' (3m) (see below). Check with your local building officials for additional requirements for your area.

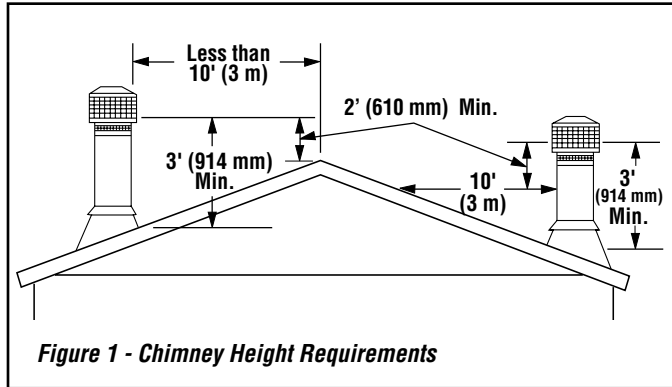

To pass inspection in nearly any jurisdiction, the chimney must meet both safety and exhaust flow requirements. The (3' by 2') by 10' rule applies to both masonry and factory-built chimneys.

*** Ref. USA - National Standard, NFPA 211-latest edition and Canada National Standard CSA B365-01-latest edition. Vents installed with a listed cap shall terminate in accordance with the terms of the cap's listings.**

NEGATIVE PRESSURE WARNING

This appliance is not designed to be operated in a negative pressure. In very airtight homes with large kitchen exhaust fans, furnace cold air returns, fresh air exchange systems and any other air system in close proximity to the heating appliance may create a negative pressure in the same room as the heating appliance. This can create dangerous back drafting of the stove and chimney joints, drawing combustion by-products into the home. Be sure your home has adequate makeup air to eliminate negative pressures caused by the above-mentioned sources. Outside air connected to the appliance probably will not resolve such a problem as the appliance is not the source of negative pressure. IHP accepts no liability for damages resulting from negative pressures described here.

Ventilation Requirements - Provide adequate air for combustion. The fresh air requirements of this appliance must be met within the space where it will be installed. Ventilation is essential when using a Solid-Fuel-Burning heater. In well insulated and weather tight homes, it may be difficult to establish a good draft up the chimney (caused by a shortage of air in the home). The lack of air is caused by many common household appliances which exhaust air from the home (such as a furnace, heat pump, air conditioner, clothes dryer, exhaust fans, fireplaces, and other fuel burning appliances). Also, the combustion process of this heater uses oxygen from inside the dwelling. If the available fresh air delivery in the dwelling is insufficient to support the demands of these appliances, problems can result (e.g. excessive negative pressure can develop in the dwelling which will affect the rate at which this appliance can draft thus resulting in performance problems). To correct this problem it may help to open a window (preferably on the windward side of the house) or install an optional outside air kit.

CLEARANCES TO COMBUSTIBLES

WARNING: BE ABSOLUTELY SURE THE DISTANCE BETWEEN THE HEATER AND THE SURFACE OF ANY COMBUSTIBLE CONSTRUCTION IS NOT LESS THAN SHOWN IN THE FIGURES ON PAGE 7 FOR MODEL GV230 WOODSTOVE AND ON PAGE 8 FOR MODEL GV300 WOODSTOVE.

Floor Protection

USA - The floor in front and under the heater must be protected with noncombustible material. The covering must extend 16" in front of the door opening of the heater and 8" to either side of the door opening.

Canada - The floor in front and under the heater must be protected with noncombustible material. The covering must extend 450 mm in front of the door opening of the heater and 200 mm to either side of the stove body and 200 mm to the rear or to the wall, whichever is smaller.

USA and Canada - A chimney connector / venting extends horizontally over the floor, protection must also cover the floor under the connector / venting and at least 2" (51 mm) to either side.

Alcove Installations USA and Canada - The floor protection must be a thermally rated non-combustible floor protector. See **Page 9** for GV230 stoves or **Page 10** for GV300 stoves for details on determining acceptable floor protection materials or hearth pads for alcove installations.

Alcove Installation

Clearances - In alcove installations, only 6" double wall connector pipe can be used (single wall or single wall pipe with shield is not allowed).

Minimum alcove width between combustible materials:

GV230 - 52" (1321 mm)

GV300 - 54" (1372 mm)

Maximum alcove depth:

GV230 and GV300 - 48" (1219 mm)

Minimum alcove height:

GV230 and GV300 - 72" (1829 mm)

Thermal Floor Protection

GV230 - Thermal floor protection is only required where the stove is installed into an alcove.

GV300 - Thermal floor protection is required in all installations.

Chimney and Connector

Minimum 6" diameter, minimum 24 MSG black steel connector pipe with UL103HT listed factory-built chimney suitable for use with solid fuels or masonry chimney. Horizontal connection not tested, refer to local building codes for installation. See installation instructions for details. Restrictions apply! Read instructions before installing.

Residential chimney systems must be from the same brands as listed for mobile homes but connector pipe may be double wall, single wall, or single wall with shield as listed.

This appliance may be vented into a code-approved masonry chimney with flue liner.

WARNING: CHIMNEY CONNECTOR MUST BE IN GOOD CONDITION AND KEPT CLEAN. DO NOT INSTALL DAMAGED PARTS.

All of the stove connector pipe used must be of the same brand. The chimney that the stove pipe transitions into may be a different brand. Other than the transition of the stove pipe into the chimney, do Not mix different brand vent components. Install all vent components per vent manufacturer's instructions.

The chimney connector shall not pass through an attic or roof space, closet or similar concealed space, or a floor, or ceiling. Where passage through a wall, or partition of combustible construction is desired, the installation shall conform to CAN/CSA-B365, Installation Code for Solid-Fuel-Burning Appliances and Equipment.

There must be an effective vapor barrier at the location where the chimney or other component penetrates to the exterior of the structure. Follow the vent manufacturer's detailed instructions.

IMPORTANT NOTE: See *Draft Requirements* and *Selecting a Proper Venting System* on **Page 4** to assist you in choosing the proper venting system for your installation.

Clearance dimensions are to flue collar. If a single wall connector pipe with shield is used, a 1 inch air space is needed between pipe and shield. Shield attaches to rear of stove pipe and must run from stove top to ceiling. Pipe shield shall be UL listed.

Components Required For Installations

Legs OR Pedestal Assembly.

Use all required components specified for this appliance. Do not substitute.

WARNING: In the event that you remove the blower for any reason, make sure a cover plate (available from IHP) is installed before using the heater. Note: The cover plate is not necessary if a blower has never been installed because a knock-out will be in place to act as the cover.

Grandview™ GV230

INSTALLATION CLEARANCES - REFER TO FIGURES 2, 3 AND 4

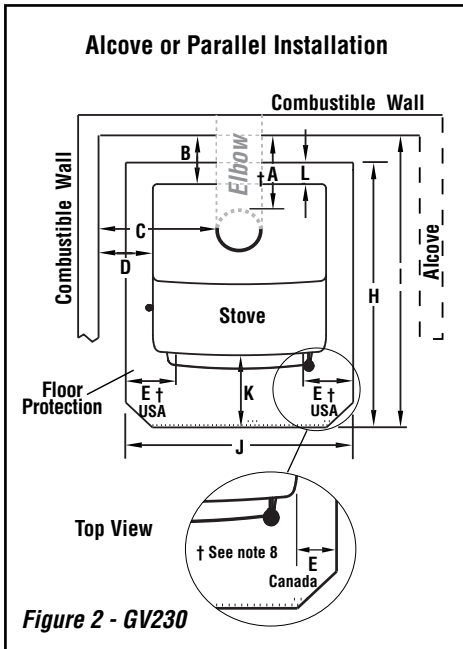

Figure 2 - GV230

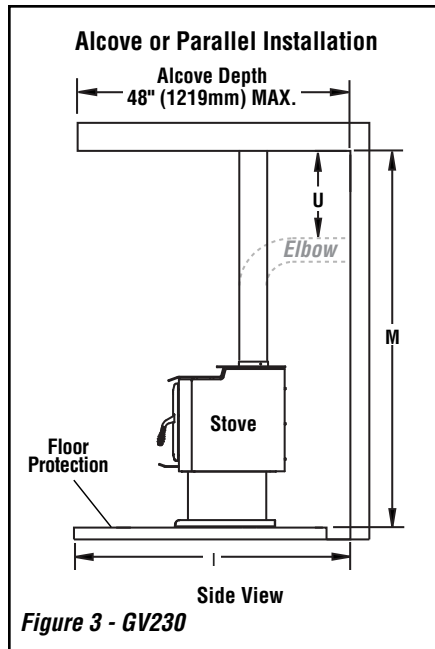

Figure 3 - GV230

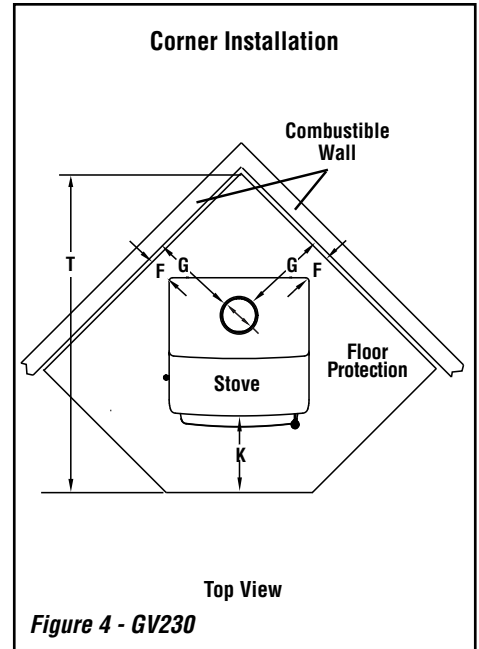

Figure 4 - GV230

USA - inches (millimeters)



PIPE	INSTALLATION	A (3)	B (1)	C (3)	D (1)	E (8)	F (1,4)	G(3,4)	H (2)	I (6)	J (2)	K (7)	L (5)	M	T (6)	U
Single Wall	Residential-Vertical Vent	16 (406)	12-3/8 (314)	22 (559)	12-1/2 (318)	8 (200)	5-11/16 (145)	16 (406)	38-5/8 (981)	51 (1295)	33 (838)	16 (406)	0 (0)	84 (2134)	58-7/8 (1495)	N/A N/A
Single Wall	Residential-With Elbow	19 (483)	15-3/8 (391)	23 (584)	13-1/2 (343)	8 (200)	5-11/16 (145)	16 (406)	38-5/8 (981)	54 (1372)	33 (838)	16 (406)	0 (0)	84 (2134)	58-7/8 (1495)	19 N/A
Double Wall	Residential or Mobile Home-Vertical Vent	10 (254)	6-3/8 (162)	20 (508)	10-1/2 (267)	8 (200)	4-11/16 (119)	15 (381)	38-5/8 (981)	45 (1143)	33 (838)	16 (406)	0 (0)	84 (2134)	57-1/2 (1461)	N/A N/A
Double Wall	Residential or Mobile Home-With Elbow	10 (254)	6-3/8 (162)	21 (533)	11-1/2 (292)	8 (200)	4-11/16 (119)	15 (381)	38-5/8 (981)	45 (1143)	33 (838)	16 (406)	0 (0)	84 (2134)	57-1/2 (1461)	10 N/A
Double Wall	Alcove-Vertical Vent	13 (330)	9-3/8 (238)	22-1/2 (572)	13 (330)	8 (200)	N/A N/A	N/A N/A	38-5/8 (981)	48 (1219)	33 (838)	16 (406)	0 (0)	72 (1829)	N/A N/A	N/A N/A

CANADA - inches (millimeters)



PIPE	INSTALLATION	A (3)	B (1)	C (3)	D (1)	E (8)	F (1,4)	G(3,4)	H (2)	I (6)	J (2)	K (7)	L (5)	M	T (6)	U
Single Wall	Residential-Vertical Vent	16 (406)	12-3/8 (314)	22 (559)	12-1/2 (318)	8 (200)	5-11/16 (145)	16 (406)	49 (1235)	53 (1346)	41-1/8 (1045)	18 (450)	8 (200)	84 (2134)	58-7/8 (1495)	N/A N/A
Single Wall	Residential-With Elbow	19 (483)	15-3/8 (391)	23 (584)	13-1/2 (343)	8 (200)	5-11/16 (145)	16 (406)	49 (1235)	56 (1422)	41-1/8 (1045)	18 (450)	8 (200)	84 (2134)	58-7/8 (1495)	19 (483)
Double Wall	Residential or Mobile Home-Vertical Vent	10 (254)	6-5/16 (160)	20 (508)	10-1/2 (267)	8 (200)	4-11/16 (119)	15 (381)	47 (1193)	47 (1193)	41-1/8 (1045)	18 (450)	8 (200)	84 (2134)	57-1/2 (1461)	N/A N/A
Double Wall	Residential or Mobile Home-With Elbow	10 (254)	6-5/16 (160)	21 (533)	11-9/16 (293)	8 (200)	4-11/16 (119)	15 (381)	47 (1193)	47 (1193)	41-1/8 (1045)	18 (450)	8 (200)	84 (2134)	57-1/2 (1461)	10 (254)
Double Wall	Alcove-Vertical Vent	13 (330)	9-3/8 (238)	22-1/2 (572)	13-1/16 (331)	8 (200)	N/A N/A	N/A N/A	49 (1235)	50 (1270)	41-1/8 (1045)	18 (450)	8 (200)	72 (1829)	N/A N/A	N/A N/A

Footnotes:

- These dimensions to the stove body are for reference only. Actual distances should be measured from the stove's flue collar.
- Minimum noncombustible hearth pad dimensions.
- Clearances to connector pipe shall be measured from the flue collar of the stove.
- Not applicable to alcove installations.
- In corner applications, when installed at minimum back wall clearances, the required floor protection is dimensioned off the back plane of the stove, therefore the floor protection required off the back corners (at a 45 degree angle) only needs to extend to the wall. This situation will only occur in CANADA installations.
- Reference dimension only, to assist in planning the installation.
- Measured from front of floor protection to the front of firebox.
- USA=8" (200mm) from door opening, Canada=8" (200mm) from sides and back of unit.

Safety and General

Planning Installation

Installation

Operation

Maintenance

Troubleshooting

Parts / Accessories

Grandview™ GV300

INSTALLATION CLEARANCES - REFER TO FIGURES 5, 6 AND 7

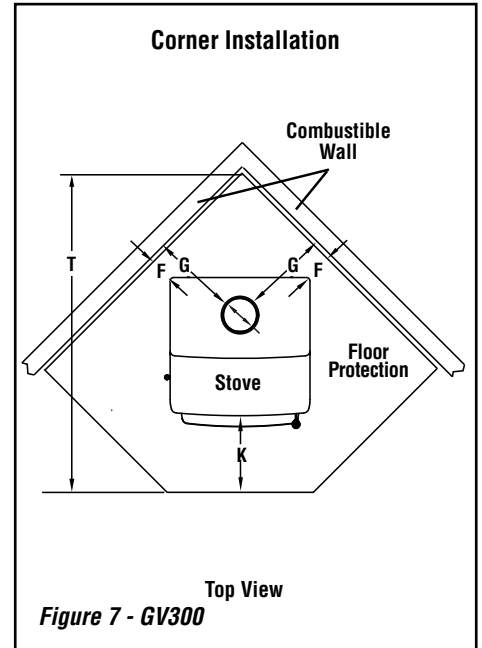
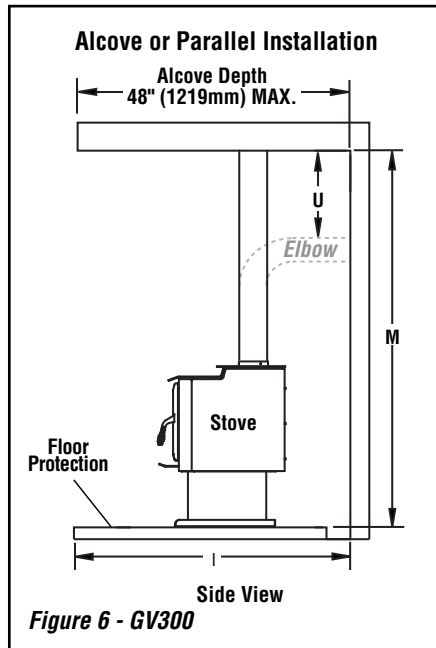
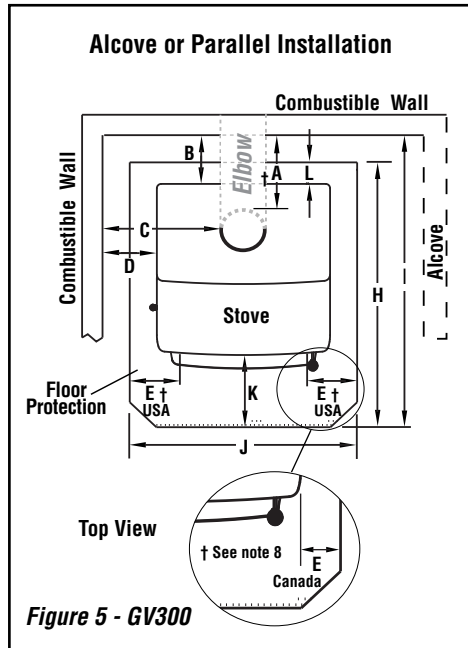

USA - inches (millimeters)

PIPE	INSTALLATION	A (3)	B (1)	C (3)	D (1)	E (8)	F (1,4)	G(3,4)	H (2)	I (6)	J (2)	K (7)	L (5)	M	T (6)	U
Single Wall	Residential-Vertical Vent	16	12-3/8	25-1/8	15	8	6	17	41-1/8	53-1/2	33	16	0	84	62-7/8	N/A
		(406)	(314)	(635)	(381)	(200)	(152)	(432)	(1045)	(1359)	(838)	(406)	(0)	(2134)	(1597)	N/A
Single Wall	Residential-With Elbow	19-5/8	16	26-1/8	16	8	6	17	41-1/8	57-1/8	33	16	0	84	62-7/8	19
		(499)	(406)	(664)	(406)	(200)	(152)	(432)	(1045)	(1451)	(838)	(406)	(0)	(2134)	(1597)	N/A
Double Wall	Residential or Mobile Home-Vertical Vent	11-5/8	8	23-1/8	13	8	5	16	41-1/8	49-1/8	33	16	0	84	61-7/16	N/A
		(295)	(203)	(587)	(330)	(200)	(127)	(406)	(1045)	(1248)	(838)	(406)	(0)	(2134)	(1561)	N/A
Double Wall	Residential or Mobile Home-With Elbow	11-5/8	8	24-1/8	14	8	5	16	41-1/8	49-1/8	33	16	0	84	61-7/16	10
		(295)	(203)	(613)	(356)	(200)	(127)	(406)	(1045)	(1248)	(838)	(406)	(0)	(2134)	(1561)	N/A
Double Wall	Alcove-Vertical Vent	13-5/8	10	26-1/8	16	8	N/A	N/A	41-1/8	51-1/8	33	16	0	72	N/A	N/A
		(346)	(254)	(664)	(406)	(200)	N/A	N/A	(1045)	(1299)	(838)	(406)	(0)	(1829)	N/A	N/A

CANADA - inches (millimeters)

PIPE	INSTALLATION	A (3)	B (1)	C (3)	D (1)	E (8)	F (1,4)	G(3,4)	H (2)	I (6)	J (2)	K (7)	L (5)	M	T (6)	U
Single Wall	Residential-Vertical Vent	16	12-3/8	25-1/8	15	8	6	17	51-1/8	55-1/2	41-1/8	18	8	84	64-7/8	N/A
		(406)	(314)	(635)	(381)	(200)	(152)	(432)	(1299)	(1410)	(1045)	(450)	(200)	(2134)	(1648)	N/A
Single Wall	Residential-With Elbow	19-5/8	16	26-1/8	16	8	6	17	51-1/8	59-1/8	41-1/8	18	8	84	64-7/8	19
		(499)	(406)	(664)	(406)	(200)	(152)	(432)	(1299)	(1502)	(1045)	(450)	(200)	(2134)	(1648)	(483)
Double Wall	Residential or Mobile Home-Vertical Vent	11-5/8	8	23-1/8	13	8	5	16	51-1/8	51-1/8	41-1/8	18	8	84	63-7/16	N/A
		(295)	(203)	(587)	(330)	(200)	(127)	(406)	(1299)	(1299)	(1045)	(450)	(200)	(2134)	(1611)	N/A
Double Wall	Residential or Mobile Home-With Elbow	11-5/8	8	24-1/8	14	8	5	16	51-1/8	51-1/8	41-1/8	18	8	84	63-7/16	10
		(295)	(203)	(613)	(356)	(200)	(127)	(406)	(1299)	(1299)	(1045)	(450)	(200)	(2134)	(1611)	(254)
Double Wall	Alcove-Vertical Vent	13-5/8	10	26-1/8	16	8	N/A	N/A	51-1/8	53-1/8	41-1/8	18	8	72	N/A	N/A
		(346)	(254)	(664)	(406)	(200)	N/A	N/A	(1299)	(1349)	(1045)	(450)	(200)	(1829)	N/A	N/A

Footnotes:

- These dimensions to the stove body are for reference only. Actual distances should be measured from the stove's flue collar.
- Minimum noncombustible hearth pad dimensions.
- Clearances to connector pipe shall be measured from the flue collar of the stove.
- Not applicable to alcove installations.
- In corner applications, when installed at minimum back wall clearances, the required floor protection is dimensioned off the back plane of the stove, therefore the floor protection required off the back corners (at a 45 degree angle) only needs to extend to the wall. This situation will only occur in CANADA installations.
- Reference dimension only, to assist in planning the installation.
- Measured from front of floor protection to the front of firebox.
- USA=8" (200mm) from door opening, Canada=8" (200mm) from sides and back of unit.

NOTE: DIAGRAMS & ILLUSTRATIONS ARE NOT TO SCALE.

Grandview™ GV230

ALCOVE INSTALLATIONS - FLOOR PROTECTION

When the Grandview™ 230 is installed in an Alcove, the floor protection must be a thermally rated non-combustible floor protector meeting or exceeding a thermal rating of $k = .47$ or equivalent with a listed thickness of 1/2" (12.7 mm) minimum in the USA and Canada. The thermal protection must extend 16" in front of the heater and 8" to each side (measured from the door opening).

Using Alternate Material As Floor Protection

The floor protection or alternate material used as a floor protector must be constructed of a durable noncombustible material having an equal or better thermal conductivity value (lower k value) of $k = .47$ BTU/IN FT² HR °F or a thermal resistance that equals or exceeds $r = 2.13$ HR °F FT² IN/BTU with a minimum thickness of 1/2". With these values, determine the minimum thickness of the alternate material required using the formula(s) and shown in **Table 1**.

Note: Any noncombustible material having a minimum thickness of 1/2" (12.7mm) whose k value is less than .47 or whose r value is more than 2.13 is acceptable. If the alternate material used has a higher k value or lower r value will require a greater thickness of the material used. In some cases, if the k value is less or the r value higher, a thinner material may be used.

Methods of determining floor protection equivalents:

To determine the thickness required for the alternate material when either the "k" value or "r" value is known, use either the **k formula** or **r formula**.

Example: If Micore 160 Mineral Fiber Board is to be used for the floor protection, how thick must this material be?

k_M = k value per inch of **alternate** material

r_M = r value per inch of **alternate** material

T_M = minimum thickness required for **alternate** material

T_S = standard thickness of the **alternate** material

k_L = k value per inch of **listed** material

r_L = r value per inch of **listed** material

T_L = minimum thickness of **listed** material

Note: An asterisk "*" indicates, it is a value taken from **Table 1**.

Using the k formula:

k formula:

Minimum thickness of alternate material (T_M) = $\frac{k\text{-value (per Inch) of alternate material } (k_M) \times k\text{-value (per inch) of listed material } (k_L)}{.47}$ x Specified min. thickness of listed material (T_L)

$$T_M \text{ (inches)} = \frac{k_M}{*.47} \times T_L$$

$$T_M \text{ (inches)} = \frac{*.35}{*.47} \times .50"$$

$$.312 \text{ (inches)} = .745 \times .50"$$

Answer - The minimum required thickness of the Micore 160 is .372" therefore round up to nearest standard thickness available which is 3/8" (.375")

Using the r formula:

Minimum thickness of alternate material = $\frac{r\text{-value (per Inch) of listed material } (r_L)}{r\text{-value (per inch) of alternate material } (r_M)}$ x Specified min. thickness of listed material

$$T_M \text{ (inches)} = \frac{r_L}{r_M} \times T_L$$

$$T_M \text{ (inches)} = \frac{*2.13}{*2.86} \times .50"$$

$$.312 \text{ (inches)} = .745 \times .50"$$

Answer - The minimum required thickness of the Micore 160 is .372" therefore round up to nearest standard thickness available which is 3/8" (.375")

Listed Material			
	k (per inch)	r (per inch)	Listed Min. Thickness
Listed Material	.47 k_L	2.13 r_L	1/2" (.50") T_L
** Approved Alternate Materials for Floor/Hearth Protection			
Alternative Materials	Thermal Values		Minimum Thickness (rounded to nearest 1/8 inch)
	k (per inch) k_M	r (per inch) r_M	Min. Thickness T_M
Kaowool M Board	.47	2.13	.5" (1/2")
Micore 160™ U.S. Gypsum	.35	2.86	.37" (3/8")
Micore 300™ U.S. Gypsum	.46	2.17	.49" (1/2")
Durock™ Cement Board U.S. Gypsum	1.92	.52	2.04" (2-1/8")
Hardibacker™	1.95	.51	2.07" (2-1/8")
Hardibacker 500™	2.30	.43	2.45" (2-1/2")
Cultured Stone Hearth-stone™	2.82	.35	3" (3")
Wonderboard	3.23	.31	3.44" (3-1/2")
Super Firetemp M Johns-Manville	.61	1.64	.65" (3/4")
Super Firetemp L Johns-Manville	.54	1.85	.57" (5/8")
Face brick	9.00	.111	9.57" (9-5/8")
Common brick	5.00	.20	5.32" (5-3/8")
Cement mortar	5.00	.20	5.32" (5-3/8")
Ceramic tile	12.5	.08	13.30" (13-3/8")
Marble	~11	~.09	11.70" (11-3/4")

Table 1 - USA AND CANADA REQUIREMENTS - GV230

** If the hearth extension material(s) that is intended to be used is NOT listed on Table 1, the material can still be used if the material(s) is non-combustible. However, the manufacturer of the material must provide either the listed k-value per inch or r-value per inch with listed thickness so that the minimum thickness required for the hearth can be calculated (per instructions here or as specified in the NFI Certification Manuals).

Note: Also see NFI (National Fireplace Institute) Certification Manuals showing other acceptable calculation methods and acceptable alternate materials which can be used.

Grandview™ GV300

FLOOR PROTECTION

The Grandview™ 300 floor protection must be a thermally rated non-combustible floor protector meeting or exceeding a thermal rating of k=.47 or equivalent with a listed thickness of 1-1/2" (38.1mm) minimum in the USA and Canada. The thermal protection must extend 16" in front of the heater (measuring from the front of the firebox) and the the width of the heater (26-1/2").

Using Alternate Material As Floor Protection

The floor protection or alternate material used as a floor protector must be constructed of a durable noncombustible material having an equal or better thermal conductivity value (lower k value) of k =.47 BTU/IN FT2 HR °F or a thermal resistance that equals or exceeds r = 2.13 HR °F FT2 IN/BTU with a minimum thickness of 1-1/2". With these values, determine the minimum thickness of the alternate material required using the formula(s) and shown in **Table 2**.

Note: Any noncombustible material having a minimum thickness of 1-1/2" (38.1 mm) whose k value is less than .47 or whose r value is more than 2.13 is acceptable. If the alternate material used has a higher k value or lower r value will require a greater thickness of the material used. In some cases, if the k value is less or the r value higher, a thinner material may be used.

Methods of determining floor protection equivalents:

To determine the thickness required for the alternate material when either the "k" value or "r" value is known, use either the **k formula** or **r formula**.

Example: If Micore 160 Mineral Fiber Board is to be used for the floor protection, how thick must this material be?

k_M = k value per inch of **alternate** material
 r_M = r value per inch of **alternate** material
 T_M = minimum thickness required for **alternate** material
 T_S = **standard thickness of the alternate material**

k_L = k value per inch of **listed** material
 r_L = r value per inch of **listed** material
 T_L = minimum thickness of **listed** material

Note: An asterisk "*" indicates, it is a value taken from **Table 2**.
Using the k formula:

k formula:

$$\begin{aligned} \text{Minimum thickness of alternate material (T}_M\text{)} &= \frac{\text{k-value (per Inch) of alternate material (k}_M\text{)} \times \text{k-value (per inch) of listed material (k}_L\text{)}}{\text{Specified min. thickness of listed material (T}_L\text{)}} \\ T_M \text{ (inches)} &= \frac{k_M}{.47} \times T_L \\ T_M \text{ (inches)} &= \frac{.35}{.47} \times 1.50" \\ 1.117 \text{ (inches)} &= .745 \times 1.50" \end{aligned}$$

Answer - The minimum required thickness of the Micore 160 is 1.117" therefore round up to nearest total standard thickness - Example: Use two 5/8" (.625") boards for a total thickness of 1-1/4" (1.250").

Using the r formula:

$$\begin{aligned} \text{Minimum thickness of alternate material} &= \frac{\text{r-value (per Inch) of listed material} \times \text{r-value (per inch) of alternate material}}{\text{Specified min. thickness of listed material}} \\ T_M \text{ (inches)} &= \frac{r_L}{r_M} \times T_L \\ T_M \text{ (inches)} &= \frac{2.13}{2.86} \times 1.50" \\ 1.117 \text{ (inches)} &= .745 \times 1.50" \end{aligned}$$

Answer - The minimum required thickness of the Micore 160 is 1.117" therefore round up to nearest total standard thickness - Example: Use two 5/8" (.625") boards for a total thickness of 1-1/4" (1.250").

Listed Material			
	k (per inch)	r (per inch)	Listed Min. Thickness
Listed Material	.47 k_L	2.13 r_L	1-1/2" (1.5") T_L
** Approved Alternate Materials for Floor/Hearth Protection			
Alternative Materials	Thermal Values		Minimum Thickness (rounded to nearest 1/8 inch)
	k (per inch) k_M	r (per inch) r_M	Min. Thickness T_M
Kaowool M Board	.47	2.13	1.5" (1-1/2")
Micore 160™ U.S. Gypsum	.35	2.86	1.12" (1-1/8")
Micore 300™ U.S. Gypsum	.46	2.17	1.47" (1-1/2")
Durock™ Cement Board U.S. Gypsum	1.92	.52	6.13" (6-1/8")
Hardibacker™	1.95	.51	6.22" (6-1/4")
Hardibacker 500™	2.30	.43	7.34" (7-3/8")
Cultured Stone Hearth-stone™	2.82	.35	9" (9")
Wonderboard	3.23	.31	10.3" (10-3/8")
Super Firetemp M Johns-Manville	.61	1.64	1.95" (2")
Super Firetemp L Johns-Manville	.54	1.85	1.72" (1-3/4")
Face brick	9.00	.111	28.72" (28-3/4")
Common brick	5.00	.20	15.96" (16")
Cement mortar	5.00	.20	15.96" (16")
Ceramic tile	12.5	.08	39.89" (39-7/8")
Marble	~11	~.09	35.12" (35-1/8")

Table 2 - USA AND CANADA REQUIREMENTS - GV300

** If the hearth extension material(s) that is intended to be used is NOT listed on Table 2, the material can still be used if the material(s) is non-combustible. However, the manufacturer of the material must provide either the listed k-value per inch or r-value per inch with listed thickness so that the minimum thickness required for the hearth can be calculated (per instructions here or as specified in the NFI Certification Manuals).

NOTE: Also see NFI (National Fireplace Institute) Certification Manuals showing other acceptable calculation methods and acceptable alternate materials which can be used.

SPECIFICATIONS - GV230 AND GV300

GV230 Specifications

Stove Pipe Diameter	
Single Wall or	
Double Wall	6" (152 mm)
Log Length	
	16" W x 18" D Max. (406mm W x 457mm D Max.)
Firebox	
	17" W x 19" D x 12-1/2" H Max. (432mm W x 483mm D x 318mm H Max.) Volume = 2.3 cu. ft.
Glass Viewing Area	
	16-1/2" W x 11-5/16" H (419mm W x 287mm H)
EPA Test Load:	
Cord Wood: ①	28,200 BTUs/hr. 76,000 BTUs/hr.
Maximum Burn Times ①	
	12 hours
Heating Capacity ①	
	1200 to 2200 sq. ft.
EPA Grams Per Hour	
	3.6 gr/hr
EPA Phase II and Washington State Approved	

GV300 Specifications

Stove Pipe Diameter	
Single Wall or	
Double Wall	6" (152 mm)
Log Length	
	17" W x 21" D Max. (431.8mm W x 533mm D Max.)
Firebox	
	18.2" W x 21.23" D x 13" H Max. (462.28mm W x 539.25mm D x 330.2mm H Max.) Volume=2.91 cu. ft.
Glass Viewing Area	
	16-1/2" W x 11-5/16" H (419mm W x 287mm H)
EPA Test Load:	
Cord Wood: ①	29,181 BTUs/hr. 100,000 BTUs/hr.
Maximum Burn Times ①	
	14 hours
Heating Capacity ①	
	2000 to 3000 sq. ft.
EPA Grams Per Hour	
	3.09 gr/hr
EPA Phase II and Washington State Approved	

Product Reference Information			
Cat. No.	Description	Ship. Wt.	Ship. Volume
H8338	Grandview 230	385 lb.	20.09 cu. ft.
H8958	Grandview 300	445 lb.	20.09 cu. ft.

NOTES

- Dimensions shown are approximations only (+/- 1/4")
- Diagrams, illustrations and photographs are not to scale - consult installation instructions. Product designs, materials, dimensions, specifications, colors and prices are subject to change or discontinuance without notice.
- Approved for residential, manufactured home (GV230 only), and alcove installations.
- Optional Kits Available:
Door Trim Kit
Blower
Outside Air Kit
Louvers
Legs (choice of three styles)
Pedestal
Ash Drawer for legs or for pedestal

① Square-foot heating capacities and burn times are approximations only. Actual performance may vary depending upon home design and insulation, ceiling heights, climate, condition and type of wood used, appliance location, burn rate, accessories chosen, chimney installation and how the appliance is operated.

The Grandview™ Models GV230 and GV300 woodstoves are safety listed with the following agency:

- PFS Corporation, Tested to UL 1482, ULC S627



GV230 - Report # 14-182
GV300 - Report # 14-194

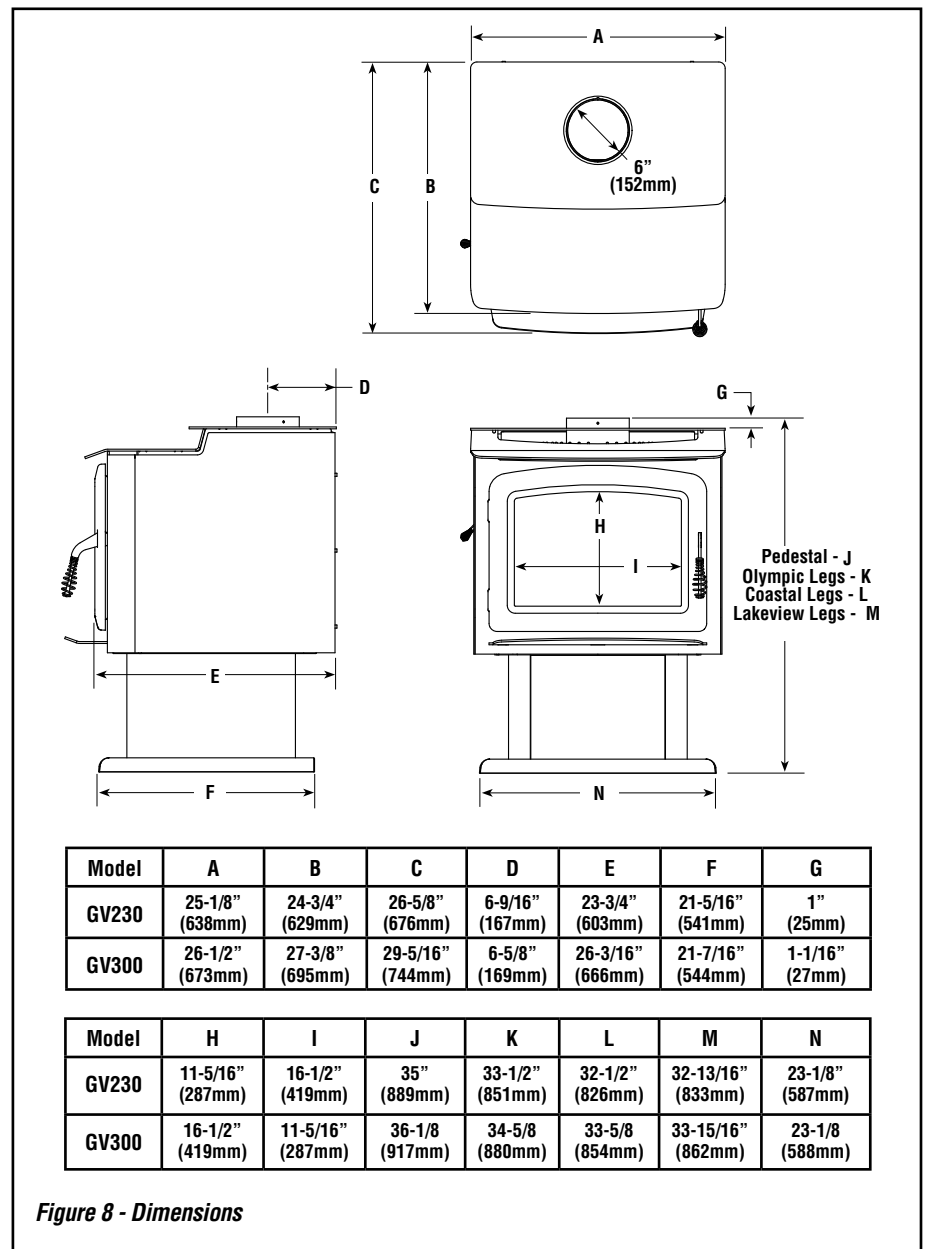

Figure 8 - Dimensions

NOTE: DIAGRAMS & ILLUSTRATIONS ARE NOT TO SCALE.

Single Wall Pipe

Using 6" Diameter Single Wall Connector Pipe

INSTALL VENTING SYSTEM PER VENT MANUFACTURERS INSTRUCTIONS!

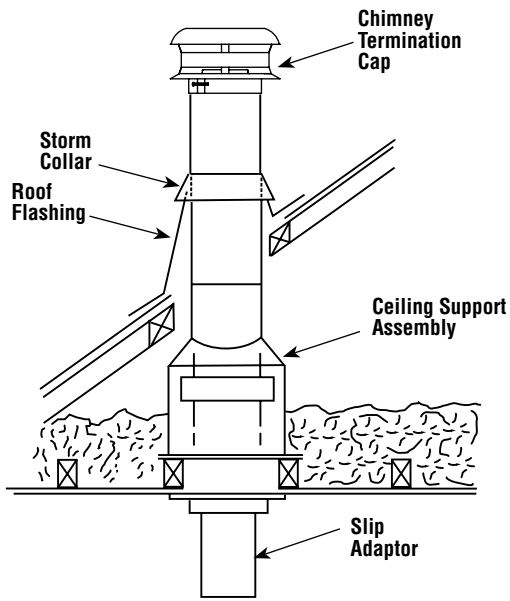

Single wall stove pipe must not pass through attics, closets, walls or ceilings. It is used to connect this appliance to a factory built or masonry chimney.

Fasten each stove pipe connection with at least 3 sheet metal screws.

6" x 24" 24-gage black steel or 26 gage blued steel single wall pipe

Fasten stove pipe to flue collar with 3 sheet metal screws.

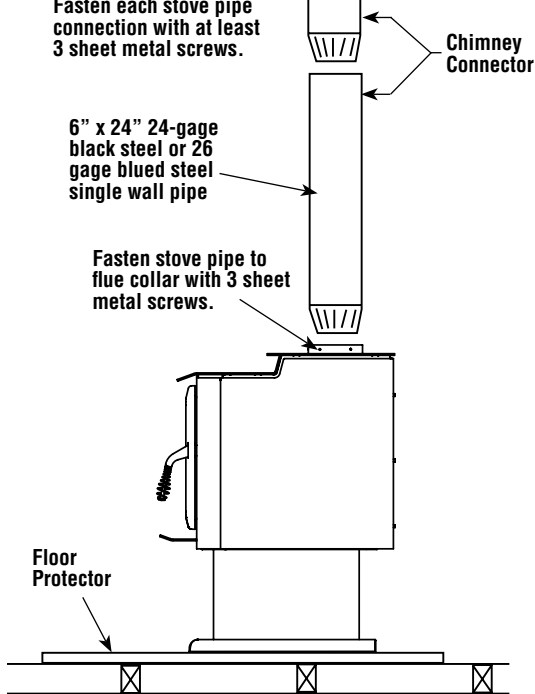

Figure 9 - Typical Installation

STAINLESS STEEL LINER

Using 6" Diameter Rigid Stainless Steel Liner

INSTALL VENTING SYSTEM PER VENT MANUFACTURERS INSTRUCTIONS!

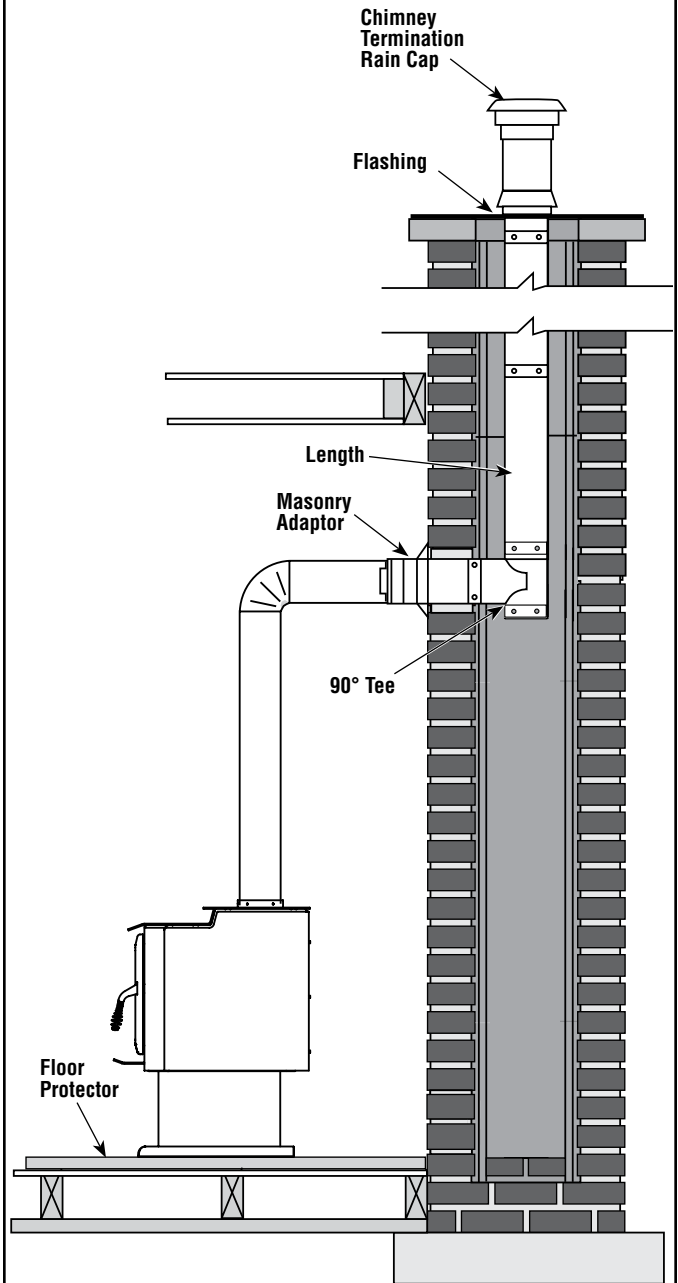

Figure 10 - Connected to a Masonry Chimney

YOUR CHIMNEY INSTALLATION MUST COMPLY WITH LOCAL BUILDING AND FIRE CODES.

CHIMNEY INSTALLATION

- Install chimney as per manufacturer's instructions. Some brands of pipe may require removal of the spacer ring in the flue collar.
- All horizontal runs of pipe should be as short as possible and are required by NFPA No. 211 to have an upward pitch or rise in the same direction the smoke travels of no less than 1/4" to the linear foot. The connector pipe must meet minimum clearances in any direction to walls or other combustible materials. It must attach to a listed double wall metal chimney at least 6" in diameter or to a masonry chimney with a flue passage of at least 48 square inches.
- It is required that a chimney connector pipe not extend further than the inner wall of the flue when it is connected to a masonry chimney and that it either be cemented to the masonry or be installed without cement in a thimble connected to the masonry wall. When the connector is inserted into a thimble, the joint must be tight enough so that it will not be dislodged in normal use. Install connector at no less than the minimum clearances from the ceiling when using a 90-degree elbow to pass through combustible constructions.
- Chimney connector pipes should never pass through a floor, ceiling, fire wall, partition, or combustible construction of any type unless certain precautions are taken. The best method is to use a listed thimble and a listed chimney in accordance with the manufacturer's directions. NFPA No. 211 gives approved methods for passing a flue pipe through combustible constructions (see Page 14).

Manufactured Home Installations (GV230 ONLY)
(ref. Figure 11)

Model GV230 woodstove is approved for installation into a manufactured (mobile) home. NOTE: Model GV300 woodstove is not approved for installation into a manufactured (mobile) home.

Installation should be in accordance with the Mobile Home Construction and Safety Standard, Title 24 CFR, Part 3280 (in Canada CAN/CSA Z240 MH), or, when such a standard is not applicable, the Standard for Mobile Home Installations, ANSI A225.1.

All mobile home installations require an outside air kit (see Page 32 for ordering information). The stove must be secured to the floor and grounded to the chassis of the mobile home.

WARNING: DO NOT INSTALL IN SLEEPING ROOM OF A MOBILE HOME.

CAUTION: THE STRUCTURAL INTEGRITY OF THE MOBILE HOME FLOOR, WALL AND CEILING/ROOF MUST BE MAINTAINED.

Approved Chimney* - Your stove is approved for use with Class A, UL 103 HT (U.S.) / ULC-S629 (Canada) Listed Residential Type and Building Heating Appliance Chimney (HT chimney - 2100° Fahrenheit) and double wall connector pipe. Approved chimney brands are Security Chimneys™, Jakes Evans/GSW, Dura-Vent, Metal Fab, Ameri-Tec, Metalbestos and Industrial Chimney (ICC).

Clearances to connector shall be measured from 6" flue collar. Restrictions apply! Read instructions before installing.

YOUR CHIMNEY INSTALLATION MUST COMPLY WITH LOCAL BUILDING AND FIRE CODES.

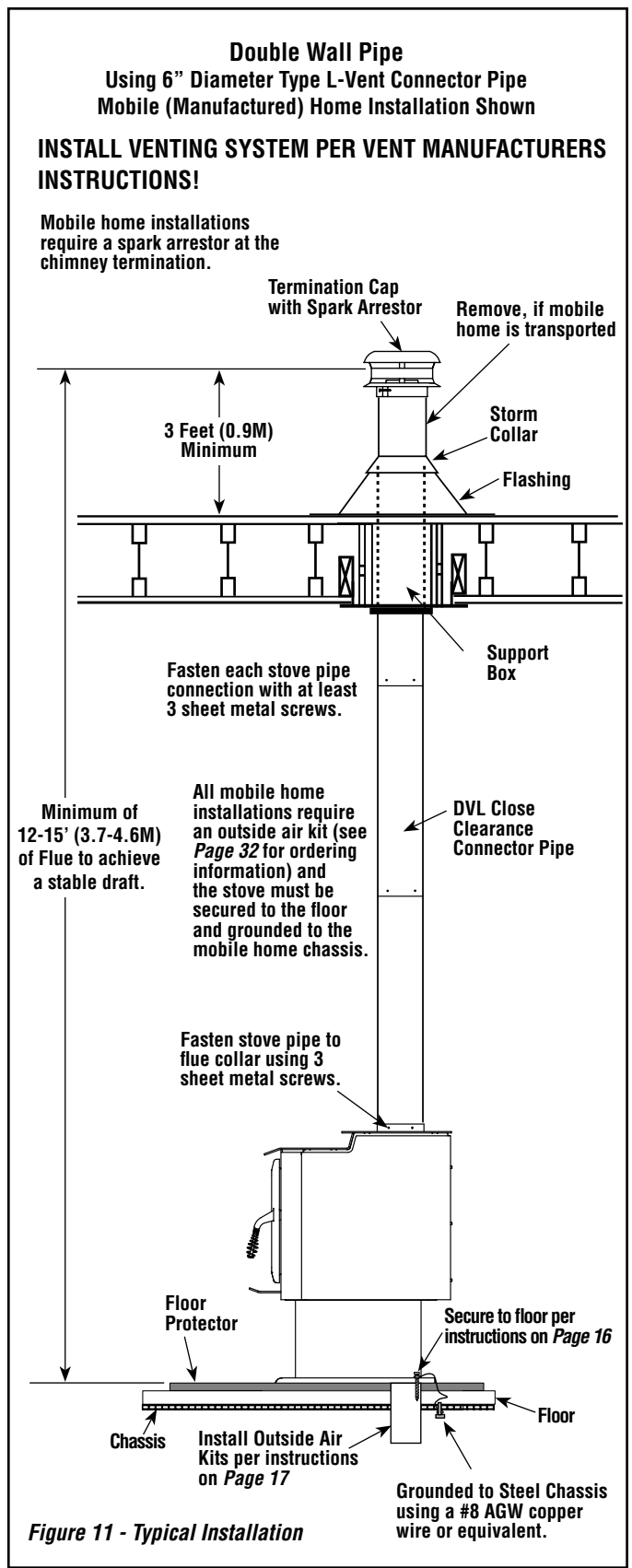

Figure 11 - Typical Installation

Chimney Connector Systems and Clearances from Combustible Walls for Residential Heating Appliances (NFPA 211) Refer to Figure 12.

System A. Minimum 3.5 in. (90 mm) thick brick masonry wall framed into combustible wall with a minimum of 12 in. (305 mm) brick separation from clay liner to combustibles. Fireclay liner (ASTM C 315, Standard Specification for Clay Flue Linings, or equivalent), minimum 5/8 in. (16 mm) wall thickness, shall run from outer surface of brick wall to, but not beyond, the inner surface of chimney flue liner and shall be firmly cemented in place.

Clearance: 12 in. (305 mm)

System B. Solid-insulated, listed factory-built chimney length of the same inside diameter as the chimney connector and having 1 in. (25.4 mm) or more of insulation with a minimum 9 in. (229 mm) air space between the outer wall of the chimney length and combustibles.

The inner end of the chimney length shall be flush with the inside of the masonry chimney flue and shall be sealed to the flue and to the brick masonry penetration with non-water-soluble refractory cement. Supports shall be securely fastened to wall surfaces on all sides.

Fasteners between supports and the chimney length shall not penetrate the chimney liner.

Clearance: 9 in. (229 mm)

System C. Sheet steel chimney connector, minimum 24 gauge [0.024 in. (0.61 mm)] in thickness, with a ventilated thimble, minimum 24 gauge [0.024 in. (0.61 mm)] in thickness, having two 1 in. (25.4 mm) air channels, separated from combustibles by a minimum of 6 in. (152 mm) of glass fiber insulation. Opening shall be covered, and thimble supported with a sheet steel support, minimum 24 gauge [0.024 in. (0.61 mm)] in thickness.

Supports shall be securely fastened to wall surfaces on all sides and shall be sized to fit and hold chimney section. Fasteners used to secure chimney section shall not penetrate chimney flue liner.

Clearance: 6 in. (152 mm)

System D. Solid-insulated, listed factory-built chimney length with an inside diameter 2 in. (51 mm) larger than the chimney connector and having 1 in. (25.4 mm) or more of insulation, serving as a pass-through for a single wall sheet steel chimney connector of minimum 24 gauge [0.024 in. (0.61 mm)] thickness, with a minimum 2 in. (51 mm) air space between the outer wall of chimney section and combustibles. Minimum length of chimney section shall be 12 in. (305 mm). Chimney section concentric with and spaced 1 in. (25.4 mm) away from connector by means of sheet steel support plates on both ends of chimney section. Opening shall be covered, and chimney section supported on both sides with sheet steel supports of minimum 24 gauge [0.024 in. (0.61 mm)] thickness.

Supports shall be securely fastened to wall surfaces on all sides and shall be sized to fit and hold chimney section. Fasteners used to secure chimney section shall not penetrate chimney flue liner.

Clearance: 2 in. (51 mm)

Additional requirements:

1. Insulation material used as part of wall pass-through system shall be of noncombustible material and shall have a thermal conductivity of 1.0 Btu-in./hr-ft² - °F (4.88 kg-cal/hr-m² - °C) or less.
2. All clearances and thicknesses are minimums; larger clearances and thicknesses shall be permitted.
3. Any material used to close up an opening for the connector shall be of noncombustible material.
4. A connector to a masonry chimney, except for System B, shall extend in one continuous piece through the wall pass-through system and the chimney wall to the inner face of the flue liner, but not beyond.

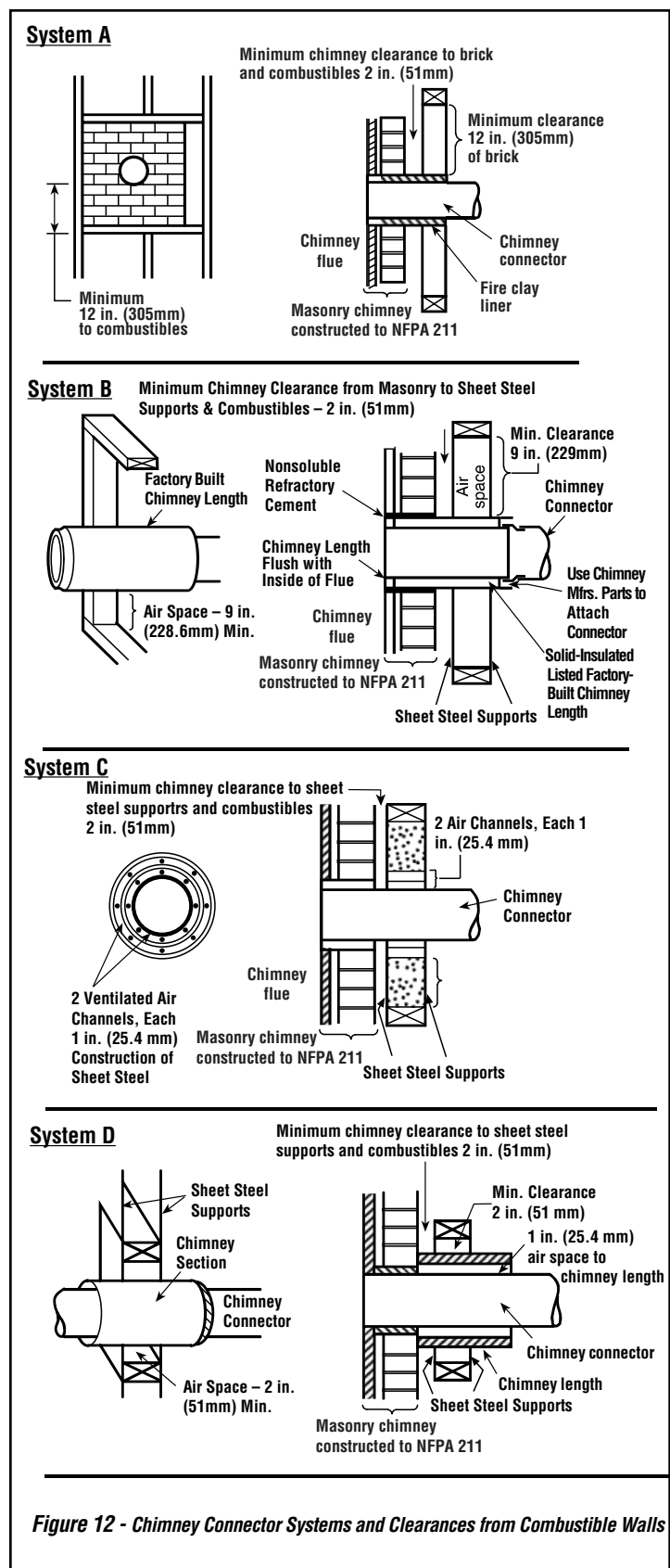

Figure 12 - Chimney Connector Systems and Clearances from Combustible Walls

LEG INSTALLATION

Residential and Mobile Homes

(Tying down and grounding are required only in mobile homes)

Open all cartons, if any and remove the contents upon receipt and check for any damaged or missing parts. If there is hidden damage, notify your freight company or IHP dealer immediately.

CAUTION: Wear gloves during installation in case of sharp edges on the stove.

Leg Installation

1. Carefully place stove on it's back. Be careful not to scratch the stove, use a piece of cardboard or carpet to protect the back of the stove.
2. Using a 9/16" wrench or socket remove the bolt in each of the four corners along with the attached shipping brackets.
3. Remove legs from the packaging and using the bolts and washers that come with the legs install each leg in each corner with one bolt and one washer.
4. Before the legs are fully tightened down make sure that they are aligned correctly to match the front and side planes of the stove.
5. The stove can now be set up on the legs making sure that all baffle boards and bricks are set back in place. These items may have shifted when the stove was placed on it's back.
6. If it is necessary to level, secure, or ground your stove, use the holes in the bottom of the leg for those applications. To level the stove use leg leveling kit (P/N H8407) or leveling pads (P/N H7638). Level by adjusting the bolt or leveling pad down on each leg that is not in full contact with the hearth or surface below that the stove is located on.

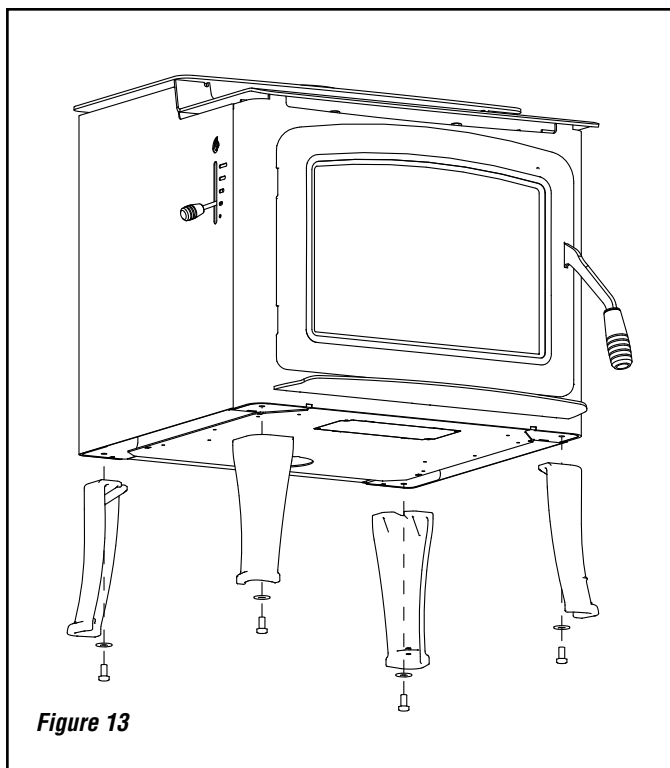

Figure 13

PEDESTAL INSTALLATION

Residential and Mobile Homes

(Tying down and grounding are required only in mobile homes)

Open all cartons, if any and remove the contents upon receipt and check for any damaged or missing parts. If there is hidden damage, notify your freight company or IHP dealer immediately.

CAUTION: Wear gloves during installation in case of sharp edges on the stove.

Pedestal Installation

1. Remove the heater from the carton, if packaged, upon receipt and check for any damaged or missing parts.
2. Install the 10-24 screws included with the pedestal kit to the bottom of the stove as seen in **Figure 14**. You will need a 5/32" allen wrench to complete this.
3. Carefully place stove on it's back. Be careful not to scratch the stove, use a piece of cardboard or carpet to protect the back of the stove.
4. The pedestal will have key hole slots that line up with the screws that were placed in the bottom of the stove. Carefully install pedestal on the installed screws with the open end of the pedestal towards the rear of the stove.
5. Assuring that the pedestal is placed correctly in slots then tighten all six screws.
6. The stove can now be set up on the pedestal making sure that all baffle boards and bricks are set back in place. These items may have shifted when the stove was placed on it's back.
7. When installing a pedestal on this stove you **MUST** plug the one leg mounting bolt hole, located on the bottom of the stove in the front left corner, with the bolt that was used to mount the shipping legs. **FAILURE TO INSTALL THIS BOLT PROPERLY WILL RESULT IN REDUCED CONTROL OF THE STOVE'S COMBUSTION SYSTEM!**

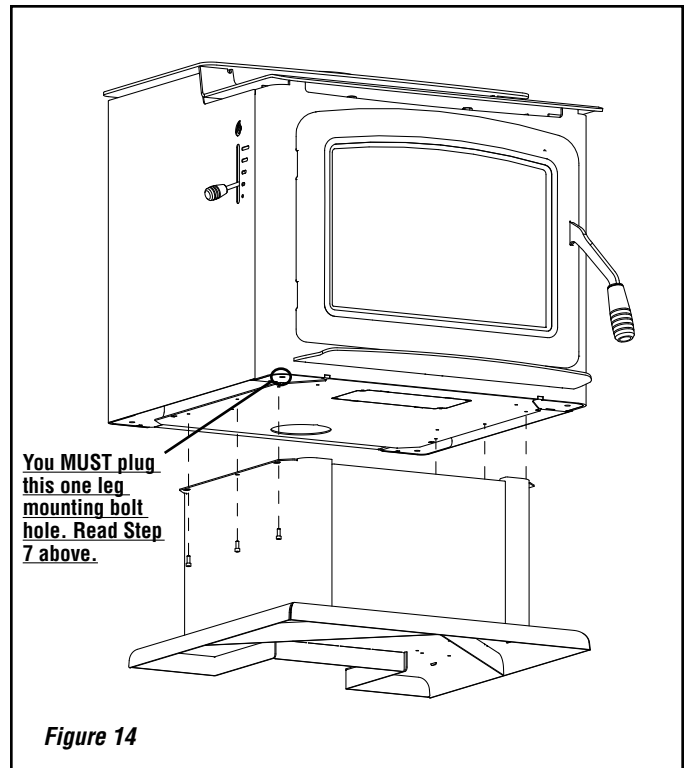

Figure 14

**ATTACHING STOVE TO MANUFACTURED HOME FLOOR -
GV230 WOODSTOVE ONLY**

Leg Tie Down Kits (Manufactured [mobile] Homes)

Order:

H7665 Leg Tie Down Kit, Coastal and Lakeview Legs

H5308 Leg Tie Down Kit, Olympic Legs

ATTACHING STOVE TO MANUFACTURED HOME FLOOR

THE STOVE MUST BE ATTACHED TO THE FLOOR AT NO LESS THAN TWO POINTS

Pedestal

Locate the two holes on the back of the pedestal (**Figure 15**). Secure the pedestal to the floor using two field provided 1/4" screws.

Lakeview and Coastal Legs

Connect the bolt down bracket to each leg using kit (P/N H7665) screw as shown in **Figure 16**. Secure the leg bracket to the floor using one field provided 1/4" bolt.

Olympic Legs

Connect the bolt down bracket to each leg using kit (P/N H5308) screw as shown in **Figure 17**. Secure the leg bracket to the floor using one field provided 1/4" screw.

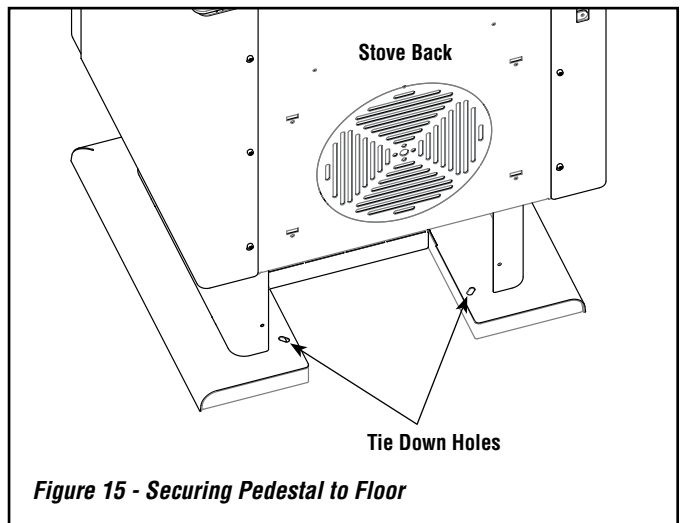

Figure 15 - Securing Pedestal to Floor

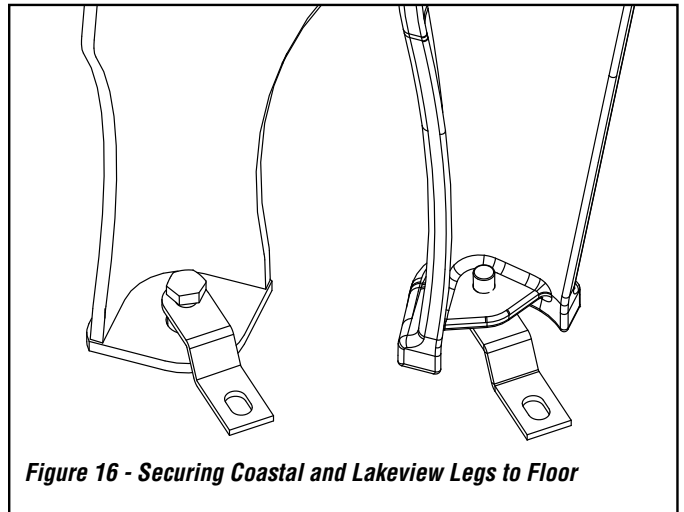

Figure 16 - Securing Coastal and Lakeview Legs to Floor

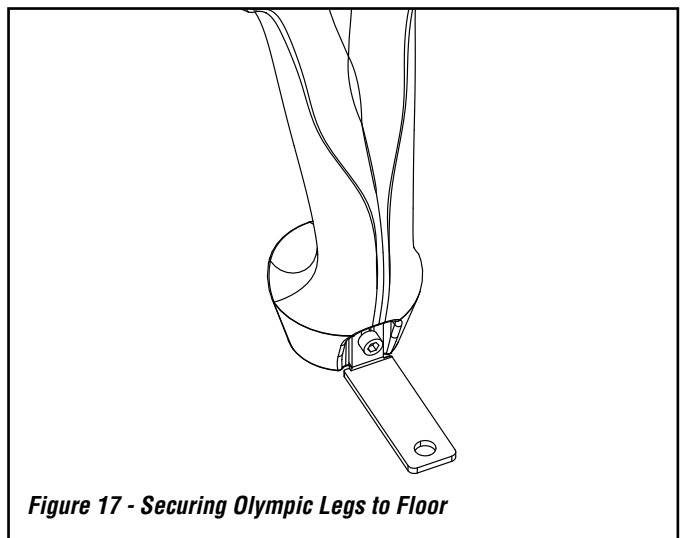

Figure 17 - Securing Olympic Legs to Floor

OUTSIDE COMBUSTION AIR KIT INSTALLATION - GV230 AND GV300

Outside Air Kits

Order:

1 ea. P/N UZIAD Outside Air Coupler Kit (connects outside air ducting, UZI, to stove)

AND

1 ea. P/N UZI Outside Air Ducting Kit (includes 4" insulated flex x 10' long)

An outside air kit is required in Manufactured (mobile) Home installations. For residential installations, check with local authorities having jurisdiction in your area, it may be mandatory.

Outside Air Kit Coupler

To install the outside air kit coupler onto the stove, line up the "V" notch in the coupler with the "V" notch in the open on the bottom of the stove. Push and twist so the rolled edge catches the bottom of the stove and continue turning full 360° to lock the coupler in place.

Through the Wall Outside Air Kit Installation (refer to Figures 18, 19 and 20)

The outside air assembly may be installed according to the following requirements:

- Duct length should be kept to a minimum.
- The air intake register must not be installed more than ten (10) feet (3050 mm) above the base of the stove.
- The fresh air must come from outside the house. The air intake must not draw air from the attic, from the basement or garage.
- The air intake should be installed where it is not likely to be blocked by snow or exposed to extreme wind and away from automobile exhaust fumes, gas meters and other vents.
- The duct and register may be installed above or below floor level.

- Make a 4-1/4" (110 mm) hole in the outside wall of the house at the chosen location. From outside, place the outside air register in the hole (open side down) and fasten the register to the wall, with screws as shown (see **Figure 20**).
- Install the coupler onto the existing collar on stove (see **Figure 18**).
- Attach the duct to the coupler on stove (see **Figure 19**). Using the aluminium tape provided, wrap the tape around the joint between the flexible duct and the air inlet.

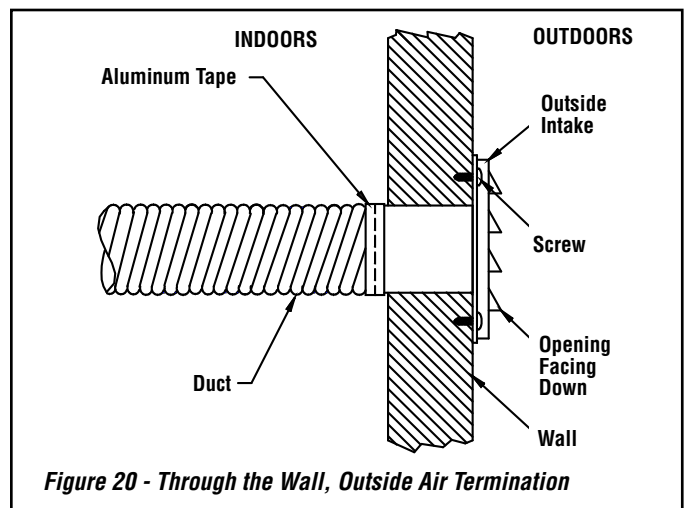
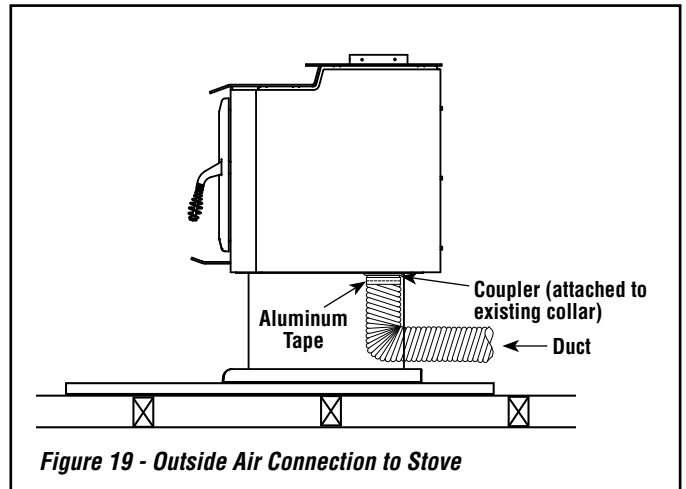
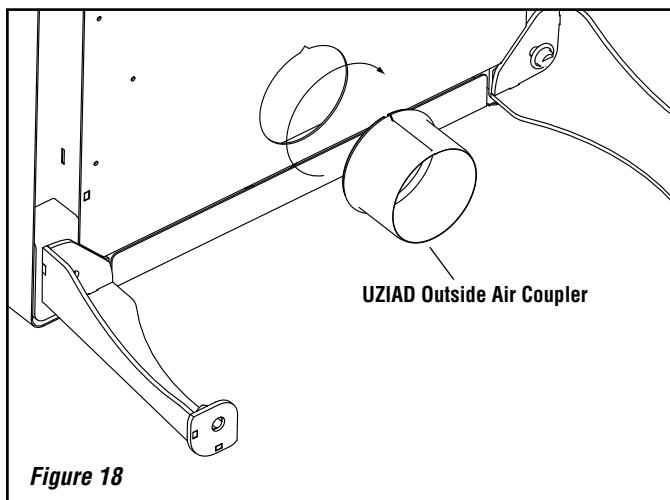

Manufactured Home Through the Floor Outside Air Kit Installation (refer to Figure 21) - Model GV230 woodstoves only.

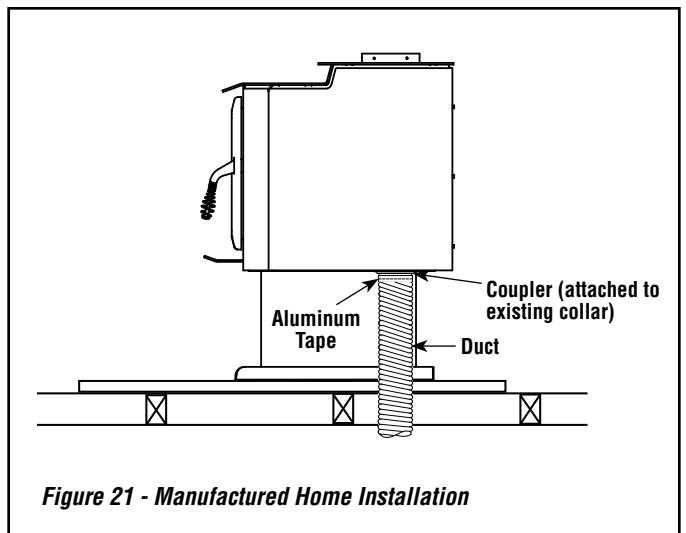

Grandview™ GV230

BRICK AND BAFFLE INSTALLATION

CAUTION: Wear gloves during brick installation in case of sharp edges inside the stove.

WARNING: IF THE BRICKS ARE NOT INSTALLED EXACTLY AS SHOWN BELOW, THEY COULD FALL OUT OF PLACE DURING REFUELING OR BURNING OF THE STOVE CAUSING SERIOUS INJURY.

1. Install firebox bottom brick spacers on both the left and right side of firebox. The brick spacers are located in the package with the manual. Assure that brick spacers are pushed to each side until they are in full contact with the firebox side on each side.
NOTE: Your brick spacers may already be welded in place.
2. Install brick #1-20 in the numbered sequence shown in **Figure 22**.
3. Brick's 13 and 14 will be located between the steel firebox and rear baffle board (already installed).
4. Once all bricks are installed confirm that the already installed baffle boards are in their correct location and resting on the secondary burn tubes.

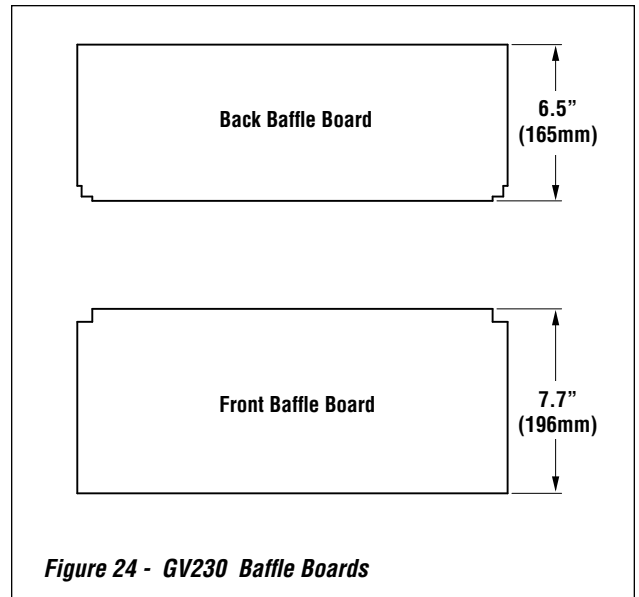
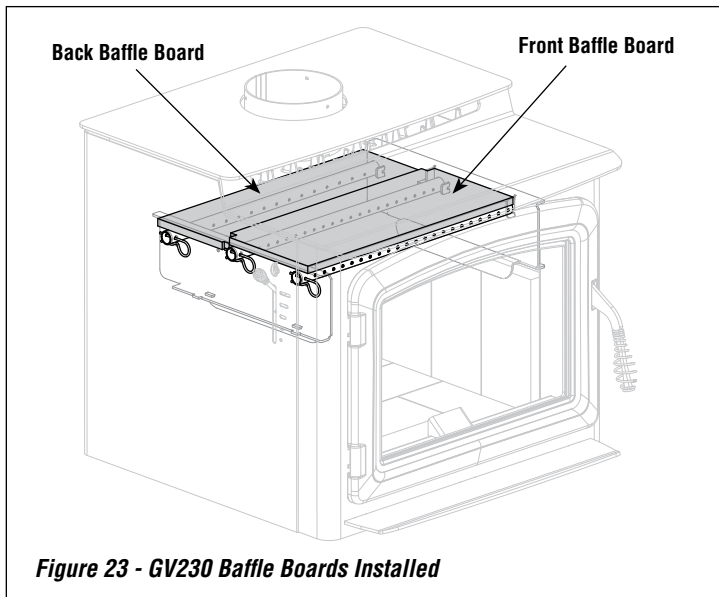
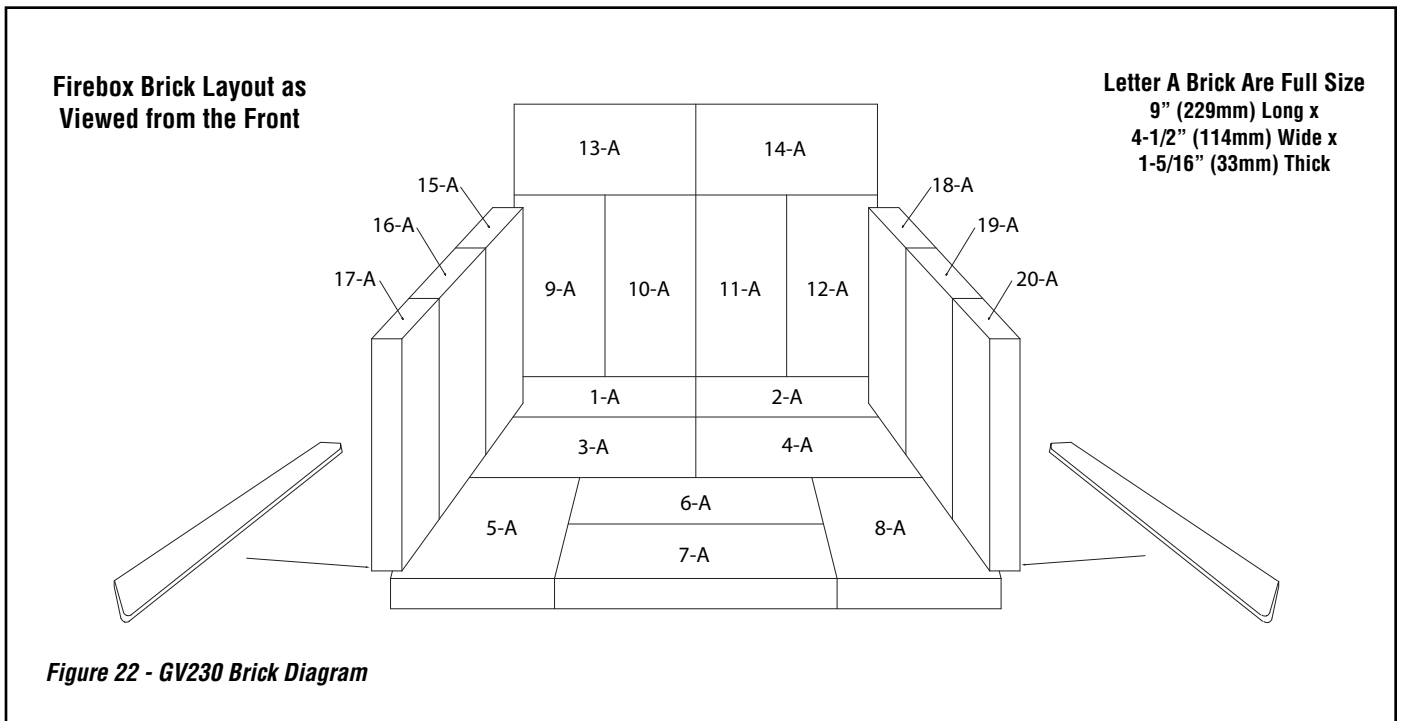

Grandview™ GV300

BRICK AND BAFFLE INSTALLATION

CAUTION: Wear gloves during brick installation in case of sharp edges inside the stove.

WARNING: IF THE BRICKS ARE NOT INSTALLED EXACTLY AS SHOWN BELOW, THEY COULD FALL OUT OF PLACE DURING REFUELING OR BURNING OF THE STOVE CAUSING SERIOUS INJURY.

1. Install brick #1-6 in the numbered sequence shown in *Figure 25*.
2. Install rear brick support which is included in the firebox on top of #5 and #6 brick. This support will be locked into place when the remainder of side brick are installed.
3. Install remaining brick #7-26 in the numbered sequence shown in *Figure 25*.
4. Once all the bricks are installed confirm that the already installed baffle boards are in their correct location and resting on the secondary burn tubes.

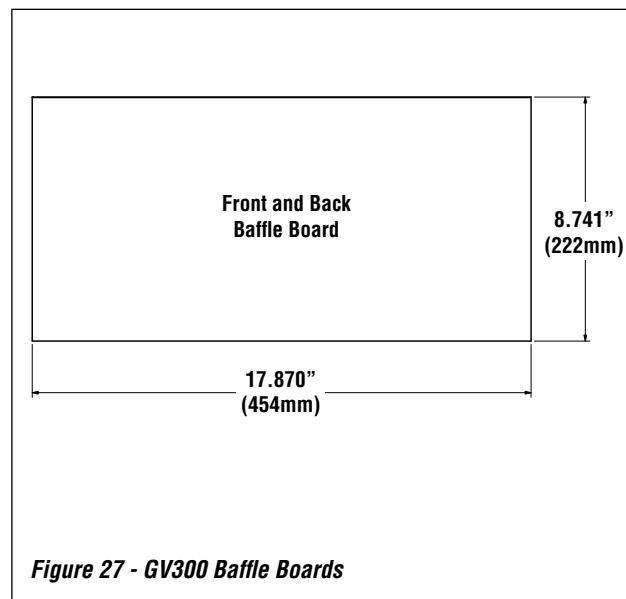
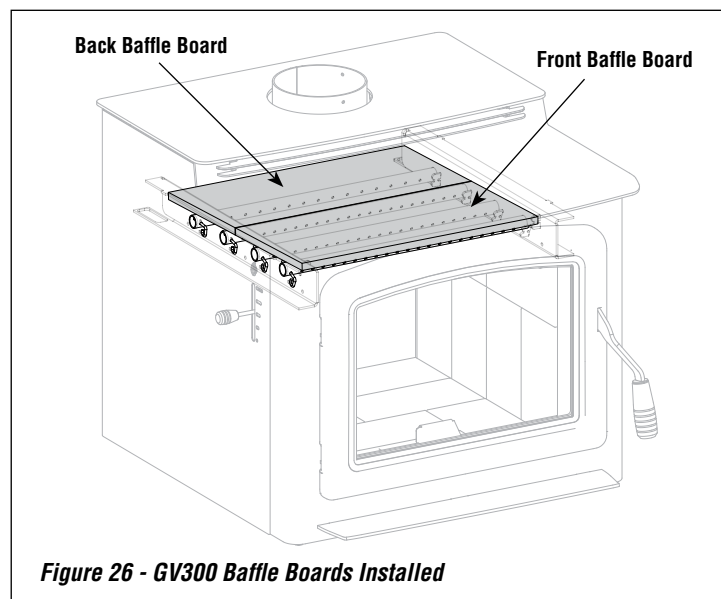
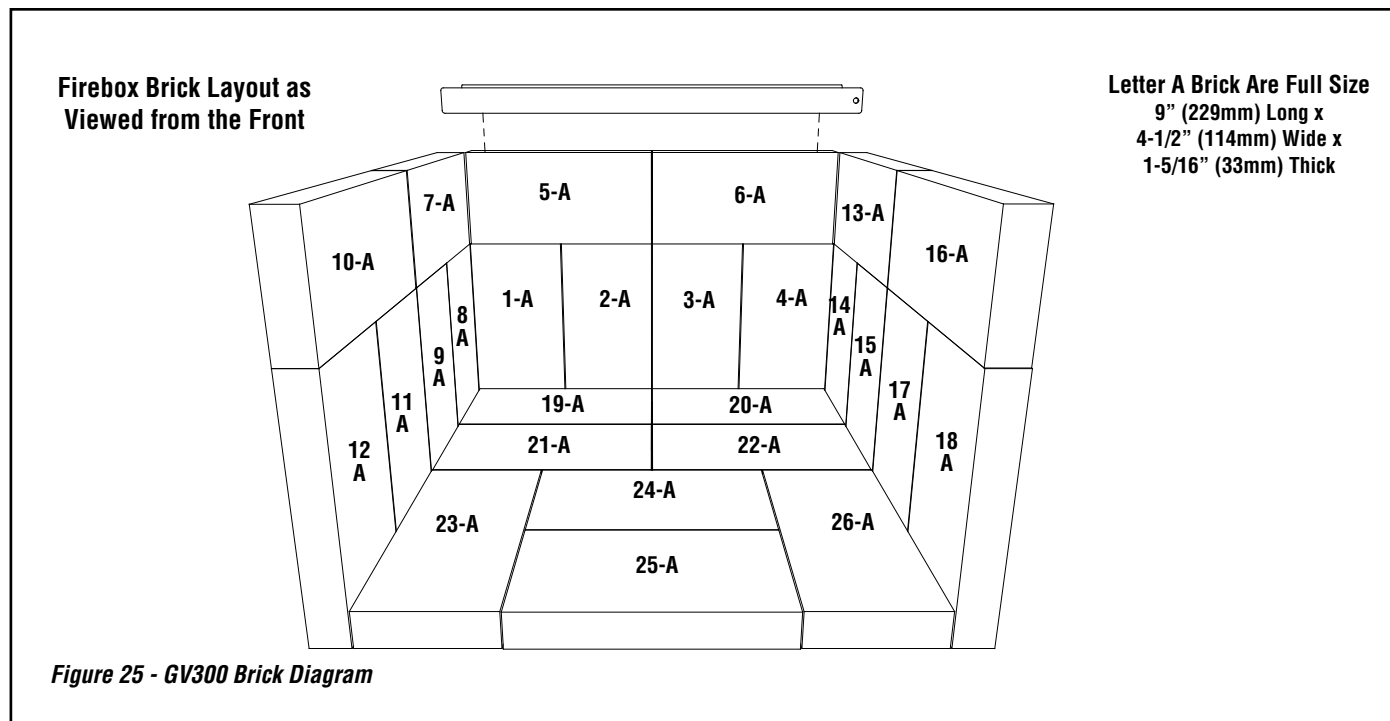

FOR MOBILE HOME INSTALLS

- Be sure the stove is properly grounded
- Be sure the stove is properly securely fastened to the floor
- Be sure the outside air vent is free of obstructions and has a mesh screen in place

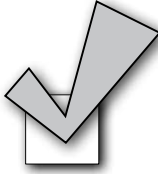

POST INSTALLATION CHECKS

- Check that all chimney pipe joints are secured and installed according to the manufacturers instruction.
- If used, make sure the outside air kit is properly installed and unobstructed.
- Make sure the legs or pedestal are securely fastened to the stove.
- Double check all stove clearances.
- Be sure bricks and baffle boards are properly installed.
- If plated accessories are used, be sure surfaces are clean prior to firing the stove.
See Page 21

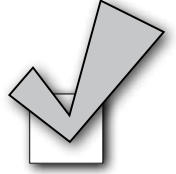

FOR YOUR OWN PROTECTION AND INSURANCE PURPOSES, HAVE YOUR CHIMNEY AND CONNECTOR PIPE INSTALLATION INSPECTED BY YOUR LOCAL BUILDING CODE AUTHORITY OR FIRE MARSHAL BEFORE STARTING A FIRE IN YOUR STOVE. NOTIFY YOUR INSURANCE COMPANY.

PAINT CURING

If your stove has plated accessories, be sure to clean it with a household type glass cleaner and a very soft cloth to remove any fingerprints and residues prior to the first fire and before any fire if the plated surfaces have been handled or soiled. Do not close the door tightly during the "Burn-In Period." Also, open the door frequently (every 5-10 minutes) to keep the gasket from adhering to the curing paint. Ventilate the house well during these first firings as the paint gives off carbon dioxide and unpleasant odors. It is recommended that persons sensitive to an imbalance in the indoor air quality avoid the appliance during the curing process.

Your new stove is painted with a high temperature paint that cures during the first few firings. We recommend that you put your stove or fireplace insert through a regimen of three burns. The first two should last for 20 minutes each at 250 degrees (the appliance should be allowed to cool completely between each burn). The third should be a burn of at least 450 degrees F. for 45-60 minutes. The paint will become soft, gummy and emit non-toxic smoke during these burns. During these first burns, open the appliance door frequently to help prevent the door gasket from adhering to the appliance. After the appliance cools down for the third time, the paint will harden. **DO NOT BUILD A LARGE ROARING FIRE UNTIL THIS CURING EFFECT IS COMPLETE OR YOU MAY DAMAGE THE FINISH OF YOUR STOVE.** Spray can touch-ups should be done only with a high temperature stove paint (cat. no. H8159), available from all IHP dealers.

BURN-IN PERIOD

Please be patient with the heat output of your appliance for the first few weeks. The steel will go through a curing process that eliminates moisture, which is deep in the steel and firebrick. This moisture will reduce initial heat output of your appliance and may make it difficult to start. **(DO NOT OVERFIRE THE STOVE DURING THIS PROCESS. IF THE STOVE OR CHIMNEY BECOMES RED, REDUCE THE AMOUNT OF AIR ENTERING THE STOVE IMMEDIATELY).**

OPERATING HINTS

1. Burn only dry, well-seasoned cord wood. In some states it is illegal to burn wet wood or anything other than clean, dry wood products.
2. Your stove or fireplace insert is designed to operate with the door closed! Operate only with the door shut tightly at all times except when loading wood and possibly on start up to establish a draft. Never leave the unit unattended while the front door is opened.
3. **DO NOT** contact or move the baffle boards while loading wood. Occasionally check the baffle to assure that the boards are in their correct location.

4. **CAUTION: THE DRAFT CONTROL MUST BE FULLY OPEN BEFORE OPENING THE DOOR TO AVOID POSSIBLE COMBUSTION FLASH!!** (Ignition of hot volatile gases as the door is opened).
5. Feeding excessive amounts of fuel to the appliance should be avoided. It is important to supply it with sufficient draft and fuel to maintain a moderately hot fire. If, during overnight burns, heavy creosote deposits develop inside your stove and on the door, the draft is set too low - review your burning habits!

DOOR OPERATION

Do not operate the appliance with the door open or ajar other than possibly during start up to create a draft (Do not leave the unit unattended while the front door is slightly open during start up). Operating the appliance with the door open other than in initial start up if needed will produce extreme temperatures within the appliance. Damage caused from over-firing is not covered under the manufacturers limited warranty.

! WARNING

Be careful not to abuse door assembly by striking or slamming it. If the door assembly or glass is broken or damaged, they must be replaced with factory original parts before heater can be safely operated. Use only components provided by the manufacturer as replacement parts.

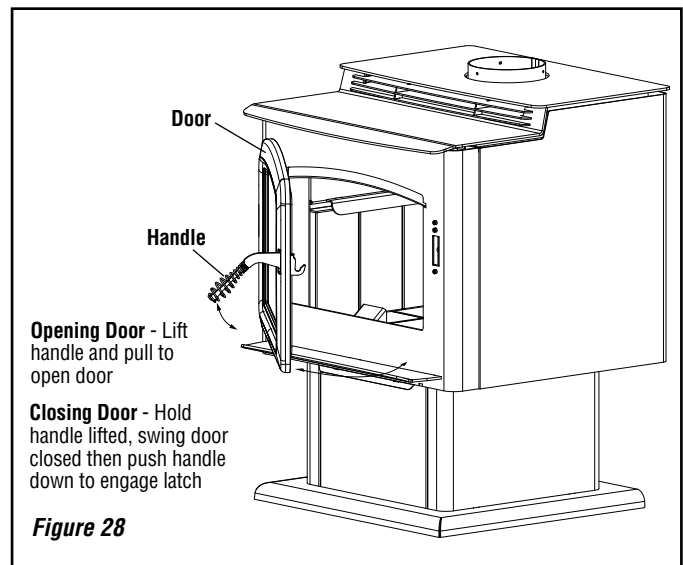

STARTING AND MAINTAINING A FIRE

1. **NEVER USE FLAMMABLE LIQUIDS TO START OR REKINDLE A SOLID FUEL FIRE!!**
2. Fully open the primary draft control by placing draft control (wood handle located on left side of the stove) in the highest position. This control determines the amount of air entering the stove. Lowering this control reduces the burn rate of the stove. For your convenience, the control is marked with five positions to assist you in obtaining repeatable burn rates.
3. Place a small amount of crumpled paper in the front of the firebox and cover it with a few pieces of kindling.
4. Light the paper and allow sufficient time for the kindling to become fully engulfed in flames. You will now close the wood units front door. Your wood units front door may or may not need to be left slightly open during this start up process, this depends on the stove model and the amount of draft present.
5. **When operating any wood burning appliance, it is important to become familiar with how the damper control affects heat output and the overall temperature of the appliance. A stove thermometer can be a helpful tool to help ensure you are not over-firing your appliance and it will also ensure you are burning fuel at a rate that is most efficient. Place a stove thermometer on the top of the appliance as shown in *Figure 29*. Monitor the temperature every 15 minutes or so until you become more familiar with your appliance. Close the damper all the way down if you begin to reach 500 degrees, as this is a sign that you are operating your appliance at too high a temperature.**

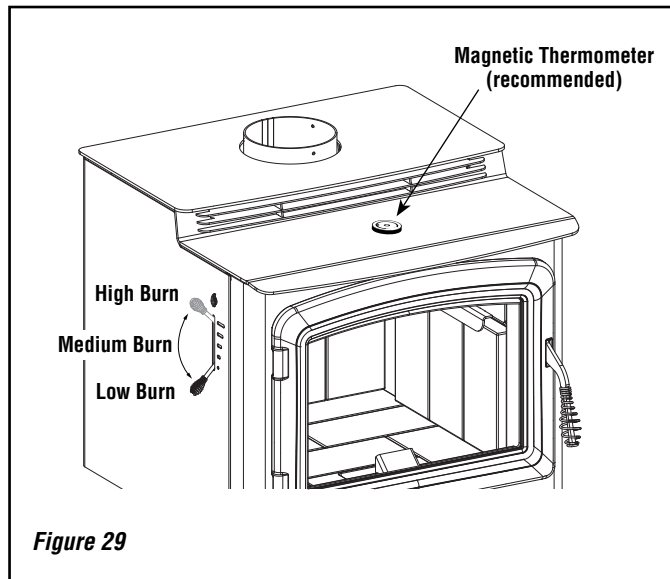

DO NOT LEAVE THE STOVE UNATTENDED WHILE THE FRONT DOOR IS SLIGHTLY OPEN.

CAUTION: Do Not alter the adjustment range of the draft control for increased firing for any reason.

Operate only with fuel door and ash drawer closed. Maintain all seals in good condition. Do not operate with broken glass.

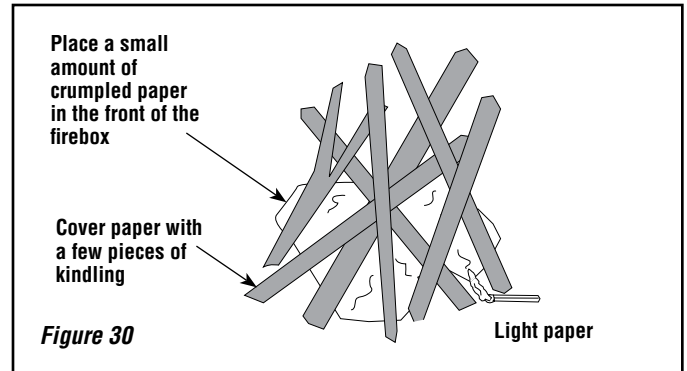

SEE MAINTENANCE SECTION FOR GLASS CLEANING GUIDELINES AND TIPS FOR KEEPING THE GLASS CLEAN (PAGE 28).

6. Once kindling is burning well, larger pieces of wood may be added, then the door should be fully closed if there was the need to keep it slightly open during start up.
7. For best results, use smaller pieces of wood to get the appliance temperature very high before loading larger wood for sustained burns. If necessary, crack the door to allow ignition of the fuel charge. Now you can add larger pieces of wood and after several minutes of high burn, set the left control for the desired heat output. Check the exhaust in about 15 to 20 minutes (*see Figure 32*). Large amounts of smoke indicate an improper burn setting (either too high or too low). Adjust and recheck in 5 to 10 minutes.

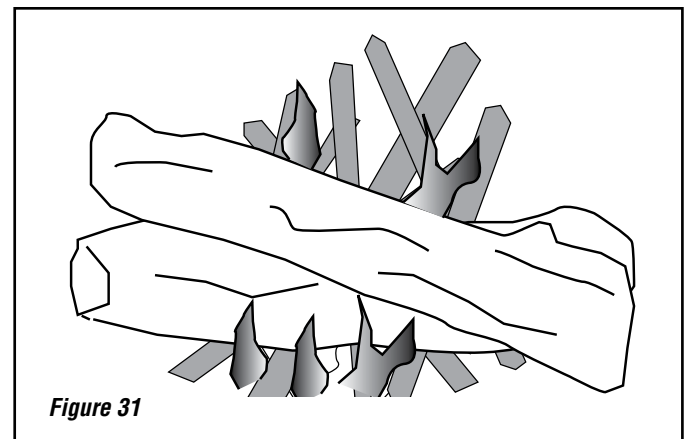

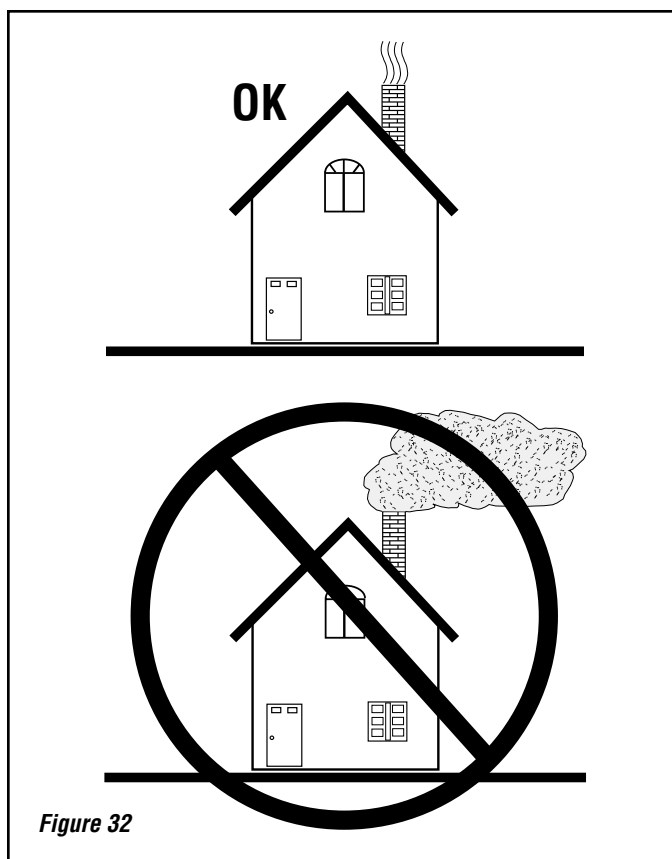

What does “Well-Seasoned” mean?

When a tree is cut down, the wood is green, full of sap and moisture. This moisture content can exceed 80%, which must be reduced to less than 20%. Wood properly seasoned is then capable of generating the heat the stove was designed to provide.

Green wood does not burn easily. Attempting to burn green wood often results in a lot of smoke and very little fire. Time is the most important factor in seasoning wood. Ideally the moisture content should be reduced to 11-20%. **NOTE: The use of a firewood moisture meter is recommended to ensure the firewood contains less than 20% moisture.**

Seasoning Guide

Softwoods - 6 months to 18 months
 Hardwoods - 12 months to 24 months

Logs that are 5” diameter across or larger should be split in half, three pieces if over 8 inches, and four pieces when over a foot across. If a tree has been dead for 2 - 4 years it still needs to be cut, split, and seasoned for 6 to 24 months depending on the wood.

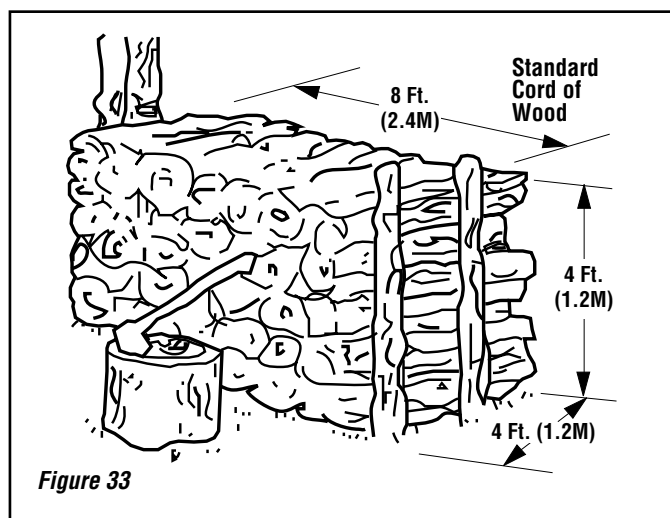

FUEL

This appliance is designed to burn dry seasoned natural wood only (see Page 26 for a list of prohibited fuels). Failure to burn proper fuels only will void the certification and the warranty of the appliance.

Dry, seasoned wood is that which has been cut, split and allowed to dry under a covered area where air is free to flow and circulate under and around the wood (not under a tarp or plastic). Make sure wood is not stacked directly on the ground, it may absorb moisture from the ground. It should be allowed to dry in these conditions for a minimum of six months, preferably one year or more. **IT MUST BE UNDERSTOOD THAT WOOD CANNOT BE LEFT IN ANY KIND OF WET OR DAMP AREA OR IT WILL NEVER BECOME COMPLETELY SEASONED.**

Do Not store fuel within space heater installation clearances or within the space required for refueling and ash removal.

DO NOT OVERFIRE THIS HEATER

Attempts to achieve heat output rates that exceed heater design specifications can result in permanent damage to the heater.

GETTING THE MOST OUT OF YOUR STOVE

Recent developments in wood-burning technology have made wood-burning a cleaner and more convenient way to heat your home. Overall efficiency in a wood-burning appliance is a combination of combustion efficiency and heat transfer efficiency. Whether heating your entire home or just a room or two, your understanding of how to best operate your stove or insert will enhance its overall efficiency and performance. What this can mean to you is longer, cleaner burns, less wood use and more heat.

The following sections will outline techniques you can use to “get the most out of your stove.” Please read them carefully.

MAXIMIZING YOUR STOVE’S OVERALL EFFICIENCY

It is important to know that for clean highly efficient burns you will need to have sufficient temperatures inside the firebox for thorough combustion. The best method for determining if you have sufficient temperatures is to watch the brick lining in your firebox. When you first light your stove or fireplace insert, the firebrick will turn a dark brown or black. After 20 to 30 minutes of a hot fire, most of the bricks should return to near their original beige color. This means the firebrick have reached a high enough temperature for your stove to achieve high combustion efficiency and you are ready to adjust the draft control to a lower setting.

Second and just as important, is achieving a high level of heat transfer efficiency. Slowing the rate of flow through the stove or insert enhances heat transfer, thus allowing more time for heat to be transferred into your home. To do this, be sure to thoroughly preheat your stove and then reduce the amount of primary air by closing the draft control down to a lower setting. (More air may produce a slightly greater amount of heat, but will greatly increase wood consumption).

To get the most out of your appliance, you will need to combine good combustion efficiency with good heat transfer practices. The following are some tips on how to operate your stove to achieve the highest overall efficiency.

1. Thoroughly preheat your stove before slowing the burn rate by closing the draft control.
2. When loading wood into a preheated stove or fireplace insert, allow a vigorous fire to build before lowering the draft control.
3. Operate your stove as much as possible in the low to medium burn ranges.
4. Do not lower the draft setting so low as to completely extinguish the flames in the firebox. Check for at least some small flames twenty minutes after setting the draft control.
5. Do not continually operate your stove or fireplace insert in the high (wide open) setting. This wastes wood by carrying a great deal of heat up the chimney and can damage your stove or fireplace insert and chimney.
6. Go outside and check your chimney. More than a very small amount of smoke indicates wasted heat, creosote build up and pollution (*see Figure 32*).

ACHIEVING CLEAN, LONG BURNS

To achieve long burn times, after having thoroughly preheated the stove, load the firebox without blocking the small air opening found in the center front of the firebox. At this point, you may need to burn the stove with the draft open for a few minutes to ignite the wood. All IHP stoves are EPA tested for emissions at low burn with the air control completely closed. Whether or not you should burn your stove with the air control completely closed will depend on the following factors:

- How you load your wood
- Your chimney type, height and draft
- Your wood type and its moisture content
- The temperature of the appliance
- Which model stove or insert you have

In order to maximize the burn time of your stove you may need to experiment to get the right balance of starting temperature, wood type, and draft control setting for your particular venting configuration. Do not reload the stove for long burns when the stainless secondary tubes or baffles are glowing red, or when the stove is uncomfortably hot to load. This indicates the stove is too hot to load for a long burn.

BLOWER OPERATION (OPTIONAL KIT)

Blower Operation

The blower can be operated in either manual or automatic mode. When operated automatically, the blower will turn on when the stove is hot, and turn off when the stove is cool.

— **MANUAL OPERATION:** Flip blower mode switch to the manual position (up) and adjust blower speed dial to desired setting. To turn blower off, rotate blower speed dial counter clockwise until it clicks “off.”

≡ **AUTO OPERATION:** Flip blower mode switch to auto position and turn blower speed dial clockwise until it clicks out of the “off” position. When the stove warms up (approx. 15-20 Mins), the blower will automatically turn on (adjust blower speed dial to desired speed setting). When the stove or insert cools down, the blower will automatically turn off.

Blower Operation Guidelines

While in auto operation mode, the blower will turn off and on based on The temperature of the appliance. Auto operation ensures there is sufficient heat build-up to warm the air being moved by the blower before the blower is turned on. Likewise, when the stove cools off, the blower is turned off to prevent circulating cool air. Depending on the size and intensity of the fire it may be necessary to adjust the fan speed accordingly to ensure uninterrupted fan operation. For example a small fire may require a slower fan speed to keep the heat output by the fan consistent. If the blower is operated in manual mode, it may be necessary to adjust the blower speed as the fire begins to burn down and the stove is no longer hot enough to effectively heat the air moved by the blower. If the air coming from the blower feels cool, one should either decrease the blower speed or stoke the fire to build up more heat.

NOTE: Turn blower off before opening the door to load the fuel.

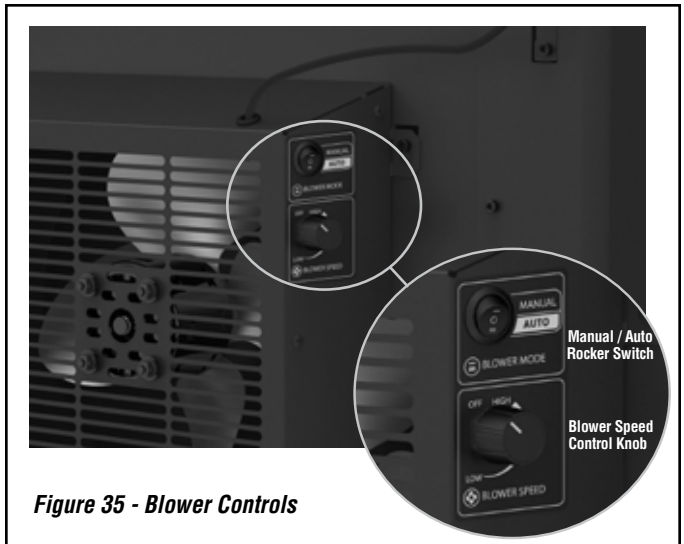

Figure 35 - Blower Controls

⚠ WARNING

The blower must be plugged directly into a properly grounded three-prong receptacle, 120 VAC, 60 Hz, single phase. Do not cut or remove the grounding prong from this plug. Do not route power cord under or in front of appliance.

Installation must be in accordance with National Electrical Code, ANSI/NFPA 70 - latest edition. In Canada, the current CSA C22.1 Canadian Electrical Code - latest edition.

DANGER: Disconnect power before servicing blower.

In the event that you remove the blower for any reason, make sure a cover plate (available from IHP) is installed before using the heater. Excessive rear wall temperatures will result if the stove is burned without the cover plate. The cover plate is not necessary if a blower has never been installed because a knock-out will be in place to act as the cover.

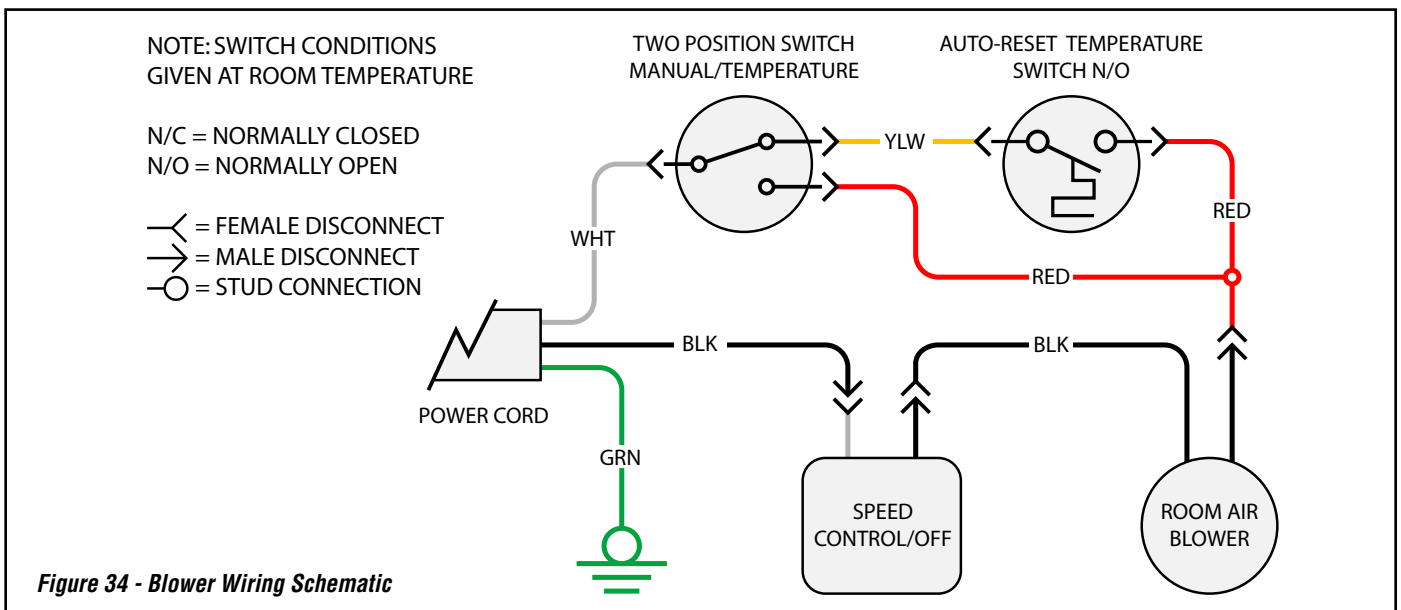

NOTE: DIAGRAMS & ILLUSTRATIONS ARE NOT TO SCALE.

DO'S AND DON'TS

- DO NOT:** Install or operate the appliance before reading this manual.
- DO NOT:** Close the draft beyond the point at which the flames are completely extinguished.
- DO NOT:** Open the appliance door without **fully opening** the draft first.
- DO NOT:** Burn driftwood or wood that has been in salt water. This includes some mill ends and scrap lumber that has been floated in salt water on the way to the mill. (This will void your warranty).
- DO NOT:** Handle the Nickel Door Trim unnecessarily. Use the door handle only.
- DO NOT:** Force oversized logs into the firebox as this may dislodge the baffle assembly.
- DO NOT:** Close the door tightly during Burn-In Period.

- DO:** Be sure to clean any fingerprints from optional accessories that have plated surfaces before burning the appliance. Clean the plated surfaces only with household type glass cleaner and a very soft cloth.
- DO:** Consult local building department if other than recommended clearances are desired.
- DO:** Read instructions for the baffle boards occasionally to ensure you have not bumped or moved them out of place when loading wood.
- DO:** Check the chimney and baffle monthly to make sure they are clean.
- DO:** Burn seasoned, dry wood only! (RAIN = WET WOOD)
- DO:** Open the door frequently during Burn-In Period to keep gasket from adhering to the curing paint.
- DO:** Enjoy the warm feeling of your new IronStrike® stove.

Smoke Detector Recommended

Since there are always several potential sources of fire in any home, we recommend installing smoke detectors. If possible, install the smoke detector in a hallway adjacent to the room (to reduce the possibility of occasional false activation from the heat produced by these appliances). If your local code requires a smoke detector be installed within the same room, you must follow the requirements of your local code. Check with your local building department for requirements in your area.

Carbon Monoxide Monitor Recommended

Carbon Monoxide Poisoning: Early signs of carbon monoxide poisoning are similar to the flu with headaches, dizziness and/or nausea. If you have these signs, obtain fresh air immediately. Some people are more affected by carbon monoxide than others, including pregnant women, people with heart or lung disease or anemia, those under the influence of alcohol, and those at high altitudes.

It is against federal regulations to operate wood heaters in a manner inconsistent with operating instructions in the manual.

PROHIBITED FUELS

This heater is designed to burn natural wood only. Higher efficiencies and lower emissions generally result when burning air dried seasoned hardwoods, as compared to softwoods or to green or freshly cut hardwoods. **DO NOT BURN:**

- **Garbage;**
- **Lawn clippings or yard waste;**
- **Materials containing rubber, including tires;**
- **Materials containing plastic;**
- **Waste petroleum products, paints or paint thinners, or asphalt products;**
- **Materials containing asbestos;**
- **Construction or demolition debris;**
- **Railroad ties or pressure-treated wood;**
- **Manure or animal remains;**
- **Salt water driftwood or other previously salt water saturated materials;**
- **Unseasoned wood;**
- **Christmas tree branches;**
- **Paper products, colored paper, cardboard, plywood, or particle-board;**
- **gasoline;**
- **naphtha;**
- **engine oil;**
- **flammable liquids;**
- **solvents;**
- **grease; or**
- **coal**

The prohibition against burning these materials does not prohibit the use of fire starters made from paper, cardboard, saw dust, wax and similar substances for the purpose of starting a fire in an affected wood heater.

Burning these materials may result in release of toxic fumes or render the heater ineffective and cause smoke. Intense firing with these materials may overheat the fireplace, causing damage to the unit, a fire or even possibly igniting a chimney fire if the chimney is creosoted. Burning unapproved fuel, resulting in excessive pollutants being emitted, may be prohibited and subject to a fine or other penalty by the authority having jurisdiction in your area.

MAINTENANCE

Have your product inspected at least once a year by a qualified service technician to ensure gaskets, air tubes, baffles, and venting are in good repair to ensure proper performance. Have degraded items replaced by a qualified service technician.

THIS WOOD HEATER NEEDS PERIODIC INSPECTION AND REPAIR FOR PROPER OPERATION. IT IS AGAINST FEDERAL REGULATIONS TO OPERATE THIS WOOD HEATER IN A MANNER INCONSISTENT WITH OPERATING INSTRUCTIONS IN THIS MANUAL.

DOOR HINGES: If door hinges need lubricating, use an anti-seize compound (never use oil) available from your IHP dealer.

DOOR LATCH: Adjustment Instructions - Remove the right side heat shield by loosening the 3 screws located on the back of the stove. Using a "L" shaped 5/32" allen wrench, loosen the locking screw in the latch assembly as shown in **Figure 37**. With the locking screw loosened, adjust the top 5/32" allen screw (**Figure 37**) in the front of the stove to adjust the door tension. Turning the screw to the right will tighten the door, turning the screw to the left will loosen the door. When you loosen the door it will be easiest to pull the roller pin to the full forward position and make slight adjustments to tighten to the desired tension. Assure that the tension on the front door creates a good seal between the gasket on the front door and the firebox front. After adjusting the door tension, re-tighten the lock screw and replace the heat shield.

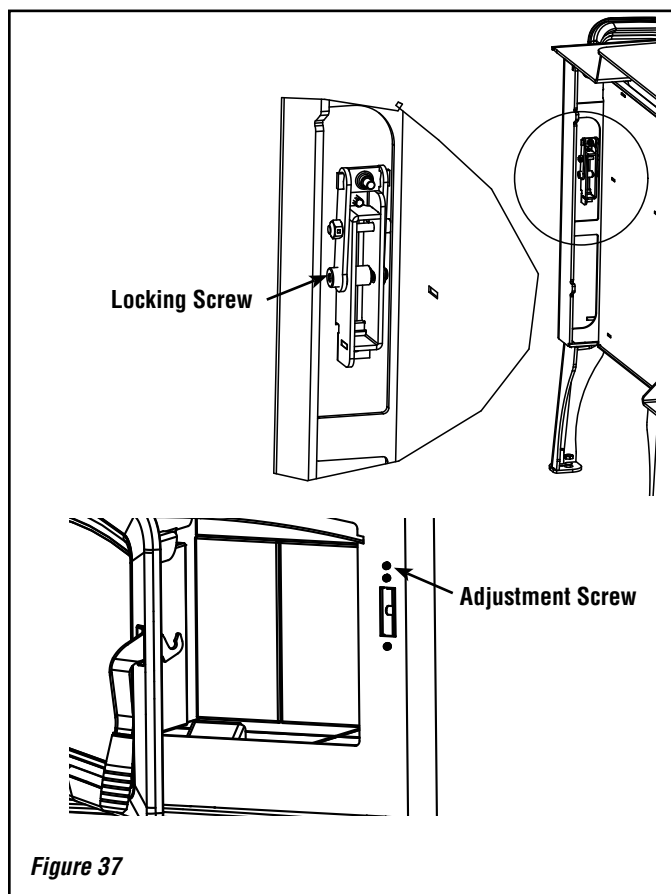

Figure 37

DOOR GASKET: Periodically check gasket to make sure it is not over-compressed. If compressed, replace with a special woven door rope. (Don't try substituting rope, only use IHP door rope).

PLATED ACCESSORIES: Clean only with household type glass cleaner and a very soft cotton cloth. Other products may damage plated finish, paint and gaskets.

BAFFLE BOARDS: Your baffle boards should be inspected during every chimney cleaning. If either board is damaged then replace baffle boards.

CREOSOTE FORMATION AND NEED FOR REMOVAL

When wood is burned slowly, it produces tar and other organic vapors, which combine with expelled moisture to form creosote. The creosote vapors condense in the relatively cool chimney flue of a slow-burning fire. As a result, creosote residue accumulates on the flue lining. When ignited, this creosote makes an extremely hot fire.

The chimney and chimney connector should be inspected at least once monthly during the heating season to determine if a creosote buildup has occurred. If creosote has accumulated (1/8" [3 mm] or more), it should be removed to reduce the risk of a chimney fire.

Establish a routine for the fuel, wood burner and firing technique. Check daily for creosote build-up until experience shows how often you need to clean to be safe. Be aware that the hotter the fire the less creosote is deposited, and weekly cleaning may be necessary in mild weather even though monthly cleaning may be enough in the coldest months. Contact your local municipal or provincial fire authority for information on how to handle a chimney fire. Have a clearly understood plan to handle a chimney fire.

DISPOSAL OF ASHES

Whenever ashes get 3 to 4 inches deep in your firebox, and when the fire has burned down and cooled, remove excess ashes. Leave an ash bed approximately 1 inch deep on the firebox bottom to help maintain a hot charcoal bed.

Ashes should be scooped out of a cool stove or fireplace insert with a small metal shovel. Ashes should be placed in a steel container with a tight fitting lid and moved outdoors immediately. Other waste shall not be placed in this container. The closed container of ashes should be placed on a non-combustible floor or on the ground, well away from all combustible materials, pending final disposal. If the ashes are disposed of by burial in soil or otherwise locally dispersed, they should be retained in the closed container until all the cinders have thoroughly cooled. Ashes can ignite up to 72 hours after removal from the appliance.

WARNING

Inspect and clean chimney and connector frequently. Under certain conditions of use, creosote buildup may occur rapidly.

MAINTENANCE

GLASS REPLACEMENT INSTRUCTIONS

(Refer to *Figure 36*)

- Step 1. Remove Door Assembly** - Remove the upper and lower hinge pins by pressing the bottom of each hinge pin up, then pull out from the top. Lift off door and place face down on a soft surface.
- Step 2. Remove Glass Retainer Screws (10 ea.)** - Using an 1/8" allen wrench remove the ten glass retainer screws. To locate screws, peel back the door gasket as necessary. The screws are located by the holes in the stainless steel glass retainer strips.
- Step 3. Remove Glass** - Carefully remove broken glass one piece at a time (protective leather gloves are recommended).
- Step 4. Clean Door Frame** - Clean the area of the door frame where the new glass with gasket will be installed.
- Step 5. Install New Glass Assembly** - Install the new glass with gasket (use only factory supplied 5mm ceramic glass with gasket. **Do not substitute**).
- Step 6. Reinstall Retainer and Screws** - Carefully reinstall the glass retainer and screws. Be very careful not to overtighten the screws (this could result in glass breakage when the stove is hot).
- Step 7. Reinstall Door** - Align hinges on door frame with corresponding hinge holes on the face of stove. Reinstall the upper and lower hinge pins from the top.

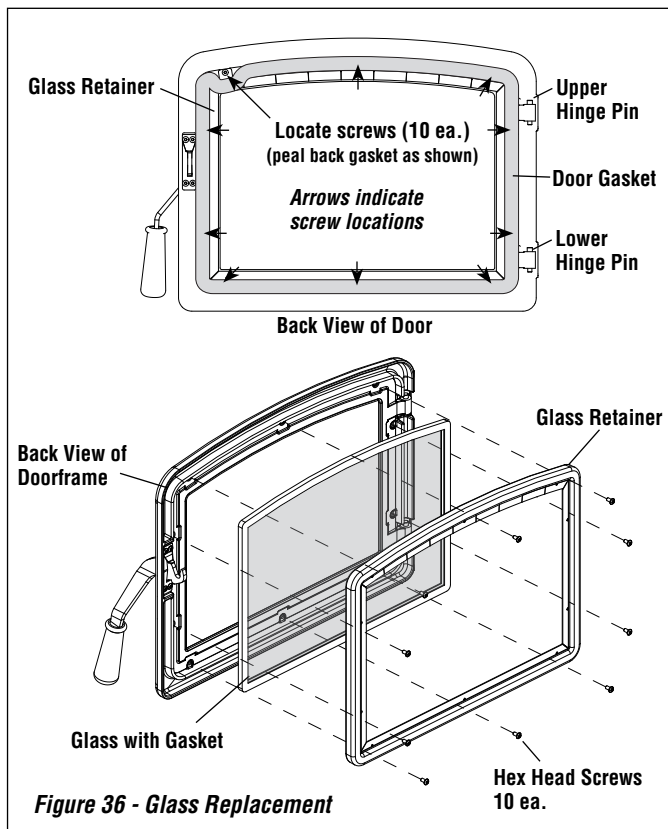

GLASS CLEANING GUIDELINES

WARNING: DO NOT CLEAN GLASS WHEN APPLIANCE IS HOT!

Glass on any wood stove will not stay perfectly clean. Here are some guidelines for cleaning and caring for the glass:

- **Ensure the stove is cold prior to cleaning glass.**
- This appliance is designed to provide a flow of air over the inside of the glass, where along with high heat helps inhibit build-up on the glass. When build-up occurs, a commercial glass cleaner designed for stoves is recommended. Regular household glass cleaners will not clean creosote.
- Do not use abrasives such as steel pads, steel wool or oven cleaner as they will scratch the glass. Never scrape glass with a razor blade as this may pit the glass and make it impossible to clean in the future.
- Do not use chemical glass cleaners as they may damage the gaskets or painted surfaces.

TIPS FOR KEEPING THE GLASS CLEAN

- Burn only dry seasoned cord wood. **Wet wood = Dirty glass.**
- A short, hot fire (15 - 20 minutes) may help to clean off some of the normal buildup. **Lower burns = more build-up. Higher burns = less build-up.**
- Keep freshly loaded wood away from the glass.
- After reloading, allow all the wood to catch flame before dampering down the stove.

⚠ CAUTION

Cleaning Glass: Ensure appliance is cold prior to cleaning glass. A commercial glass cleaner designed for stoves is recommended. Do not use abrasive cleaners. Do not clean with any materials, which may scratch or otherwise damage the glass. Scratches on the glass can develop into cracks or break. Inspect the glass regularly. If you detect a crack, extinguish the fire and contact your dealer for a replacement.

TROUBLESHOOTING

Problem	Solution
POOR DRAFT:	Extend chimney in length or have the chimney realigned to the proper size flue. Oversized chimneys normally have poor drafts. Remember, the appliances' draft depends solely on the natural draft of the chimney (See Draft Requirements on Page 4). If your stove or fireplace insert is not drafting properly, your chimney is the problem. All stoves are thoroughly tested to ensure proper draft with the correct size chimney flue.
EXCESSIVE DRAFT:	With better chimneys being more common, excessive draft can be an issue. Alleviate excessive draft by slowing the burn rate of the appliance once it has reached proper operating temperature (See Maximizing Your Stoves Overall Efficiency on Page 24).
DIRTY GLASS:	<ol style="list-style-type: none">1) Burn smaller, hotter fires and check to make sure you are not setting the draft down too far with the draft control.2) Make sure your wood is well-seasoned and dry (not open to rain - see Creosote [Page 27] and Fuel [Page 23] sections).3) See Poor Draft section (above) and Cleaning Glass on Page 29.
SMOKES WHEN DOOR IS OPEN:	<ol style="list-style-type: none">1) If smoke is entering the room, check to make sure your baffle boards are properly installed.2) Check the chimney for blockage due to creosote (see Chimney [Page 4] and Creosote [Page 28] sections).3) Check draft (See POOR DRAFT section above).
WOOD BURNS TOO FAST:	<ol style="list-style-type: none">1) The draft control must be closed further.2) Add fuel at lower firebox temperatures.3) Load wood side to side and reduce the flow of air under wood.4) The door seal may need replacing, check for leakage.5) See "Excessive Draft."
POOR HEAT OUTPUT:	<ol style="list-style-type: none">1) Check your wood. Wet, moist, unseasoned wood will not produce heat.2) Your stove or fireplace insert needs to be seasoned (moisture removed from the steel and brick). Continue to burn a fire. It normally takes from one to three weeks of burning to season your stove (See Burn-In procedures on Page 21).3) See Excessive Draft section above.
PAINT GIVES OFF ODOR (smoke):	Paint is tempering-in. Burn only moderately hot for the first few days until paint is fully cured. Then burn a very hot fire to cure any paint that may not easily cure. Open windows or door to ventilate (See Burn-In Period on Page 21).

REPLACEMENT PARTS - MODELS GRANDVIEW™ 230 AND 300

Contact an IHP dealer to obtain any of these parts. Never use substitute materials. Use of non-approved parts can result in poor performance and safety hazards.

FRONT DOOR PARTS LIST			
Item #	Description	GV230	GV300
1	Inner Door Frame, Cast Iron	H8365	
2	Outer Door Frame, Cast Iron	H8366	
3	Glass Gasket 1"	H8380	
4	Door Gasket 7/8"	H5639	
5	Ceramic Glass With Gasket	H8392	
6	Door Handle Kit	H8395	
7	Door Latch Assembly (4 button head screws and latch)	H8397	
8	Glass, Retainer Kit	H8394	
9	Door Hardware Kit (includes 2 pins, door roller and 10 button head screws and door set screw)	H8398	
LEG PARTS			
10	Coastal Brushed Nickel Leg - single leg	H8383	
10	Coastal, Nickel Leg - single leg	H8384	
10	Coastal, Black Leg - single leg	H8385	
11	Lakeview, Steel Black Leg - single leg	H8386	
---	Olympic, Brushed Nickel Cast Leg - single leg	H5619	
---	Olympic, Nickel Cast Leg - single leg	H5621	
---	Olympic, Black Cast Leg - single leg	H5669	
---	Leg, Hardware, Bolt, Kit	H8382	
PEDESTAL PARTS			
14	Ash Plug Remover and Rake	H5564	
15	Removable Ash Plug	H8381	

BLOWER PARTS			
Item #	Description	GV230	GV300
16	Blower Snap Switch	H8374	
17	Blower Blade	H8375	
18	Blower Cover	H8376	
19	Speed Control - High Temperature	H5742	
20	Blower Rocker Switch	H8066	
---	Blower Opening Cover Plate	H8399	
22	Blower Power Cord	H5660	
MISCELLANEOUS PARTS			
---	Dry Graphite (apply to door handle bushing)	71052	
---	Anti Seize, 2 Gram Pouch	H5633	
23	Heat Exchanger Bolt Kit	H8387	
---	Flue Ring Bolt Kit	H8388	
---	Ash Drawer Hardware Kit	H8389	
---	Taptite Qty 8 (34055)	H8390	
---	Button Head Screw Qty 8 (34027)	H8391	
FIREBOX PARTS			
---	Secondary Tube Retainer Clips	H8367	
---	Replacement Secondary Air Tube Kit	H8373	H9081
24	Back Brick Retainer	---	J7602
27	Complete Firebrick Kit (GV230 - 20 bricks included, GV300 - 26 bricks included)	H8378	H9082
28	Firebrick 4-1/2" X 9", Each	H5612	
29	Baffle Board Kit	H8379	H9083
BODY PARTS			
30	Damper Rod	H8393	
31	Damper Assembly	H8396	
32	Stove Top Replacement	H8368	H9084
33	Cast Iron Heat Exchanger (hardware included)	H8369	H9085
35	Left Side Heat Shield (hardware included)	H8370	H9086
34	Right Side Heat Shield (hardware included)	H8371	H9087
36	Rear, Heat, Shield (hardware included)	H8372	H9088
37	Heat Exchanger Gasket	H8377	

REPLACEMENT PARTS - MODELS GRANDVIEW™ 230 AND 300

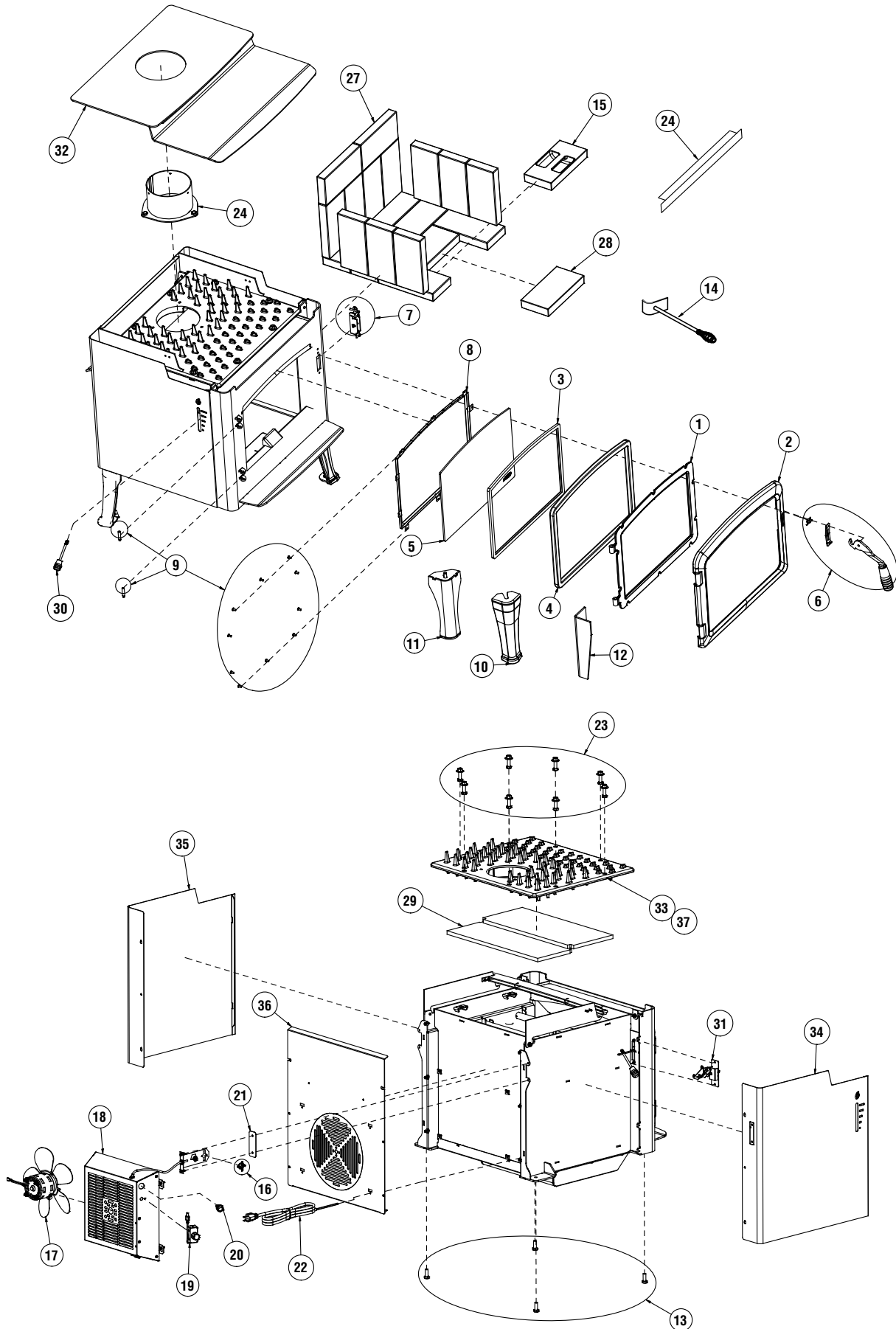

NOTE: DIAGRAMS & ILLUSTRATIONS ARE NOT TO SCALE.

ACCESSORIES - MODELS GRANDVIEW™ 230 AND 300

PEDESTAL (REQUIRED)				
Item #	Model	Description	GV230	GV300
1	PED-GV	Pedestal, Black	H8343	
OR LEGS (REQUIRED)				
2	LEG-COSTL-BLK	Coastal Legs, Black	H8339	
2	LEG-COSTL-BRNKL	Coastal Legs, Brushed Nickel	H8340	
2	LEG-COSTL-NKL	Coastal Legs, Nickel	H8341	
3	LEG-LKVIEW-BLK	Lakeview Legs, Black	H8342	
4	LEG-OLY-B	Olympic Sculptured Black	70000	
4	LEG-OLY-N	Olympic Sculptured Nickel	70002	
4	LEG-OLY-BRN	Olympic Sculptured Brushed Nickel	70008	
ASH DRAWERS				
5	ASHDR-KIT-PED-GV	Pedestal, Ash Drawer Kit	H8344	
6	ASHDR-KIT-LEG-GV	Leg, Ash Drawer Kit	H8345	
LOUVERS				
7	LVP-GV230-BLK	Louvers, Black	H8348	H8959
7	LVR-GV230-BRNKL	Louvers, Brushed Nickel	H8349	H8960

DOOR TRIM				
Item #	Model	Description	GV230	GV300
8	DRTRM-GV230-NKL	Door Trim, Nickel	H8346	
8	DRTRM-GV230-BRNKL	Door Trim, Brushed Nickel	H8347	
BLOWER				
9	BLWR-GV-700-SS	Blower	H8350	
OUTSIDE AIR KITS				
10	UZIAD	Outside Air Coupler for Connection of UZI to Fireplace	UZIAD	
11	UZI	Outside Air Kit (4" I.D. x 10 ft. long insulated flex)	UZI	
COMMON ACCESSORIES				
12	TSPK-B	Touch-up Spray Paint Kit, Black	H8159	
13	WP-LEGF-LBRKT	Leg Tie Down Kit, Coastal & Lakeview Legs, Mobile Homes	H7665	
14	W-LEGF-LBRKT	Leg Tie Down Kit, Olympic Legs, Mobile Homes	H5308	
15	BELLA-LLK	Leg Leveling Pads	H7638	
----	W-LLK	Leg Leveling Bolt Kit	H8407	

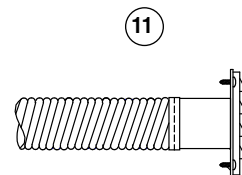
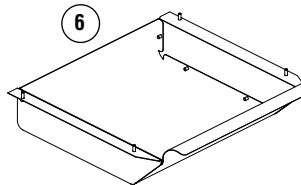
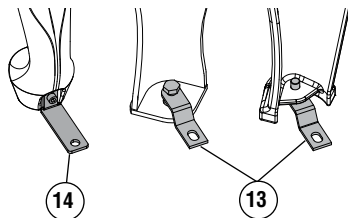
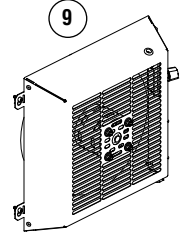
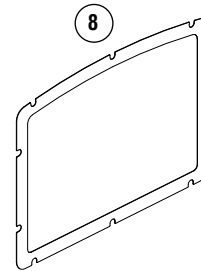
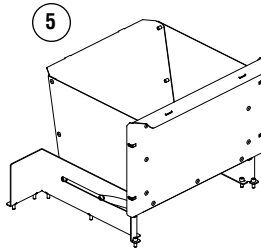
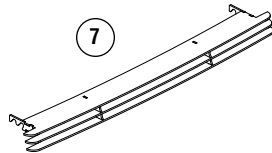
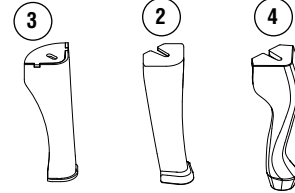
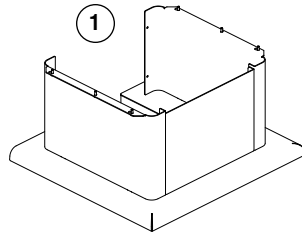
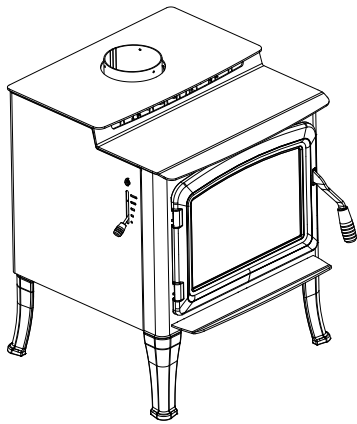

Innovative Hearth Products IronStrike™ Brand Wood Burning Stove and Insert Limited Lifetime Warranty

THE WARRANTY

Innovative Hearth Products ("IHP") Limited Lifetime Warranty warrants your IronStrike™ Brand Wood Burning Stove or Insert ("Product") to be free from defects in materials and workmanship at the time of manufacture. The Product body, firebox and ceramic glass carry the Limited Lifetime Warranty. Ceramic glass carries the Limited Lifetime Warranty against thermal breakage only. After installation, if covered components manufactured by IHP are found to be defective in materials or workmanship during the Limited Lifetime Warranty period and while the Product remains at the site of the original installation, IHP will, at its option, repair or replace the covered components. If repair or replacement is not commercially practical, IHP will, at its option, refund the purchase price or wholesale price of the IHP product, whichever is applicable. IHP will also pay IHP prevailing labor rates, as determined in its sole discretion, incurred in repairing or replacing such components for up to five years. THERE ARE EXCLUSIONS AND LIMITATIONS to this Limited Lifetime Warranty as described herein.

COVERAGE COMMENCEMENT DATE

Warranty coverage begins on the date of installation. In the case of new home construction, warranty coverage begins on the date of first occupancy of the dwelling or six months after the sale of the Product by an independent IHP dealer/distributor, whichever occurs earlier. The warranty shall commence no later than 24 months following the date of product shipment from IHP, regardless of the installation or occupancy date.

EXCLUSIONS AND LIMITATIONS

This Limited Lifetime Warranty applies only if the Product is installed in the United States or Canada and only if operated and maintained in accordance with the printed instructions accompanying the Product and in compliance with all applicable installation and building codes and good trade practices.

This warranty is non-transferable and extends to the original owner only. The Product must be purchased through a listed supplier of IHP and proof of purchase must be provided. The Product body and firebox carry the Limited Lifetime Warranty from the date of installation. Vent components, trim components and paint are excluded from this Limited Lifetime Warranty. The following do not carry a Limited Lifetime Warranty but are warranted as follows:

Cast Iron Heat Exchanger – Replacement for five years from the date of installation

Cast iron parts – Replacement for one year from the date of installation

Catalyst – Carries a separate warranty. Refer to the warranty certificate provided for that part

Electrical components – Repair or replacement for one year from date of installation

Gaskets – Replacement for one year from the date of installation.

Gold & nickel plating – Replacement for two years from date of installation. Excludes tarnishing

Refractory & screens – Replacement for two years from date of installation. Excludes hairline cracks

Removable air tubes – Repair or replacement for seven years from date of installation. IHP prevailing labor rates for years one through five.

Labor coverage – Prevailing IHP labor rates apply for the warranty period of the component, unless otherwise noted

Parts not otherwise listed carry a 90 day warranty from the date of installation.

Whenever practicable, IHP will provide replacement parts, if available, for a period of 10 years from the last date of manufacture of the Product.

IHP will not be responsible for: (a) damages caused by normal wear and tear, accident, riot, fire, flood or acts of God; (b) damages caused by abuse, negligence, misuse, or unauthorized alteration or repair of the Product affecting its stability or performance. (The Product must be subject to normal use with approved fuels listed in the Operation Manual provided with the product. Fuel products with abnormal burning characteristics, including but not limited to fuel such as driftwood, coal or plywood and wood products using a binder may burn at excessive temperatures and may cause damage to the Product or may cause it to function improperly; IHP stoves, inserts and high efficiency EPA fireplaces are approved for burning dry seasoned wood only.); (c) damages caused by failing to provide proper maintenance and service in accordance with the instructions provided with the Product; (d) damages, repairs or inefficiency resulting from faulty installation or application of the Product.

Coverage of this Limited Lifetime Warranty is conditional upon the appliance being operated without the use of grates, irons or any other method to elevate the fire.

IHP is not responsible for inadequate system draft caused by air conditioning and heating systems, mechanical ventilation systems, or general construction conditions which may generate negative air pressure in the room in which the appliance is installed. Additionally IHP assumes no responsibility for smoking conditions caused by inadequate chimney height, adjoining trees or buildings, adverse wind conditions or unusual environmental factors and conditions. Certain IHP Products are listed for use with Security Chimneys International, Ltd. chimney systems only. Use of chimney components other than that specified in the Product manual will void the Product warranty.

This Limited Lifetime Warranty covers only parts and labor as provided herein. In no case shall IHP be responsible for materials, components or construction which are not manufactured or supplied by IHP or for the labor necessary to install, repair or remove such materials, components or construction. Additional utility bills incurred due to any malfunction or defect in equipment are not covered by this Limited Lifetime Warranty. All replacement or repair components will be shipped F.O.B. from the nearest stocking IHP factory.

LIMITATION ON LIABILITY

It is expressly agreed and understood that IHP's sole obligation and the purchaser's exclusive remedy under this warranty, under any other warranty, expressed or implied, or in contract, tort or otherwise, shall be limited to replacement, repair, or refund, as specified herein.

In no event shall IHP be liable for any incidental or consequential damages caused by defects in the Product, whether such damage occurs or is discovered before or after replacement or repair, and whether such damage is caused by IHP's negligence. IHP has not made and does not make any representation or warranty of fitness for a particular use or purpose, and there is no implied condition of fitness for a particular use or purpose.

IHP makes no expressed warranties except as stated in this Limited Lifetime Warranty. The duration of any implied warranty is limited to the duration of this expressed warranty.

No one is authorized to change this Limited Lifetime Warranty or to create for IHP any other obligation or liability in connection with the Product. Some states and provinces do not allow the exclusion or limitation of incidental or consequential damages, so the above limitations or exclusions may not apply to you. The provisions of this Limited Lifetime Warranty are in addition to and not a modification of or subtraction from any statutory warranties and other rights and remedies provided by law.

INVESTIGATION OF CLAIMS AGAINST WARRANTY

IHP reserves the right to investigate any and all claims against this Limited Lifetime Warranty and to decide, in its sole discretion, upon the method of settlement.

To receive the benefits and advantages described in this Limited Lifetime Warranty, the appliance must be installed and repaired by a licensed contractor approved by IHP.

Contact IHP at the address provided herein to obtain a listing of approved dealers/distributors. **IHP shall in no event be responsible for any warranty work done by a contractor that is not approved without first obtaining IHP's prior written consent.**

HOW TO REGISTER A CLAIM AGAINST WARRANTY

In order for any claim under this warranty to be valid, you must contact the IHP dealer/distributor from which you purchased the product. If you cannot locate the dealer/distributor, then you must notify IHP in writing. IHP must be notified of the claimed defect in writing within 90 days of the date of failure. Notices should be directed to the IHP Warranty Department at 1508 Elm Hill Pike, Suite 108; Nashville, TN 37210 or visit our website at WWW.IRONSTRIKE.US.COM.

WARRANTY

Your wood appliance is covered by a limited warranty (provided with the appliance). Please read the warranty to be familiar with its coverage.

Retain this manual. File it with your other documents for future reference.

REPLACEMENT PARTS

See **Pages 30 and 31** for a complete replacement parts list. Use only parts supplied from the manufacturer.

Normally, all parts should be ordered through your IHP distributor or dealer. Parts will be shipped at prevailing prices at time of order.

When ordering repair parts, always give the following information:

1. The model number of the appliance.
2. The Serial Number of the appliance.

3. The part number.
4. The description of the part.
5. The quantity required.
6. The installation date of the appliance.

If you encounter any problems or have any questions concerning the installation or application of this system, please contact your dealer.

Innovative Hearth Products, LLC (IHP)
1508 Elm Hill Pike, Suite 108
Nashville, TN 37210
IronStrike.us.com

PRODUCT REFERENCE INFORMATION

We recommend that you record the following important information about your appliance. If you did not purchase your appliance directly from an IHP dealer, then contact us at IronStrike.us.com to find your nearest IHP dealer who will answer your questions or address your concerns.

Model Number	_____
Serial Number	_____
Date Installed	_____
Your Dealer's Name	_____

NATIONAL FIREPLACE INSTITUTE

CERTIFIED
www.nficertified.org

We recommend that our woodburning hearth products be installed and serviced by professionals who are certified in the U.S. by the National Fireplace Institute® (NFI) as NFI Woodburning Specialists or who are certified in Canada by Wood Energy Technical Training (WETT).

Wood Energy Technical Training
www.wettinc.ca

NATIONAL FIREPLACE INSTITUTE

CERTIFIED
www.nficertified.org

Nous recommandons que nos pôeles à bois soient installés et que l'entretien soit effectué par des professionnels certifiés, aux Etats-Unis par le National Fireplace Institute® (NFI) et au Canada, par le Wood Energy Technical Training (WETT).

Wood Energy Technical Training
www.wettinc.ca

IHP reserves the right to make changes at any time, without notice, in design, materials, specifications, and prices, and also to discontinue colors, styles, and products. Consult your local distributor for fireplace code information.

