

# HECO COOKSTOVE OWNER'S MANUAL

## 420 & 520 SERIES



BEFORE YOU INSTALL OR OPERATE A HECO COOKSTOVE YOU MUST READ ALL INSTRUCTIONS CAREFULLY & INSTALL SMOKE & CARBON MONOXIDE DETECTORS



# INTRODUCTION

Congratulations on the purchase of your new Heco Cookstove, we hope that you enjoy using it!

## Our Story

The Heco Cookstove originally started as an idea. Amos Stoltzfus, owner of Breeo, LLC, had a vision for a cookstove that would be easy to use, attractive, and last a lifetime. The idea for this cookstove gradually turned into a reality as the project transitioned from ideas, to drawings, to the actual fabrication process. The Heco Cookstove challenges an industry that has seen few improvements or modifications in the last 20 years, with many cookstoves remaining unchanged despite advances in clean burning technology. The clean lines and more simplistic, modern design of the Heco Cookstove is a part of the plan to truly bring innovation to the cookstove market. This stove burns wood or coal, allowing for unparalleled flexibility of fuel choices. The oven can be easily controlled for consistent baking and cooking temperatures. All of the exterior parts, with the exception of the cooktop in some cases, are porcelain coated for a beautiful, smooth finish. The Heco Cookstove is designed to be used for generations. Worn porcelain parts can easily be replaced and switched out for different options. For example, a customer can choose glass doors to add ambiance to the room the stove is in, or can easily switch to a solid door if they'd like to. The stove's designer, Amos Stoltzfus, has 20+ years of metal fabrication experience and 15+ years of stove design and production experience. The Heco Cookstoves are manufactured at Breeo's headquarters in Lancaster County, PA.

## INDEX

INTRODUCTION & INDEX	Page 2
SAFETY INSTRUCTIONS	Page 3
OPERATIONAL & WORK PRACTICE STANDARDS	Page 4,5
COOKSTOVE LOCATION	Page 6,7
CHIMNEY REQUIREMENTS	Page 8
OPERATION CONTROLS	Page 9
BAKING & COOKING CONTROLS	Page 10
DOMESTIC WATER OPTIONS	Page 11
EXHAUST CLEANOUT	Page 12
420 PARTS LIST	Page 13
420 FIREBRICK LIST	Page 14
520 PARTS LIST	Page 15
520 FIREBRICK LIST	Page 16
TROUBLESHOOTING	Page 17,18
WARRANTY	Page 19
CONTACT INFO	Page 20

# SAFETY INSTRUCTIONS

1. Read all instructions before installing or operating any Heco Cookstove.
2. You must install both smoke and carbon monoxide detectors before installing or operating your cookstove.
3. Check your local codes; this installation must meet their guidelines.
4. Do not open bottom ash door to increase draft; the ash door is designed for emptying ashes only.
5. Never leave Heco Cookstove doors open when the cookstove is unattended.
6. Do not hook cookstove up to an aluminum Type B gas vent. Use a code approved Class A chimney that has a 6" diameter (min) to 8" diameter (max), and is a minimum of 20' high.
7. Before you ignite your cookstove, be sure to inspect the chimney for any cracking or leaking liners, as this will affect the draft.
8. Clean the chimney before installing your cookstove. If creosote is attached to the liner, you will run the risk of a chimney fire.
9. Never leave children unsupervised while in the same room as the cookstove. To avoid injury, provide a sturdy barrier to keep children and pets a safe distance from the cookstove.
10. Keep cookstove area clear of all combustible materials, gasoline, and other flammable vapors and liquids.
11. Use the required floor protection shown on the safety listing located on the back of the cookstove.
12. Ensure the clearance to combustible walls and floors meet the requirements listed on page 7 of this manual.
13. Do not allow anyone who is unfamiliar with the cookstove to operate it.
14. Spend time becoming acquainted with the different settings on your cookstove and how each will affect its burning patterns. It is impossible to state exactly how each setting will affect your cookstove.
15. Be extremely careful when removing the ash pan from the cookstove. It may be extremely hot!
16. When replacing the baffle in the fire box, shut down the stove so the fire stops burning. *Cookstove with 3 Panel Tops* - once the cookstove has cooled, remove the left and center cooktop panels to provide access to the baffle. *Cookstove with Solid Steel Top* - once the cookstove has cooled, you can access the baffle through the fire door. The baffle is located above the reburn tubes at the top of the fire box.
17. Make sure your stove pipe has at least 3 screws per joint.
18. Do not install this cookstove in a mobile home or trailer.
19. Do not use a manual, barometric or automatic damper when burning wood.

# OPERATION & WORK PRACTICE STANDARDS

1. When burning wood, burn only dry, seasoned cord-wood, with 20% moisture content or less. Bring wood to room temperature before burning.
2. Keep wood covered in a wood shed or under a tarp.
3. Right after delivery: stack cord-wood under cover.
4. Split cord wood before drying.
5. Do not burn green wood; it needs to have no more than 20% moisture.
6. All firewood must be seasoned at least 1 year .
7. Check wood moisture at least once a week.
8. Keep a 2" to 3" ash layer on top of the grates when burning wood. Note: Do not cover louver vents.
9. The cookstove is designed to burn air-dried wood and coal at a predetermined firing rate. Over-firing occurs when the ash door is left open during operation or a highly volatile fuel ( i.e. large amounts of small kindling) is used. The surface of your cookstove should not exceed 800 degrees. If the surface does exceed 800 degrees, the warranty on the stove will be void.
10. Open firebox door slowly to avoid a "flashback".
11. When you load wood into the cookstove, fully open the draft until the new wood ignites and then set to normal burn; this will pre-heat the wood and the secondary re-burn will work more efficiently.
12. With new steel there is a small amount of oil and/or dirt on the metal so you may smell an odor. This is normal during the first operation. You may want to assemble the cookstove outside and build a small fire in it to "BURN OFF" this dirt and oil before installing the unit in your home.
13. Be extremely careful when removing the ash pan from the cookstove. It can get very hot!
14. Check the fit on the firebox door; It must fit tightly. If it does not, check for deterioration or wear of the ceramic rope seal. Replace defective seals.
15. Inspect and clean your chimney and stove pipe regularly.
16. In the event of a chimney fire, shut all cookstove draft controls, alert everyone in the house, and call your fire department immediately. If the flue is still burning vigorously, throw baking soda into the firebox or discharge a fire extinguisher into the firebox. After the chimney fire is over, have a certified chimney sweep completely inspect your system for damage before further use.
17. Slow fires: it is not recommended to burn the Heco Cookstove more than necessary early in the fall and late in the spring, as you cannot keep the fire box hot enough to burn gasses (without overheating your home). Slow fires can cause excessive creosote buildup in the firebox, stove pipe and chimney.
18. Equip your home with fire extinguishers, carbon monoxide detectors and smoke detectors.
19. Do not burn garbage, gasoline, or any other flammable liquids in your cookstove.
20. This is a wood and coal burning cookstove and should not be altered in any way. Altering the stove from the original design will void the warranty.

# OPERATION & WORK PRACTICE STANDARDS

## Testing Cookstove Draft Before Lighting

To test your draft, place a piece of newspaper inside the cookstove fire box and light it. Pay close attention to the direction of fire's flame and smoke. If the smoke is drawn up into the stove exhaust, your draft is working properly. If the smoke spills out the door, you do not have proper draft.

## Starting a Coal Fire

Remove the steel Wood Plate that sits on the grates inside the cookstove's fire box. This plate cannot be used when burning coal in the cookstove. Set oven bypass control to cooking mode. Fully open the Bimetal Regulator and Airwash Controls. Place crumpled paper and kindling on the bottom grate inside the fire box and ignite with a match or lighter. Use a small pile of kindling to get the fire started, adding larger pieces of wood to build up the heat of the fire. Once your fire is hot, add 2" of coal over the entire grate area. As the coal starts burning and glows red, add another layer of coal. Keep adding coal until you have an 8" body of fire. You can now add 30 lbs. of coal and adjust the draft on the Bimetal Regulator Control to meet your needs.

**NOTE:** You can also use charcoal briquettes as a fire starter.

## Maintaining a Coal Fire

Shake ashes every 12 hours if possible. You must keep your ashes cleaned out from underneath the grates; This may require emptying your ash pan daily. If there is no air space under the grates, they will warp and become inoperable.

## Starting a Wood Fire

Install the steel Wood Plate that sits on the grates inside the cookstove's fire box; this plate will hold up the ash bed of the fire. When starting a wood fire, use the steps listed above for starting a coal fire, but do not add coal. Allow ash to build up on top of the grates; this will not choke the fire until it covers the louver vents. Keep approximately 2" to 3" of ash on grates at all times. The airwash vents will work as the fire's primary air. Adjust the Airwash Control as needed to burn a fire that meets your needs.

## Creosote Formation & Removal

When wood is burned slowly, it can produce tar or other organic vapors, which, when combined with expelled moisture, will form creosote. The creosote vapors condense in the relatively cool chimney flue of a slow burning fire. As a result, creosote residue accumulates on the flue lining. When ignited, this creosote makes an extremely hot fire. The chimney connector and the chimney itself should be inspected at least twice a month, during the heating season, to determine if creosote buildup has occurred. If creosote has accumulated, the creosote should be removed immediately to reduce the risk of a chimney fire.

**NOTE:** the key for reducing creosote buildup is to burn a hot fire and use seasoned firewood. Firewood should be seasoned for one year with a moisture rating of no more than 20%. The wood should be cut, split and stacked under open shelter to dry. Stack the firewood indoors one day prior to burning it. Shutting primary air supply to the fire box will cause the fire to smolder, which will result in creosote accumulation.

## COOKSTOVE LOCATION

1. The cookstove must be located on a non-combustible floor. If you have a combustible floor, you are required to use a non-combustible floor board (Type 1 Board).
2. Review the plaque on the cookstove before installation. The most important consideration in installing your cookstove is adequate clearance between the stove and any combustible surface. A cookstove that is placed too close in proximity to a wall or furniture may cause a fire.
3. The hearth must extend out at least 15" from the front edge of the cookstove, 8" from the rear of the cookstove, and 8" from the left side of the cookstove. It also must run underneath and extend 2" beyond either side of the stove pipe, if the pipe is elbowed towards a wall.
4. The cookstove must have its own chimney flue. Do not connect this unit to a chimney flue serving other appliances.
5. Connection of the cookstove to the chimney should be made as direct as possible (6 feet maximum horizontal) and no more than two bends should be used, as needed. Any reductions in the flue pipe should be no less than 6" in diameter. The pipe connecting the cookstove to the chimney should be at least 24 gauge. Thicker gauges are available, and will resist corrosion longer and need fewer replacements. Slope the flue pipe towards the cookstove 1/4" per foot of horizontal run, this will help any condensation that forms in the pipe to be carried back down into the cookstove. The cookstove connection pipe should be installed so that the upper pipe section fits inside the lower connection pipe section. This way any condensation building up inside the pipe, will stay inside the pipe as it flows down through the surface and back into the cookstove. Horizontal pipe runs should have the pipe seams turned up. Particular attention should be paid to the point where the flue passes through a wall or ceiling; This penetration should always be made with chimney thimble, insulated pipe, and proper accessories based on the manufacturer's instructions. Chimney connectors must not pass through the ceiling, through concealed spaces, or enter the chimney in the attic, unless proper clearance is attained or the insulated pipe is used based on the manufacturer's instructions.

**REMEMBER:** all pipe sections should be connected by at least 3 sheet-metal screws per joint. A fire in the stack may cause vibration, and poorly fastened piping may come apart, causing an extreme fire and smoke hazard. Do not extend the stove pipe past the inside edge of the flue liner. If you have a manufactured stainless steel chimney, attach the stove pipe to a stove pipe adapter. Whenever the pipe connects to a masonry chimney, the flue to the chimney should be larger than the stove pipe, ensuring that you can insert the pipe out to the inside edge of the chimney (not past). Be sure to seal as tight as possible and cover with a stove pipe collar.

**CAUTION:** do not store combustible or flammable materials near cookstove.

## COOKSTOVE LOCATION

	Specifications	420	520	
	Unit to left wall	18" / 457 MM	18" / 457 MM	
	Unit to back wall	18" / 457 MM	18" / 457 MM	
	Unit to back wall w/ heat shield	12" / 305 MM	12" / 305 MM	
	Unit to right wall	12" / 305 MM	12" / 305 MM	
	Front	48" / 1220 MM	48" / 1220 MM	
	Unit to ceiling	36" / 915 MM	36" / 915 MM	
	Chimney connection to wall	18" / 457 MM	18" / 457 MM	
	Corner Installation	10" / 254 MM	10" / 254 MM	

This cookstove must be installed with, and maintain, the clearances shown in the illustration above.

1. Set the cookstove on a solid, non-combustible floor.
2. Use a non-combustible floor board (Type 1 Board).
3. The hearth material must extend out at least 15" from the front edge, 8" from either side and 8" behind the cookstove. It also must run underneath and extend 2" beyond either side of the Exhaust Box and stove pipe, if the pipe is elbowed towards a wall.

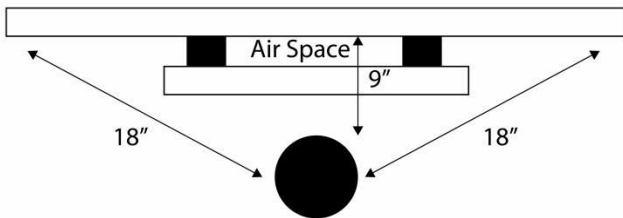

According to NFPA Standards, single-walled stove pipes can be within 9 inches of a combustible, provided an approved fire retardant material is utilized. It must also be covered with 28 gauge sheet metal and spaced out 1" on non-combustible spacers.

# CHIMNEY REQUIREMENTS

The minimum height of a chimney system for the Heco Cookstove is 20 feet. The chimney must extend above the roof of a house at a minimum of 3 feet at any exit points. On a pitched roof, installation of the chimney must be 2 feet higher than anything within a 10 foot radius of the chimney. It is important to have a chimney draft of 0.06 water column. It is required to abide by the manufacturer's instructions on Class A chimneys, as well as local building codes. It is not recommended to build a chimney on a building addition that is lower than the original part of the house. Do not extend the stovepipe past the inside of a masonry chimney liner and never connect this unit to a chimney serving another appliance.

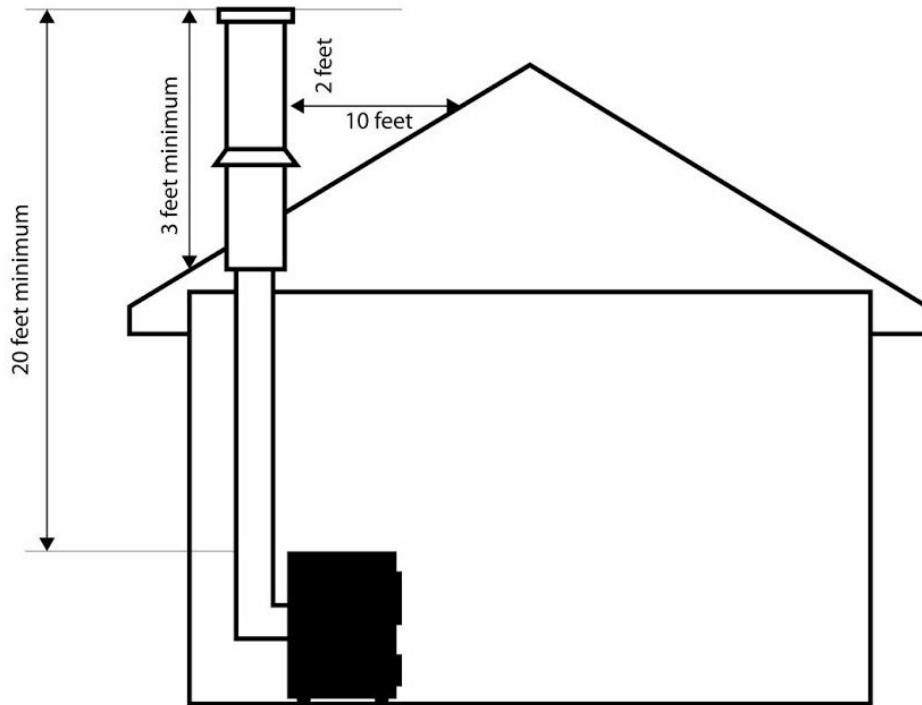

1. The cookstove must have its own chimney flue. One cookstove per flue.
2. The chimney must be a masonry (recommending Chimtek), or a stainless steel insulated chimney system.
3. The masonry chimney should not have any missing mortar or loose bricks.
4. No mortar or chimney parts should be blocking the chimney flue.
5. There should be a two inch clearance between any chimney; except a Chimtek Masonry Chimney System, which has 0 clearance.
6. The chimney should extend at least 2 feet above the highest point of the house, or 2 feet above the point at which the chimney is 10 feet from the roof.



# OPERATION CONTROLS

## Primary Air Control

This Bimetal Regulator is used to adjust the Primary Air. Primary Air is the main draft that enters into the stove, under the grates in the fire box, to add oxygen to the fire. This control is used less when burning wood, as wood needs 80% Secondary Air. It is not uncommon to use only Secondary Air when burning wood.

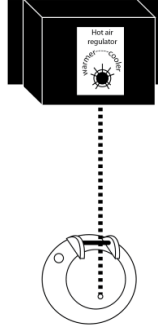

## Secondary Air & Airwash Control

The Secondary Air Control is on the left side of the stove and feeds the Secondary Air Reburn Tubes located at the top of the fire box, as well as the air wash located at the front of the fire box. The air wash works as the primary air when burning wood and keeps your fire door glass clean when open. When burning coal, set the secondary air at approximately 50%. **WARNING! DO NOT CLOSE SECONDARY AIR CONTROL WHEN BURNING COAL AS THIS COULD RESULT IN GAS EXPLOSIONS.** Pull the secondary air handle out to provide more air flow in the fire box and to keep your fire door glass clean. Push the secondary air handle in to decrease the air flow in the fire box.

## Wood Plate

The cookstove comes with a steel Wood Plate (installed), which must be used when burning wood. Always be sure to remove the steel Wood Plate when burning coal.

### Wood Plate

NOTE: Remove when burning coal

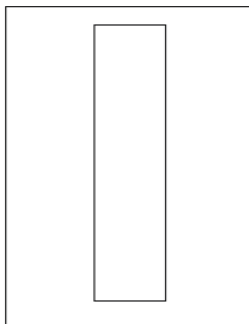

# BAKING & COOKING CONTROLS

The Heco Cookstove is designed for both oven baking and stovetop cooking. The Oven Bypass Control is used to set the stove in either Cook Mode or Bake Mode. This control is changed by using the handle located on the right side of the cookstove (see below). You can cook and bake at the same time while in Bake Mode, but cannot do this while in Cook Mode. Do not set the cookstove in Bake Mode if you are not baking, this will decrease the lifetime of your cookstove's oven box and require more frequent creosote clean out. The diagram below shows the two settings for the Oven Bypass Control; pull the handle (on the right side of the stove) out to set the cookstove in Bake Mode and push the handle in for Cook Mode.

**CAUTION:** Keep fire box door closed at all times while in Bake Mode. Opening the fire box door while in Bake Mode will cause smoke spillage!

## Oven Bypass Control

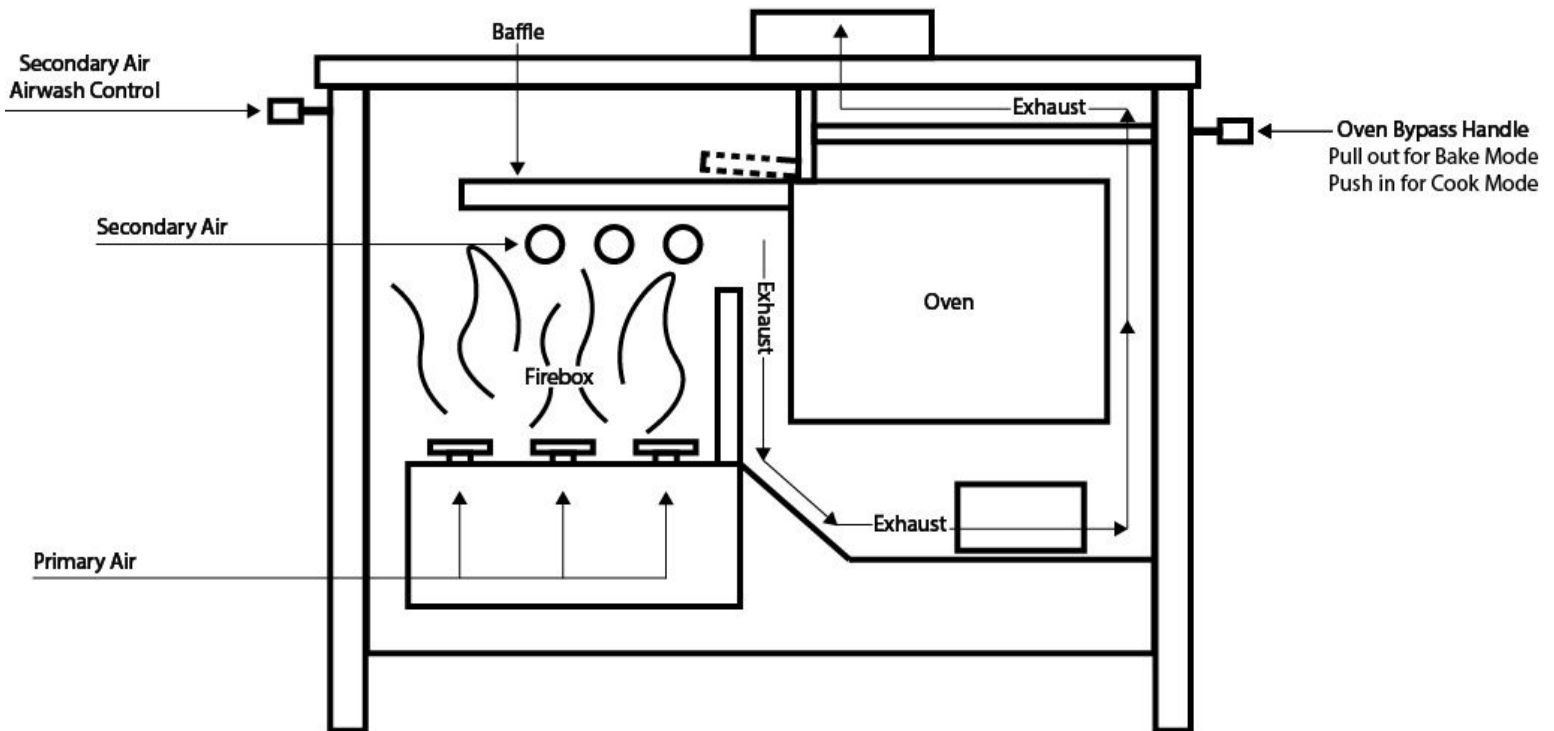

# DOMESTIC WATER OPTIONS

## 22 Gallon Reservoir

The 22 Gallon Water Reservoir is manually filled and not a pressurized system. The reservoir tank fits on the back of the cookstove and is fastened with a bolt. The water in the reservoir will naturally be heated through contact with the stove top. The water is dispensed through a faucet on the side. Keep the reservoir full of water at all times to avoid causing it to boil. Never allow the reservoir to sit completely empty as it will void the warranty. If you would like to use your cookstove to supply all of your hot water needs, see the reservoir coil kit option below. This coil kit heats the water faster, providing a larger volume of hot water for you to use.

## Reservoir Coil Kit Option

This Reservoir Coil Kit allows your 22 Gallon Water Reservoir to heat water faster and keep a consistent water temperature. This is only recommended for use with the 22 Gallon Water Reservoir, as the 12" coil used in the Coil Kit does not produce enough heat for an external tank. You will need this coil kit if you use the hot water in your 22 Gallon Water Reservoir frequently throughout the day.

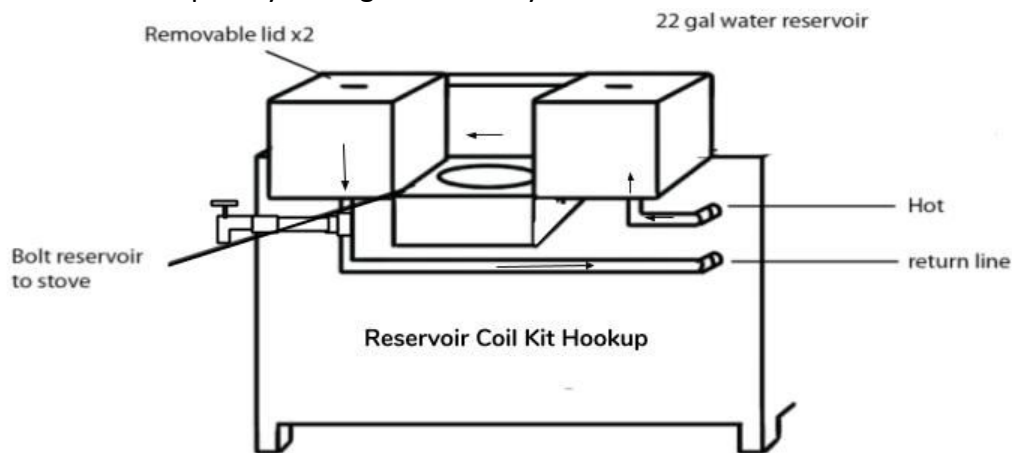

## External Tank Coil Option - 3/4" X 23" Coil (Part# HC6-34C)

This coil is designed to be used with an external tank that is separate from the cookstove. This tank should not be an existing water heater, but should be a holding tank that is separate from the existing gas or electric water heater that you currently have. This tank must be a minimum of 40 gallons, and **must have a 150# relief valve**. Do not install a check valve in your cold water supply. The installation of this coil should be done by a professionally trained plumber.

**Review manual included with External Tank Coil for installation instructions.**

**Note:** All Heco Cookstove models are built with the option of adding this External Tank Coil, allowing you to connect to an independent holding tank.

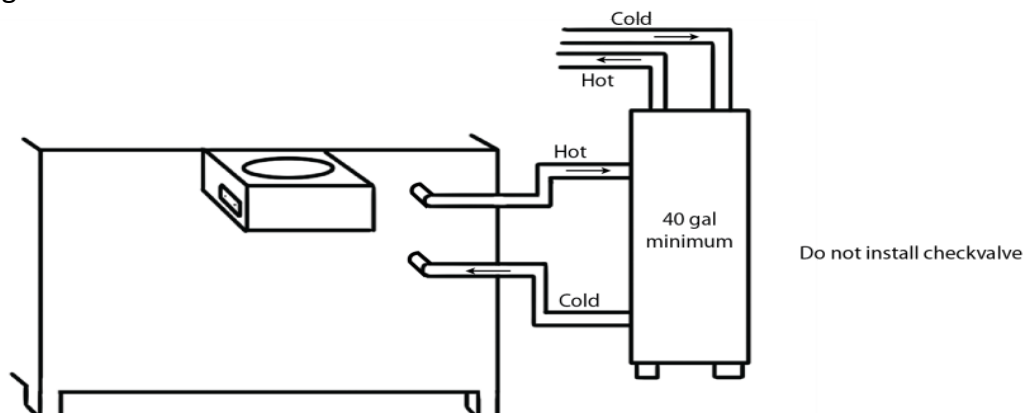

# EXHAUST CLEANOUT

## Underneath Bake Oven

Below the oven, on the front right side of the stove, is a clean-out door. This door is behind a porcelain panel. To remove the porcelain panel, lift up and pull. Inside you will find a plate fastened by two wing nuts, remove the wing nuts and plate. Use the small scraper (provided with the stove) to pull out any fly ash or debris that has accumulated (see drawing below).

## Beside Bake Oven

When facing the front, as you circle the stove counter-clockwise around to the back of the stove, there is a small door on a swivel. Open this swivel door and use your scraper to clean between the side of the bake oven and the cookstove frame (see drawing below).

## Exhaust Box

On the back of the stove, where the chimney pipe enters the stove, you will find the cookstove's Exhaust Box. This box is used for cleaning a straight horizontal chimney. On the right side of the exhaust box you will find a small plate that is held on by two wing nuts. Remove the wing nuts and plate and use your scraper to remove the ash in the Exhaust Box (see drawing below).

**NOTE:** Remember to close all plates after cleaning, if left open, they can affect the draft and result in smoke spillage.

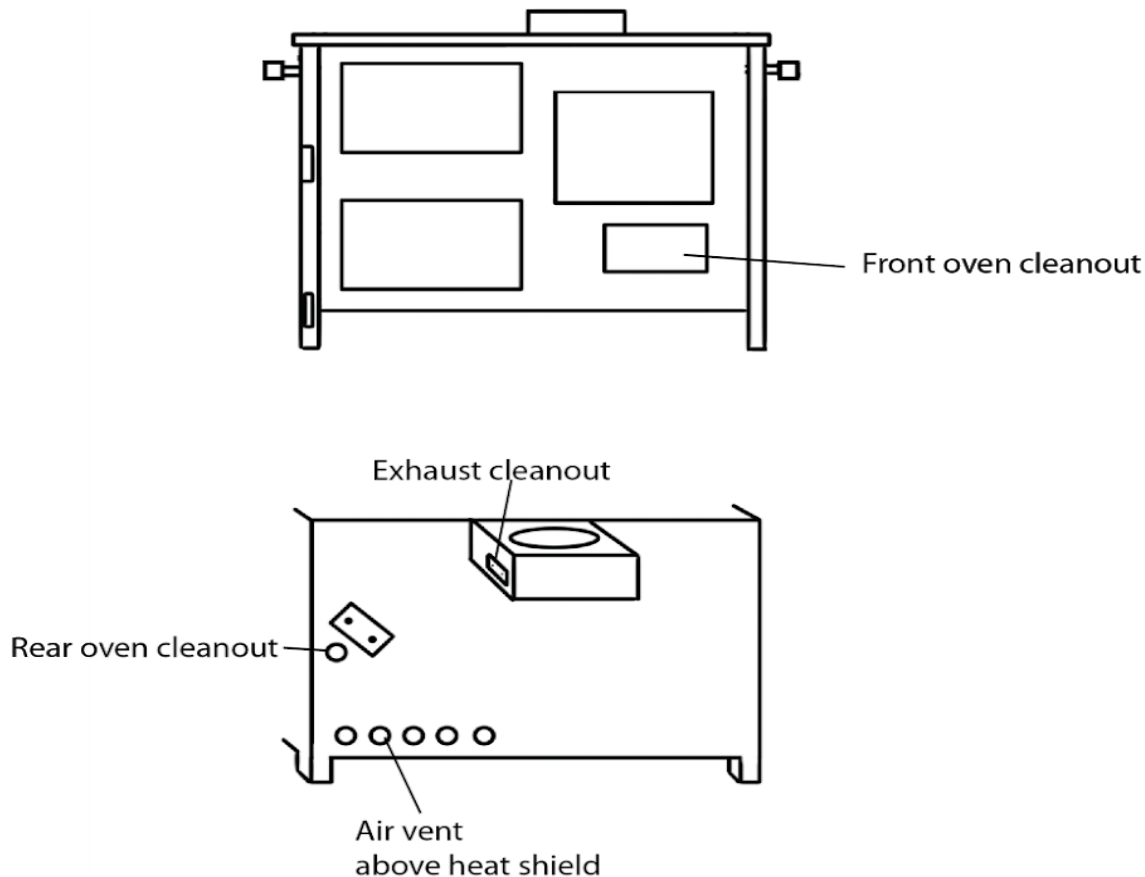

## 420 Parts List

Description	Part #
Glass Fire Door	420-1
Solid Fire Door	0420-1-1
Ash Door	420-5
Glass Oven Door	420-7
Solid Oven Door	0420-7-1
Replacement Oven (no porcelain parts)	420-14
Airwash Shuttle	420-18
Top Border	420-19
Front Right Leg	420-22
Front Left Leg	420-23
Back Left Leg	420-24
Back Right Leg	420-25
Shelf Side Panel (left or right)	420-31
Shelf Top	420-32
Front Top Grid	420-33
Stove Side Panel	420-34
Oven Bypass Holder/Angle	420-35
Shelf Back	420-36
Oven Top Insert	420-37
Rear Cleanout Cover	420-38
Removable Bypass Baffle	420-39-1
Front Left Filler Panel	420-40
Front Right Filler Panel	420-41
Center Cover Panel	420-42
Left Firebrick Angle	420-43
Rear Standard Heat Shield	420-45
Rear Exhaust Heat Shield	420-46
Ash Pan	420-47
Oven Glass Holder	420-48
Oven Door Heat Shield (No Glass)	420-50
Center or Right ¼" Cooktop (polished)	420-51
Center or Right ¼" Cooktop (porcelain)	420-51P
Left Side ¼" Cooktop (polished)	420-51L

Description	Part#
Left Side ¼" Cooktop (porcelain)	420-51LP
Left Top Firebox Heat Deflector	420-52
Oven Insert (left or right)	420-53
Front Oven Cleanout Door	420-55
Rear Exhaust Cleanout Door	420-56
Fire Door/Ashdoor Handle	420-57
Shelf Backsplash	420-61
Fire Door Glass Holder	420-62
Coil Cover Plate	420-64
C-Cast Baffle	420-90
Oven Insulation Shields (2 per stove)	420-91
Fire Door Glass	420-110
Oven Door Glass	420-111
Oven Door Gasket	GF011
Firedoor/Ash Door Gasket Replacement Kit	heco-GRK4/4-9
4" x 18 Cast Iron Grates	4X18-CIG
2 - Grate Rail (Front)	420-24-GRF
2 - Grate Rail (Back)	420-24-GRB
Cast Iron Louvers	CI-FL
Alum Draft Intake	ALUM-DA
Hot Air Reg w/23" Chain	HOT-A-REG-23
Oven Thermometer	50-550
Door Handle/Shaker (Wood Handle)	handle-B
Airwash/Oven Bypass (Wood Handle)	handle-D
Oven Handle (Wood Only)	handle-A
Oven Stainless Shelf	OR-17 5 18
Wood Plate	HC-WP
Right Top Firebrick C-Channel	420-120
Right Center Firebrick C-Channel	420-121
Oven Bypass Rod w/ Handle & Cotter Pin	420-122
Oven Bottom Insert	420-91
Oven Back Insert	420-92

# 420 Firebrick List

## Firebrick Panels for Heco 420 Cookstove

**Back Layout**

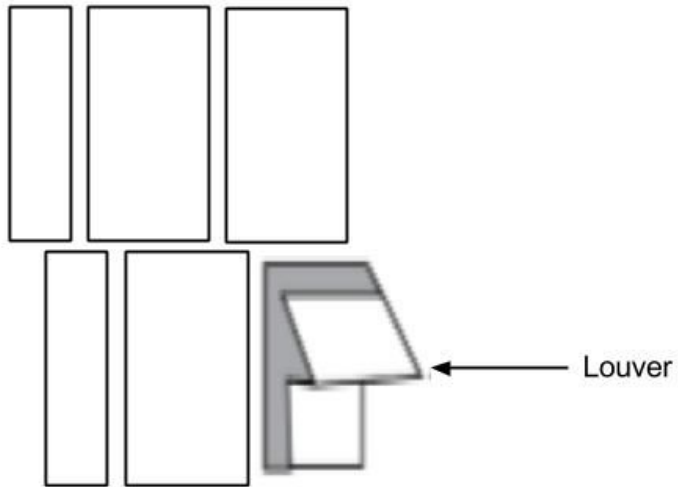

**Left Side Layout**

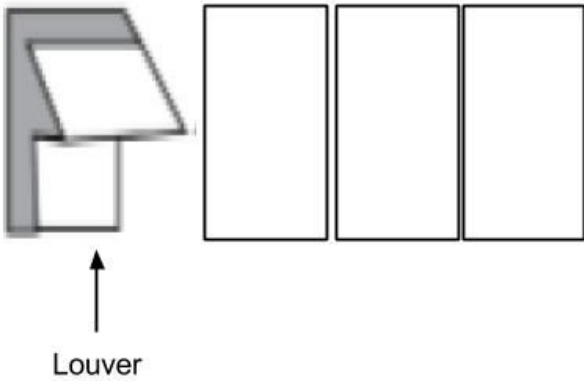

**Right Side Layout**

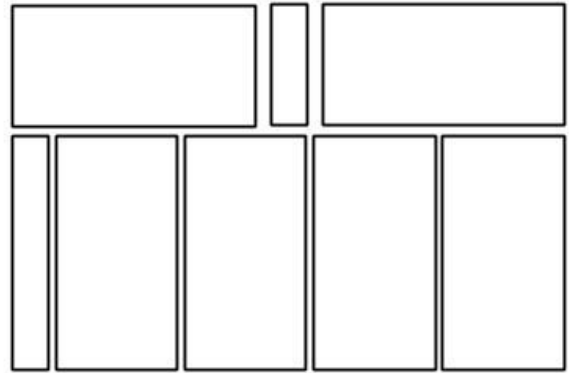

**Front Layout**



Left Side Bottom: (3) 1 ¼" x 4 ½" x 9"  
 Right Side Top: (2) 1 ¼" x 4 ½" x 9"  
 (1) 1 ¼" x 4 ½" x 1"  
 Right Side Bottom: (4) 1 ¼" x 4 ½" x 9"  
 (1) 1 ¼" x 1 ⅝" x 9"

Front: (3) 1 ¼" x 4 ½" x 5 ⅜"  
 (1) 1 ¼" x 3 ⅝" x 5 ⅜"  
 Back Top: (2) 1 ¼" x 4 ½" x 9"  
 (1) 1 ¼" x 2 ¾" x 9"  
 Back Bottom: (1) 1 ¼" x 4 ½" x 9"  
 (1) 1 ¼" x 2 ¾" x 9"

## 520 Parts List

Description	Part #
Glass Fire Door	520-1
Solid Fire Door	0520-1-1
Ash Door	520-5
Glass Oven Door	420-7
Solid Oven Door	0420-7-1
Replacement Oven (no porcelain parts)	420-14
Airwash Shuttle	420-18
Top Border	520-19
Front Right Leg	420-22
Front Left Leg	420-23
Back Left Leg	420-24
Back Right Leg	420-25
Shelf Side Panel (left or right)	420-31
Shelf Top	520-32
Front Top Grid	520-33
Stove Side Panel	420-34
Oven Bypass Holder/Angle	420-35
Shelf Back	520-36
Oven Top Insert	420-37
Rear Cleanout Cover	420-38
Removable Bypass Baffle	420-39-1
Front Left Filler Panel	520-40
Front Right Filler Panel	420-41
Center Cover Panel	420-42
Left Firebrick Angle	420-43
Rear Standard Heat Shield	520-45
*Rear Exhaust Heat Shield	420-46
Ash Pan	520-47
Oven Glass Holder	420-48
Oven Door Heat Shield (no glass)	420-50
Center or Right ¼" Cooktop (polished)	420-51
Center or Right ¼" Cooktop (porcelain)	520-51P
Left Side ¼" Cooktop (polished)	520-51L

Description	Part #
Left Side ¼" Cooktop (porcelain)	520-51LP
Left Top Firebox Heat Deflector	520-52
Oven Insert (left or right)	420-53
Front Oven Cleanout Door	420-55
Rear Exhaust Cleanout Door	420-56
Fire Door/Ash Door Handle	420-57
Shelf Backsplash	520-61
Fire Door Glass Holder	520-62
Coil Cover Plate	420-64
C-Cast Baffle	420-90
Oven Insulation Shields (2 per stove)	420-91
Fire Door Glass	520-110
Oven Door Glass	520-111
Oven Door Gasket	GF011
Fire Door/Ash Door Gasket Replacement Kit	heco-GRK3/4-9
4" x 18" Cast Iron Grates	4X18-CIG
3 - Grate Rail (front)	520-24-GRF
3 - Grate Rail (back)	520-24-GRB
Cast Iron Louvers (2 per stove)	CI-FL
Aluminum Draft Intake	ALUM-DA
Hot Air Regulator w/23" Chain	HOT-A-REG-23
Oven Thermometer	50-550
Door Handle/Shaker (Wood Handle Only)	handle-B
Airwash/Oven Bypass (Wood Handle Only)	handle-D
Oven Handle (Wood Handle Only)	handle-A
Oven Stainless Steel Shelf	OR-17 5 18
Wood Plate	HC-WP
Right Top Firebrick C-Channel	420-120
Right Center Firebrick C-Channel	420-121
Oven Bypass Rod w/Wood Handle & Cotter Pin	420-122
Oven Bottom Insert	420-91
Oven Back Insert	420-92

# 520 Firebrick List

## Firebrick Panels for Heco coostove 520

**Back Layout**

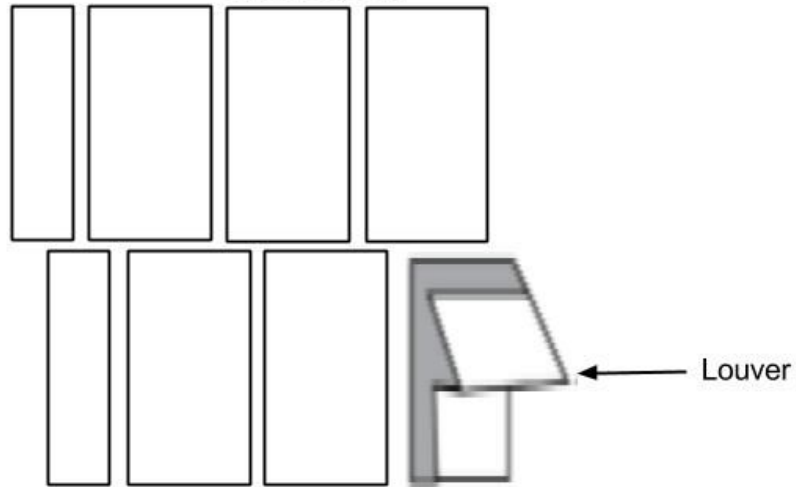

**Left Side Layout**

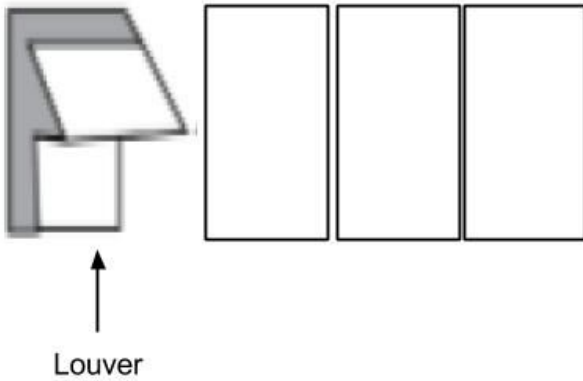

**Right Side Layout**

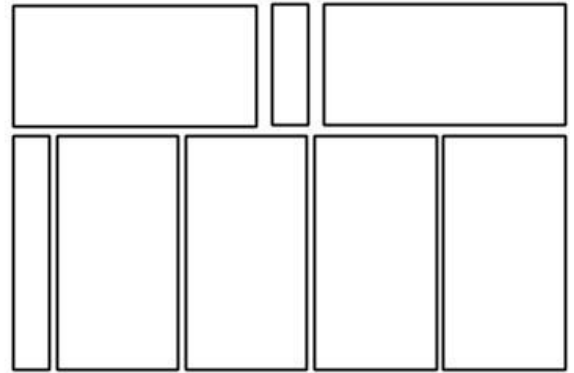

**Front Layout**



Left Side Bottom: (3) 1 ¼" x 4 ½" x 9"  
 Side Top: (2) 1 ¼" x 4 ½" x 9"  
 (1) 1 ¼" x 4 ½" x 1"  
 Right Side Bottom: (4) 1 ¼" x 4 ½" x 9"  
 (1) 1 ¼" x 1 ⅝" x 9"

Front: (3) 1 ¼" x 4 ½" x 5 ⅜"  
 (1) 1 ¼" x 3 ⅝" x 5 ⅜"  
 Back Top: (3) 1 ¼" x 4 ½" x 9"  
 (1) 1 ¼" x 2 ¾" x 9"  
 Back Bottom: (2) 1 ¼" x 4 ½" x 9"  
 (1) 1 ¼" x 2 ¾" x 9"

Right



# TROUBLESHOOTING

Symptom	Problem	Cause	Solution
Difficulty lighting or maintaining fire, excessive smoking or back-puffing	-Inadequate draft -Wet wood	-Cold chimney -Closing oven bypass before chimney is heated -Obstruction inside chimney -Chimney is too short -Oversized chimney liner: 420 Stove is designed for 6" and 520 is designed for 7" -Negative pressure in house (caused by furnace, exhaust fans, dryer etc.) -Too much ash in firebox	-Only operate 1 stove per chimney -Wood must have 20% or less moisture -Keep damper open until fire is established -Inspect & clean chimney and stove pipe -Remove obstruction -Extend chimney -Install liner (flue liner should have the same diameter as the flue collar of the stove) -Turn off cookstove and other exhaust factors when stove is burning -Crack a window to allow air into the room -Increase chimney height to increase draft -When burning coal, shake out ashes every 12 hours. When burning wood, ashes should not cover louver vents
Smoking or back-puffing when cook plate or fire door is open	-Temporarily inadequate draft to pull smoke up chimney	-Oven damper is closed -Cold chimney -High winds -Poor quality wood	-Open damper prior to opening the door -Allow more time to warm up; Wait until the wind dies down and install high wind cap -Check stove for cracks -Check all cleanout doors to ensure they're closed, including chimney cleanout.
Fire is difficult to control	-Excessive draft	-Too much draw on chimney -Door/glass gaskets loose or deteriorated -Ash pan door is not closed -Excess air coming into stove	-Install stovepipe damper in stove pipe -Adjust door hinges to tighten the door seal -Replace the gasket if deteriorated
Wood is hard to light, just sizzles and steams	-Wet/Damp wood	-Inadequate seasoning - Wood should be split - Moisture getting into stored wood	-Allow wood to dry under cover for one year after splitting -Keep split wood covered (sides open) -Install liner to match stove flue size -Close oven damper
Oven won't heat adequately	-Inadequate draft -Low firebox temp -Heat not reaching oven	-Oversized chimney or liner too large -Oven damper could be open -Wet wood	-Allow wood to dry under cover for a minimum of one year after splitting -Keep split wood covered (sides open) -Install liner to match stove flue size -Close oven damper -Use 2"-4" split firewood to increase btu's
Inaccurate temperature readings	-Door thermometer not accurate	-Door thermometer does not always provide 100% accurate readings	-Use interior oven thermometer

## TROUBLESHOOTING

Symptom	Problem	Cause	Solution
Food is cooking unevenly	-Inconsistent oven temperatures	-Fire not stabilized -Oven bypass is open, sending heat to the top of the oven and out the chimney -Location of oven rack -Dirty stove	-Allow fire to stabilize (4-5" of red hot coals) -Recharge fuel as needed -Adjust oven racks -Rotate food for more even results -Cleanout around bakeoven using the recommended cleanout access doors
Slow Cooking	-Cooking surface not hot enough	-Fire not hot enough -Oven damper closed -Inadequate contact between cooking vessel and cooktop -Wet wood -Chunks of wood are too large to create flame	-Add fuel and/or increase draft -Move cooking vessel to the left side of cooktop -Use flat bottomed cooking vessels -Use wood pieces split to 2"-4" and below 20% moisture content
Stove rusting	-Wet or old conditions	-Condensation from temperature fluctuations -High humidity areas -Unheated structure	-Prep stove for storage with food based grease -Run dehumidifier -Run heat on low when cookstove is not in use
Campfire Smell	-Negative pressure	-Reverse flow in chimney -Moisture & creosote combination	-Remove negative pressure in home by cracking a window or adding a fresh air inlet -Only operate 1 stove per chimney -Clean stove -Check all cleanout doors to ensure they're closed, including chimney cleanout
Burn Time is not long enough when burning wood	-Burning too much wood	-Wet wood -Soft wood -Wood too dry -Not enough ash buildup -Burning kindling -Burning too hot	-Use seasoned hardwood (split, stacked and under cover for 1 + year) -Allow 4 - 6" of ash buildup on grates -Burn at normal burn -Use larger pieces of firewood, smaller pieces will burn faster and hotter -When burning coal, add larger amounts (30 lbs plus per loading)

## **Heco Cookstove Limited Lifetime Warranty**

**COVERAGE.** Breeo, LLC warrants to the original purchaser that all Heco products are free from workmanship and material defects during the lifetime of the original purchaser. If a product is defective, Breeo, LLC, at its option, will repair or replace with a new product free of charge, excluding any applicable shipping and handling charges. No warranty is offered on rust, paint or finishes due to being made with material with potential for corrosion. Altering any Breeo product, or using the product in any way other than the intended use, will void this Lifetime Warranty. Ropes, gaskets, paint, porcelain coatings, firebricks, baffles, wood handles, glass, ash pans, and hot water heating components (coils & reservoirs) will not be covered under this warranty. These fall under normal maintenance. Damage due to incorrect installation and failure to comply with local authorities or follow correct protocol is also excluded. No warranty is offered on rust, paint or finishes due to being made with material with potential for corrosion. Damages caused due to missing fire brick in the fire box will not be covered under this warranty.

**REPLACEMENT.** The customer must arrange to deliver or ship the stove/part to an authorized Heco dealer at their expense and arrange for pickup or delivery of the same after the repairs have been made. If, upon inspection, any damage is found to be the fault of the manufacturer, the repair or replacement will be made. This warranty does not include expenses incurred from travel time or loss of service. This warranty is not transferable and is extended only to, and is solely for the benefit of, the original retail purchaser of the stove. Please keep your dated sales receipt as proof of purchase.

**NOTICE.** This warranty is void if installation or service is performed by someone other than a qualified installer or service agency, or if installation is not in conformity with installation instructions or local fire and building regulations. All warranty claims must be submitted through the authorized Heco dealer from whom the product was originally purchased.

The stove top should not exceed 800 degrees. All warranty will be void if surfaces reach above 800 degrees. You can purchase a stove top thermometer to aid in monitoring your temperature.

This warranty does not cover damage or product failure caused by accident, misuse, negligence, tampering, overloading, improper attachment, or improper maintenance. Breeo, LLC is held harmless for any injury or death caused by the misuse of this product.

This warranty gives you specific legal rights providing said product is put to its proper designated use.

**EXCLUSIONS.** THIS WARRANTY IS EXPRESSLY IN LIEU OF ALL OTHER WARRANTIES, EXPRESS OR IMPLIED, INCLUDING THE WARRANTY OF MERCHANTABILITY AND FITNESS FOR A PARTICULAR PURPOSE. NO ORAL AGREEMENT, GUARANTEE, PROMISE, REPRESENTATION OR WARRANTY SHALL BE BINDING. IN NO EVENT WILL BREEO, LLC BE LIABLE FOR ANY SPECIAL, INDIRECT, INCIDENTAL OR CONSEQUENTIAL DAMAGES EVEN IF BREEO, LLC HAS BEEN ADVISED OF THE POSSIBILITY OF SUCH DAMAGES AND EVEN IF BREEO, LLC HAS KNOWLEDGE THAT FAILURE TO PERFORM COULD CAUSE CONSEQUENTIAL ECONOMIC LOSSES. IN ANY EVENT, CUMULATIVE DAMAGES FOR BREACH OF THIS WARRANTY WILL BE LIMITED TO THE AMOUNT ACTUALLY PAID TO BREEO, LLC FOR THE PRODUCT. THIS PARAGRAPH SHALL APPLY TO ALL ACTIONS RELATED TO THE PRODUCT, WHETHER BASED ON TORT, CONTRACT OR OTHER THEORIES. THE PURCHASER ACKNOWLEDGES THAT THIS PARAGRAPH ALLOCATES THE RISK OF PRODUCT FAILURE BETWEEN BREEO, LLC AND THE PURCHASER, AND THAT THIS ALLOCATION IS REFLECTED IN THE PRICE PAID.

**Manufactured by:**



5002 Lincoln Hwy. East  
Kinzers, PA 17535  
1-800-413-9848  
info@breeollc.com