

HI300 Medium Wood Insert

Model	HI300
Optimum Efficiency	77%
Emissions (grams/hr) EPA Certified	3.8 grams/hr
Maximum BTU*	75,000 BTU
Maximum Log Size	18"
Firebox Size	2.3 cu. ft.
Flue Size	6"
Burn Time (typical)*	up to 8 hrs.

* Length of burn time and BTU Range depends on type of wood, climate conditions and installation.



Unit With Cast Faceplate

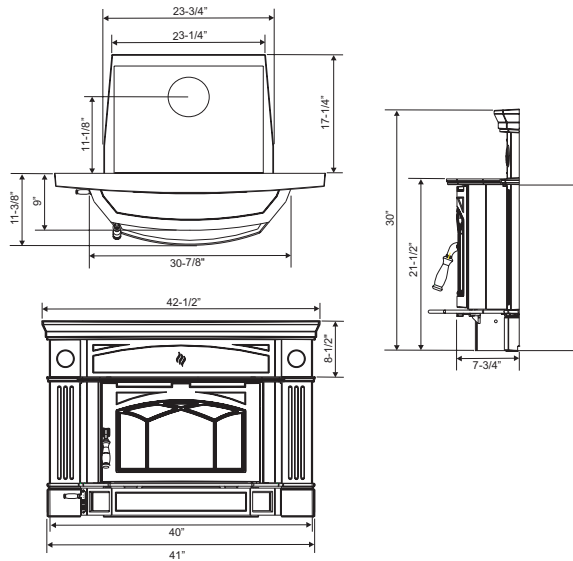

Unit With Oversize Cast Faceplate

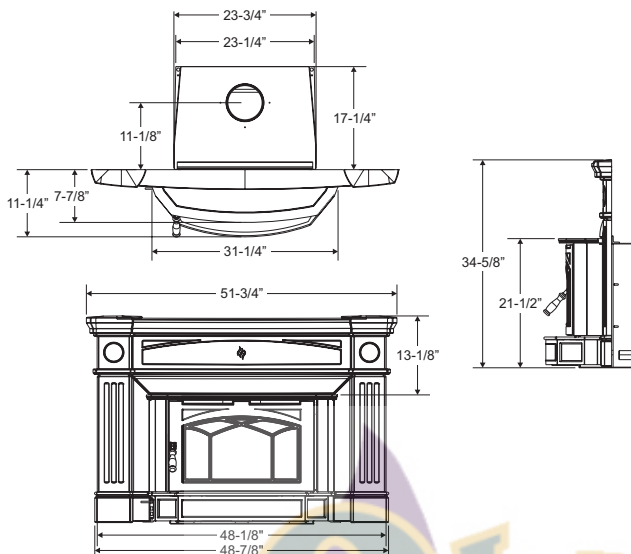

Minimum Fireplace Opening	
Height	21-1/2" (546mm)
Width	25" (635mm)
Depth	17-1/2" (445mm)

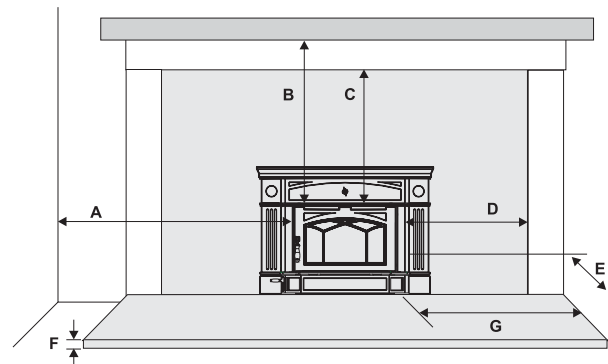

Dimension	Description	I2400
A	Adjacent Side Wall (to side)	11" (280mm)
B	Mantle (to top)**	20" (508mm)
	Mantle Depth (not shown) Maximum	10" (254mm)
C	Top Facing (to top)	12" (305mm)
D	Side Facing (to side)	8" (205mm)
E	Minimum Hearth Extension*	18" (455mm)
F	Minimum Hearth Thickness*	0.5" (13mm)
G	Minimum Hearth Side Extension	8" (205mm)

Side and Top facing is a maximum of 1.5" thick.

Floor protection must be non-combustible, insulating material with an R value of 1.1 or greater.

* **Hearth thickness of 0.5" with k value = 0.84", R value = 6 or greater.**

** **A non-combustible mantel may be installed at a lower height if the framing is made of metal studs covered with a non-combustible board.**

Thermal floor protection is not required if the unit is raised 3.5" minimum (measured from the bottom of the stove). However, standard ember floor protection is required. It will need to be a non-combustible material that covers 16" (406 mm) in the US and 18" (450 mm) in Canada to the front of the unit and 8" (200 mm) to the sides.

If the unit is not raised, thermal floor protection required is 18" (450 mm) in the US and Canada.

All floor protection must be non-combustible (i.e., metals, brick, stone, mineral fiber boards, etc.) Any organic materials (i.e. plastics, wood paper products, etc.) are combustible and must not be used. The floor protection specified includes some form of thermal designation such as R-value (thermal resistance) or k-factor (thermal conductivity).