

H200 Cast Freestanding Woodstove

Model	H200
Optimum Efficiency	74%
Emissions (grams/hr) EPA Certified	3.9 grams/hr
Maximum BTU*	38,800 BTU
Maximum Log Size	16"
Firebox Size	1.34 cu. ft.
Flue Size	6"
Burn Time (typical)*	up to 6 hrs.

* Length of burn time and BTU Range depends on type of wood, climate conditions and installation.

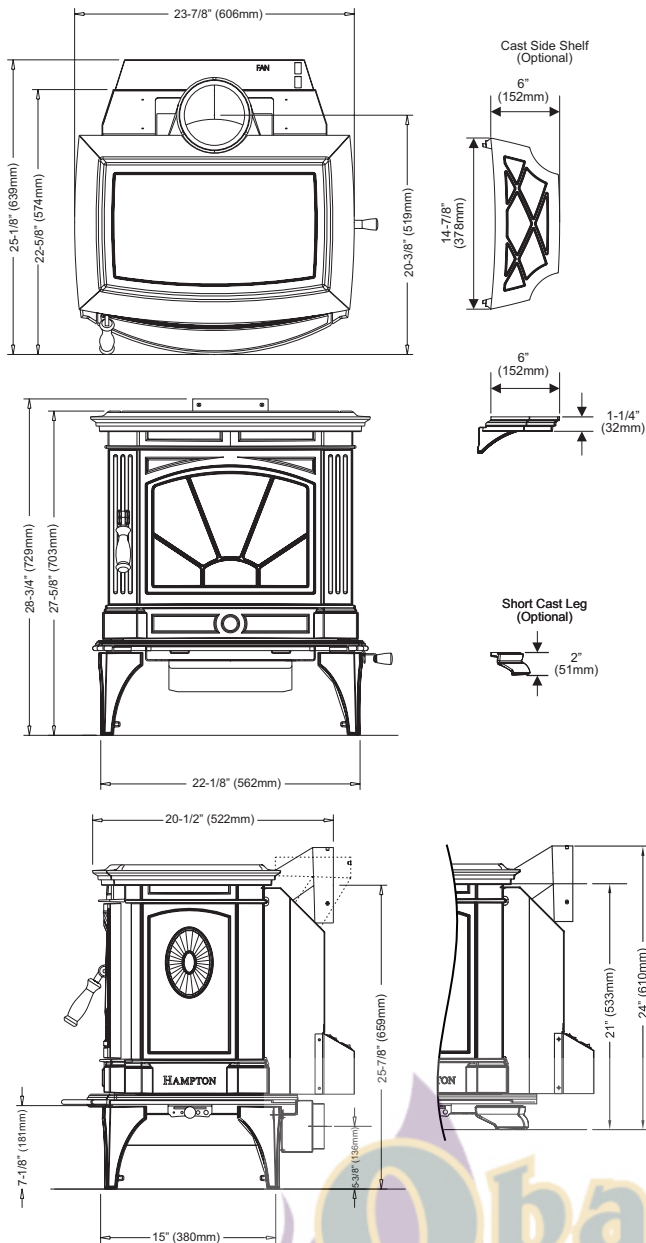

Minimum Clearance To Combustible Materials

Please read the section below carefully as clearances depend on whether the airmate or the rear heat deflector is installed on the stove.

Measurements "From Unit" are from the top plate of the stove to a side wall or to a corner, and from the rear heat shield to a back wall.

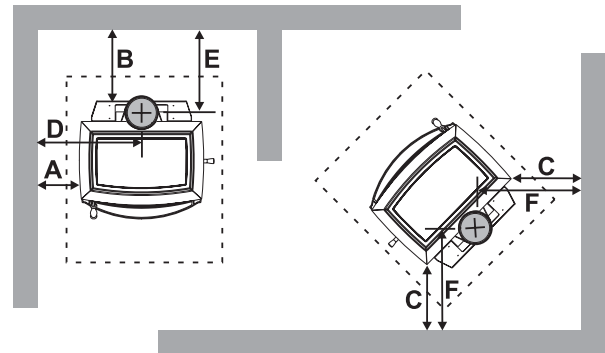

Residential Installation "C" Vent (Single Wall)						
Unit (with heat Shield)	From Unit		From Corner	From Vent centerline		
	A	B	C	D	E	F
H200	17"	15"	13"	29"	17-1/8"	19-7/8"

Residential Close Clearance (To be installed with required pipe components)						
When the stove is installed as a close clearance residential unit, a listed double wall connector is required from the stove collar to the ceiling level.						
Unit (with heat Shield)	From Unit		From Corner	From Vent centerline		
	A	B	C	D	E	F
H200	15"	10"	9"	27"	12-1/8"	15-7/8"



Wood Stoves

H200 Wood Stove

Mobile Home Close Clearance (To be installed with required pipe components)
 *C" Vent single wall pipe is not approved for Mobile Home installations. (Refer to mobile home instructions.)

Unit (with heat Shield)	From Unit		From Corner		From Vent centerline	
	A	B	C	D	E	F
H200	15"	10"	9"	27"	12-1/8"	15-7/8"

Minimum Alcove Clearance To Combustible Materials

Hampton Freestanding models have been alcove approved and must be installed with a listed double wall connector to the ceiling level.

Note: Minimum alcove ceiling height - 60"
Maximum depth of alcove - 48"

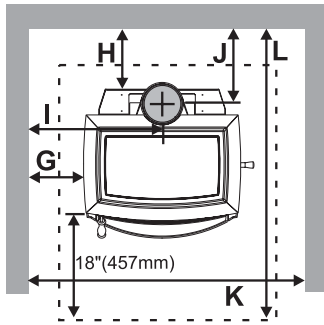

Unit (with heat Shield)	From Unit		From Vent centerline		Min. Width	Min. Hearth to Rear Wall
	G	H	I	J		
H200	15"	13"	27"	15-1/8"	54"	50"

Additional Clearances For Backwall Exit

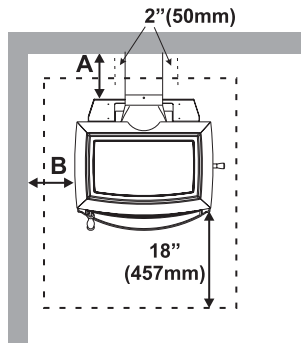

Unit (with heat Shield)	Minimum Clearances:				
	To Combustibles		To Non-Combustibles		
	A	B	A	B	
H200	9"	15"	0-9"	15"	
Min. Mantel Height (from finished floor):		48"			
Max. Mantel Depth:		12"			

Note: Floor protection must extend 2" to each side of the elbow.

Floor Protection

A combustible floor must be protected by a non-combustible material (like tile, concrete board, or certified to UL-1618 or as defined by local codes) extending beneath the heater and a minimum of 6" from each side and minimum 18" from the front face of the stove and minimum 6" (or the rear clearance to combustibles whichever is smaller) from the rear of the stove.

When installed with horizontal venting, non-combustible floor protection must be installed underneath the flue pipe and extend 2" (51mm) beyond each side.

Minimum Overall Width (X) of Floor Protector for all installations:

H200 (US)	36"
H200 (Canada)	40"

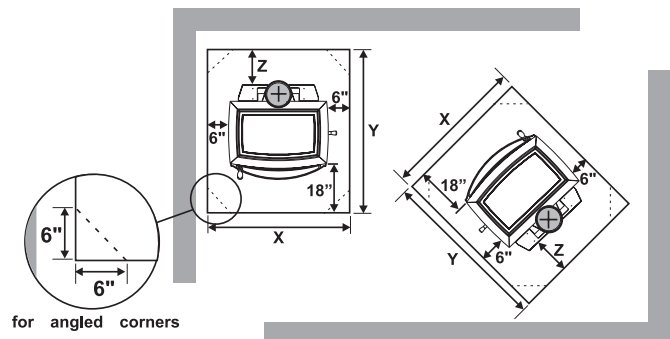

NOTE: In Canada, floor protection must extend 18" to the front and 8" to each side of the stove.

Minimum Overall Depth (Y) of Floor Protector

Unit	Residential "C" Vent		Residential Close Clearance		Mobile Home Close Clearance		Alcove	
	Y	Z	Y	Z	Y	Z	Y	Z
	H200 (US)	43"	6"	43"	6"	43"	6"	43"
H200 (Canada)	45"	8"	45"	8"	45"	8"	45"	8"

*The rear clearance to combustibles is less than 6" (152mm), for corner installations the rear corners may be angled to take advantage of the closer clearances.