

ESSE

Bakeheart and Warmheart

Wood Fired Cook Stove
Owner's Manual

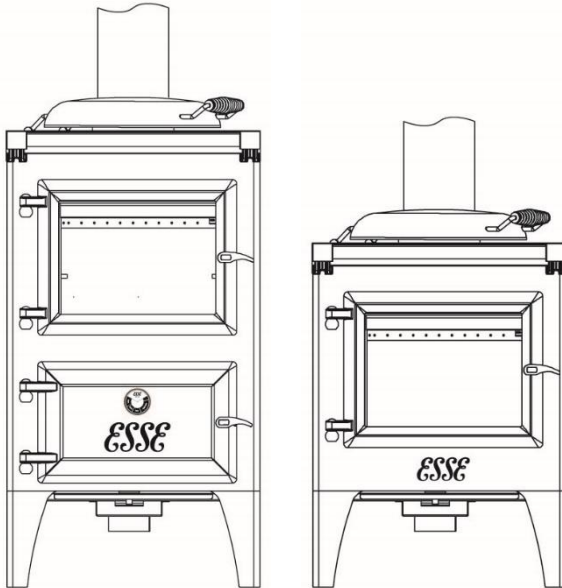









**MADE IN
BRITAIN** 



OMNI-Test
Laboratories, Inc.
0224WS009S
0224WS009E

GENERAL SAFETY

All ESSE cook stoves are designed and manufactured to be simple and efficient to use, and we've taken great care to ensure that they meet the applicable safety requirements, when appropriately installed and used. Before use, ensure you are familiar with the following:

	PLEASE READ THIS ENTIRE MANUAL BEFORE YOU INSTALL AND USE YOUR NEW ROOM HEATER. FAILURE TO FOLLOW INSTRUCTIONS MAY RESULT IN PROPERTY DAMAGE, BODILY INJURY, OR EVEN DEATH.
	THIS COOK STOVE HAS A MANUFACTURER-SET MINIMUM LOW BURN RATE THAT MUST NOT BE ALTERED. IT IS AGAINST FEDERAL REGULATIONS TO ALTER THIS SETTING OR OTHERWISE OPERATE THIS WOOD HEATER IN A MANNER INCONSISTENT WITH THE OPERATING INSTRUCTIONS IN THIS MANUAL.
	DO NOT INSTALL THIS APPLIANCE WITHIN A MOBILE HOME.
	DO NOT CONNECT THE UNIT TO A CHIMNEY FLUE SERVING ANOTHER APPLIANCE.
	DO NOT CONNECT TO OR USE IN CONJUNCTION WITH ANY AIR DISTRIBUTION DUCTWORK UNLESS SPECIFICALLY APPROVED FOR SUCH INSTALLATIONS.
	CONTACT LOCAL BUILDING OR FIRE OFFICIALS ABOUT RESTRICTIONS AND INSTALLATION INSPECTION REQUIREMENTS IN YOUR AREA AND THE NEED TO OBTAIN A PERMIT.
	WHEN THIS ROOM HEATER IS NOT PROPERLY INSTALLED, A HOUSE FIRE MAY RESULT. TO REDUCE THE RISK OF FIRE, FOLLOW THE INSTALLATION INSTRUCTIONS. CONTACT LOCAL BUILDING OR FIRE OFFICIALS ABOUT RESTRICTIONS AND INSTALLATION INSPECTION REQUIREMENTS IN YOUR AREA.
	THIS ROOM HEATER MUST BE CONNECTED TO: <ul style="list-style-type: none">• A CHIMNEY COMPLYING WITH THE REQUIREMENTS FOR TYPE HT CHIMNEYS IN THE STANDARD FOR CHIMNEYS, FACTORY-BUILT, RESIDENTIAL TYPE AND BUILDING HEATING APPLIANCE, UL 103, OR...• A CODE-APPROVED MASONRY CHIMNEY WITH A FLUE LINER.
	THIS HEATER HAS BEEN CERTIFIED UNDER THE 2020 U.S. ENVIRONMENTAL PROTECTION AGENCY'S CORD WOOD EMISSIONS LIMITS FOR WOOD HEATERS.
	DO NOT USE A GRATE OR OTHER DEVICE TO ELEVATE THE FIRE OFF THE FIREBOX FLOOR. BURN THE FIRE DIRECTLY ONTO THE BRICKS.
	NEVER USE GASOLINE, GASOLINE-TYPE LANTERN FUEL, KEROSENE, CHARCOAL LIGHTER FLUID, OR SIMILAR LIQUIDS OR CHEMICALS TO START OR 'FRESHEN UP' A FIRE IN THIS HEATER. KEEP ALL SUCH LIQUIDS WELL AWAY FROM THE HEATER WHILE IT IS IN USE.
	HOT WHILE IN OPERATION. KEEP CHILDREN, CLOTHING AND FURNITURE AWAY. CONTACT MAY CAUSE SKIN BURNS.
	SAVE THESE INSTRUCTIONS FOR FUTURE USE.

This manual describes the installation and operation of the ESSE Bakeheart / Warmheart wood heater and cook stove. Under specific test conditions this heater has been shown to deliver heat at rates ranging from 10,001 – 46,685 Btu/hr. This appliance has been tested to ASTM 2515 and ASTM 3053 for Emissions, and UL 1482-2015 and ULC S627-00 for Safety.

Model name: ESSE Warmheart / ESSE Bakeheart

Manufacturer: ESSE Engineering Ltd., Long Ing, Barnoldswick, Lancashire, BB18 6BJ, UK

Contents

1. WELCOME TO YOUR ESSE	5
BEFORE USING YOUR COOK STOVE	6
2. OPERATING INSTRUCTIONS	6
GETTING TO KNOW YOUR COOK STOVE	6
SUPPLIED TOOLS AND PARTS.....	8
CO AND SMOKE ALARM.....	9
VENTILATION	9
FUEL.....	9
THE HEATSHIELD.....	9
WOOD LOGS.....	10
AIR SUPPLY	10
LIFTING THE BOLSTER LID.....	11
LIGHTING YOUR ESSE COOK STOVE	11
REFUELLING.....	13
EMPTYING THE FIREBOX OF EXCESS ASH.....	13
COOKING ON YOUR COOK STOVE.....	14
REDUCED BURNING.....	17
FLUE DRAFT	17
CLEANING & MAINTENANCE	17
REPLACING THE FIRE BRICKS	20
REPLACING THE FIRE GLASS.....	22
CHIMNEY SWEEPING	23
SAFE SHUTDOWN	23
SEASONAL USE.....	23
WARRANTY.....	24
TROUBLESHOOTING	25
PLANNING THE INSTALLATION	26
3. INSTALLATION INSTRUCTIONS	26
VENTILATION	26
INSTALLING THE HEATSHIELD.....	27
CO AND SMOKE ALARM.....	29
UNPACKING THE APPLIANCE	29

CHIMNEY & FLUE	29
CHIMNEY HEIGHT.....	34
POSITIONING WITHIN A MASONRY FIREPLACE.....	35
FLOOR PROTECTION	36
WALL CLEARANCES (CLEARANCE DISTANCES)	36
FLUE DRAFT.....	37
COMMISSIONING.....	37
4. CONSUMABLE PARTS	39

1. WELCOME TO YOUR ESSE

Welcome to the ESSE family. We've poured all of our knowledge, expertise and passion for designing and manufacturing market leading stoves, dating back to 1854, into producing your ESSE cook stove. All ESSE cook stoves are manufactured at our UK factory in Lancashire, UK, and we're confident that if appropriately installed, maintained and cared for, your ESSE cook stove will provide you with many years of room heating, cooking, comfort and joy.

Before you fire up your ESSE cook stove for the first time, ensure that your installer has installed the stove in line with the 'Installation' section of this manual, and that the flue and chimney has been swept. The cook stove is not suitable for use in a shared flue.

As you would expect, when in use, all parts of the stove become hot, so always use the supplied operating tool or glove when interacting with your ESSE cook stove. The cook stove is suitable for intermittent operation. Do not use an aerosol spray close to the stove when alight.

These instructions provide all the necessary information to both install, then operate your ESSE cook stove. The key information relating to your stove, including the serial number, can be found on the data plate, located at the rear of the cook stove. Please quote the model and serial number, in any future communication with your retailer or the manufacturer.

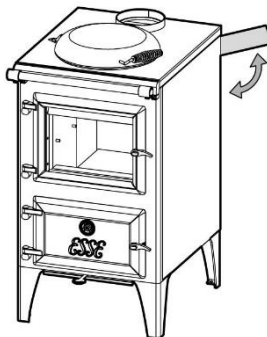

Data plate location

2. OPERATING INSTRUCTIONS

BEFORE USING YOUR COOK STOVE

Ensure that all protective packaging has been removed. The hotplate has been oiled at the factory to prevent rusting and therefore will require wiping with a damp cloth and drying with a paper towel, before use.

This appliance is suitable for burning wood only. An extractor should not be fitted within the same room as the appliance.



Do not place tea towels or similar items on the handrail.

GETTING TO KNOW YOUR COOK STOVE

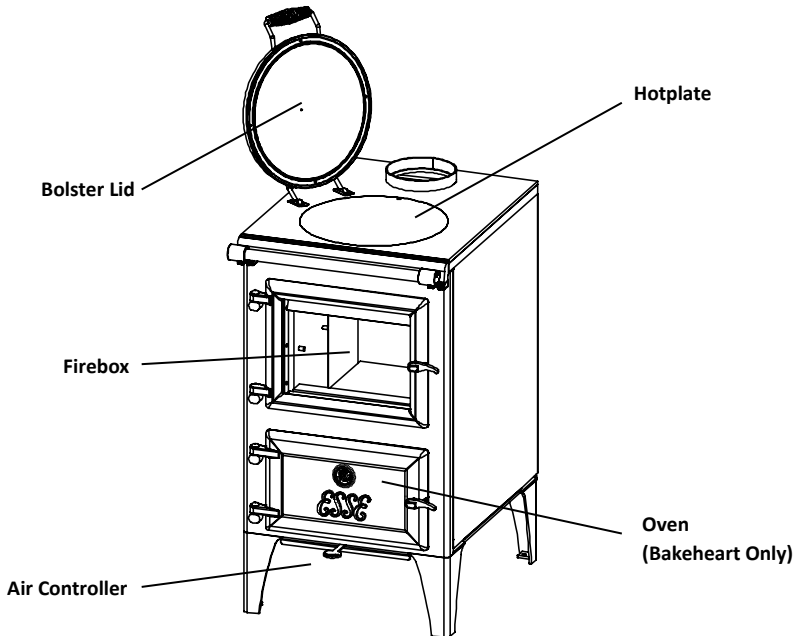

Air Controller

This is used to control the fire intensity, by managing the amount of air supplied to the fire. When moved to the right, there is more air and a fiercer burn rate, whilst moved to the left, there is less air, and softer burn rate.

2. OPERATING INSTRUCTIONS

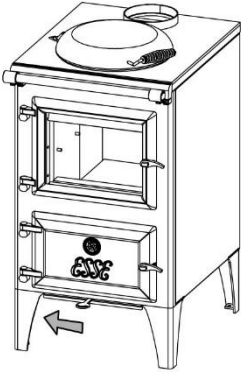

Move left, to reduce intensity

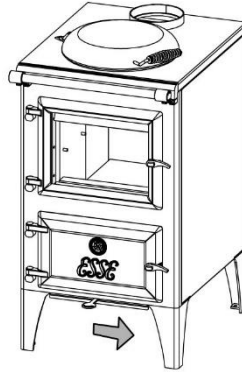

Move right, to increase intensity

The firebox is accessed through the large glass fronted fire door, which is opened by rotating the catch 90° counter-clockwise. On the Bakeheart model, the oven is behind the bottom door, which is also opened by rotating the catch 90° counter-clockwise. Please note, when in use, both of these catches will become hot, so always use the supplied operating tool or glove to open and close them. The operating tool or glove should also be used to adjust the Air Controller.

If the cook stove is being used primarily to heat the room, we recommend leaving the bolster lids open, allowing heat from the hotplate to radiate into the room.

2. OPERATING INSTRUCTIONS

SUPPLIED TOOLS AND PARTS

Your ESSE cook stove comes supplied with...

		BH	WH
Heatshield	• To install on the rear wall	✓	✓
Glove	• For interacting with the controls	✓	✓
Operating Tool	• Hotplate removal & opening doors	✓	✓
Wire Brush	• For cleaning ovens & hotplate	✓	✓
Firebox Shelf	• For cooking direct onto embers	✓	✓
Oven Shelf	• For cooking within the oven	✓	✓
Fireshield	• To direct heat away, whilst cooking	✓	X

Please keep all of these items in a safe place.

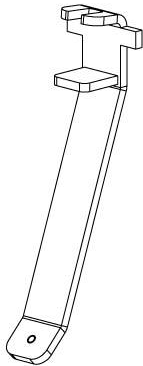

Operating Tool (I-WH-100-004US)

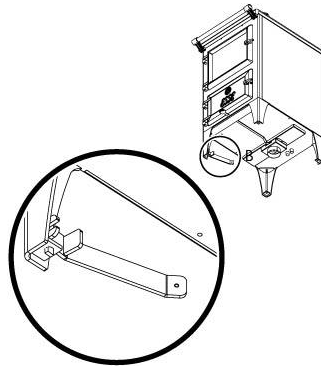

Operating Tool storage



This appliance is not appropriate for use as an incinerator, and unsuitable fuels should not be used. Failure to follow this requirement will invalidate your warranty.

2. OPERATING INSTRUCTIONS

CO AND SMOKE ALARM

Your installer should have ensured that you have a carbon monoxide (CO) and smoke alarm fitted, in the same room as your ESSE cook stove. You should make sure that you are familiar with the operation of these essential pieces of equipment.

VENTILATION

All stoves require a consistent supply of 'combustion air', to allow for the combustion of the fire. Your installer should have ensured that there is appropriate air source to your ESSE cook stove. For more information, see the 'Ventilation' section within the Installation part of this manual.

FUEL

Your ESSE stove has been designed to burn wood logs, of appropriate quality and moisture content.

Approved fuels

- ✓ Wood logs

Unapproved fuels

- X Wet wood
- X Overly dry wood
- X Treated timber
- X Smokeless mineral fuel
- X Petroleum based fuels
- X Bituminous house coal
- X Printed paper and cardboard



This appliance is not appropriate for use as an incinerator, and unsuitable fuels should not be used. Failure to follow this requirement will invalidate your warranty.

THE HEATSHIELD

Your cook stove comes supplied with a heatshield. This heatshield must be installed if the vertical substrate behind the cook stove is of combustible

2. OPERATING INSTRUCTIONS

material. See the 'INSTALLING THE HEATSHIELD' section in the 'Installation instructions' section of this document for more information.

WOOD LOGS

Burning wood logs within your ESSE cook stove provides sustainable, efficient and 'clean' heating to your room. The moisture content of your wood is very important, as this affects both how 'cleanly' your stove will burn, and also how long the fuel will burn for. Referred to as 'green wood', recently felled wood will almost certainly have a moisture content that is too high to burn efficiently and cleanly. Similarly, overly dry wood will burn quickly, with higher emissions, making your stove less economical to run.

We recommend using wood logs with a moisture content of 15 – 20%. This is best achieved by either storing green wood yourself for a period of 12 – 18 months, and checking regularly with a moisture detector, or purchasing it from a reputable fire wood specialist, who is able to control the moisture content of their wood logs.

Your wood should be stacked safely, so as to not allow absorption of moisture from rain, condensation or flooding. If stacked outdoors, ensure your wood is not stacked directly onto the ground.

Do not store wood in the space between your cook stove and adjacent surfaces, which provides the required distance to combustibles, or in areas which may become hot over time, causing a fire risk, eg, under the cook stove.

AIR SUPPLY

ESSE cook stoves are designed to achieve the most efficient heat outputs, with the 'cleanest burn'. To achieve this, significant research and development investment has been given to how to provide appropriate levels of 'combustion air' to the correct parts of the fire, at the correct time of the burn cycle.

Combustion air is drawn into your ESSE stove from four locations, one of which is controllable. It is important to understand the function of each, and where appropriate, how they are controlled.

2. OPERATING INSTRUCTIONS

Controllable Combustion Air Controllable Combustion Air enters your ESSE cook stove from the circular air inlet at the base of the appliance, and is adjusted by the air controller. When moved to the right, there is more air and a fiercer burn rate, whilst moved to the left, there is less air, and softer burn rate.

Tertiary Air Tertiary Air enters your ESSE cook stove through two small air inlets the base of the appliance, entering the firebox through a series of holes in two pipes located at the top of the firebox. The amount of Tertiary Air is not adjustable, but carefully positioned to help achieve improved efficiency and a clean burn.

Pilot Air Pilot Air enters your ESSE cook stove through a small hole at the front of the base of the appliance. The Pilot Air helps keep the cook stove burning cleanly, even towards the end of a log's useful life.

LIFTING THE BOLSTER LID

The bolster lid should be lifted using the supplied Operating Tool.

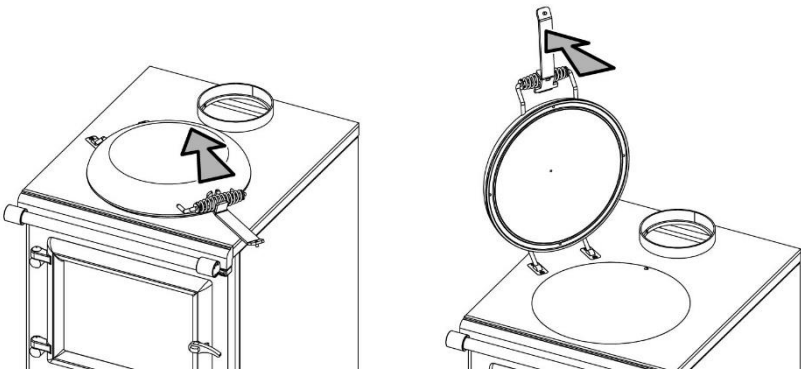

1. Position the Operating Tool under the Bolster Lid handle.

2. Carefully pull the Bolster Lid upwards, until it holds in an open position.

LIGHTING YOUR ESSE COOK STOVE

2. OPERATING INSTRUCTIONS

When your ESSE cook stove is first lit, it may smoke, give off an odour, or make ‘ticking noises’. This is quite normal, as the materials used within its manufacture are heated up for the first time. These symptoms will stop within a short period, but ensure that the room is well ventilated during this ‘settling in’ process.

The pallet that your ESSE cook stove was supplied on has been produced from timber that is appropriate for use as kindling, so can be broken up and chopped, for this purpose.

Initially only light a small fire, for a period of 1 – 2 hours, to dry out any moisture found within the flue and chimney.



Whilst lighting the fire, do not leave your ESSE cook stove unattended, until the fire is established, the door is fully closed, and you have adjusted the Air Controller to the appropriate level.



Before lighting your ESSE cook stove, ensure that the Air Controller is fully open (Pushed to the right).

Lay two small wood logs along the length of the firebox base, and place a firelighter / tightly rolled up newspaper on top of them. On top, use wood kindling to create a small lattice structure.

Safely light the firelighter / newspaper and close the door, but leaving it slightly ajar. Once the flames have established on the wood logs, (typically within 3 – 5 minutes), place a small wood log on top and fully close the door. Slowly reduce the air volume, by moving the Air Controller to the left. Continue to use the Air

2. OPERATING INSTRUCTIONS

Controller to control the fire, until the flames are slowly 'dancing' on top of the wood logs.

It is very important that your ESSE cook stove is not overfired, as this may cause long term damage to the appliance, and invalidate your warranty.



The door should only be opened during the initial lighting / refuelling of your ESSE cook stove. If left open during normal operation, you may experience excessive smoke emitting into your room.



When the fire is lit within the cook stove, all controls and handles become hot - The operating tool or glove provided should be used when interacting with the appliance.



Take care not to strike the glass in the fire door, or slam the door shut, which may result in damage.

REFUELLING

Refuelling should be undertaken whilst the flames on the current fuel are still established, or you may experience excessive smoking. If the current fire has died out, reignite the fire with additional kindling, before adding additional fuel. When positioning fuel into the firebed, ensure that the fuel is not touching the back or side walls, or the glass window, as this will result in a less clean burn.

To enjoy optimum wood burning, leave an ashbed of ½" – 1" of ash within the base of the firebox. First rake the current fuel, to create a bed of hot embers, on which to place the new fuel. Then place the new wood logs onto the hot embers.



Do not 'overload' the fire with excessive amounts of fuel, as this will result in over-firing, and may cause permanent damage to your ESSE cook stove.

EMPTYING THE FIREBOX OF EXCESS ASH



Your ESSE cook stove will be hot during and after use. Always use the supplied Operating Tool and / or Stove Glove to riddle the appliance.

2. OPERATING INSTRUCTIONS



Never attempt to remove excess ash whilst the cook stove or ash is still hot.

Once the level of ash has built up greater than $\frac{1}{2}$ " – 1", excess ash should be removed from the base of the firebox using a metal shovel and disposed of safely.

Ash should be placed in a metal container with a tight fitting lid. The closed container of ashes should be placed on a non-combustible floor or on the ground, well away from all combustible materials, pending final disposal.

COOKING ON YOUR COOK STOVE

The ESSE Bakeheart both heats local spaces, whilst also being perfect for cooking on the hotplate, in the oven or even directly to the hot embers.

The ESSE Warmheart is primarily a local space heater, but also incorporates a handy hotplate, for cooking or keeping hot beverages, soups or stews warm.

The Oven (Bakeheart only)

When in use, the oven is heated through heat transfer from the fire, providing all round heat for perfect cooking. As a result, pans and casserole dishes can be placed on the bottom surface of the oven, without frying food, ensuring that all of the near 32lt of capacity is useable space.

The oven is deeper than it is wide, to reduce heat loss when the door is opened for inspection of the food, helping to maintain a cooking temperature. The oven door should be kept closed when in use.

Always use the supplied Glove or Operating Tool to open the oven door, as the handle gets hot when in use. To open the oven door, turn the handle 90° counter-clockwise, and carefully swing open.

A temperature gauge is located within the oven door, which can be used to give a guide to the temperature within the oven. Remember that when the door has been opened, the temperature shown

2. OPERATING INSTRUCTIONS

on the dial will drop, and take time to correct when the door is subsequently closed. Please note, the temperature gauge should only be used as a guide to the oven temperature.

Your ESSE Bakeheart comes supplied with a wire shelf, which can be placed on the steel runner pins in the oven. The wire shelf has a retaining device, to reduce the risk of them pulling free of the cooker accidentally. To remove the shelf, pull forward as far as they come, then lift the front of the shelf up at an angle, and slowly pull free from the shelf runners.

The Hotplate

The design and position of the hotplate is carefully considered to give graduated areas of heat. The centre of the hotplate is positioned directly above the firebox, so will be the hottest area, and is perfect for boiling, whilst the outer areas are ideal for simmering.

To maintain hotplate cooking temperatures, the Bolster Lid should be closed when the hotplate is not in use.

The Firebox (Bakeheart only)

To fully enjoy the unique flavours of wood fired cooking, your ESSE Bakeheart allows for cooking directly over wood embers, providing classic chargrill lines on the supplied wire shelf.

The Firebox Cooking Shelf can be positioned into the firebox after lighting. Once the fire has died down to glowing embers, using the supplied Glove, carefully slide the Firebox Cooking Shelf into position along the steel pin runners, located on the side bricks.



The fire door should always be closed, whilst cooking in the firebox.

2. OPERATING INSTRUCTIONS

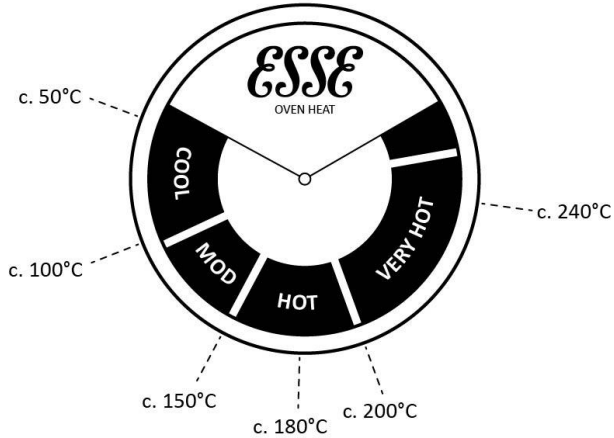

The Oven Gauge, with temperature guide

Remember that the oven gauge (Bakeheart only) is a useful tool for giving an indication of the oven temperature, but due to how the oven is heated, should not be relied upon to give an exact temperature reading.

When the hotplate is not in use, the bolster lids should be left down, to help retain heat and keep the hotplates warm.

Once up to temperature, relatively small amounts of fuel are required to keep the cooking areas hot. With this in mind, resist the temptation to add excessive amounts of fuel to the firebox, which can cause long-term damage to your ESSE cook stove, whilst also making the appliance uncomfortably hot to stand in front of, during cooking. If this does become a problem, the supplied Fireshield (Bakeheart only) can be placed in front of the glass oven door, to help deflect heat away from the user.

To install the Fireshield, simply hang it onto the hand rail in front of the glass firedoor.

2. OPERATING INSTRUCTIONS

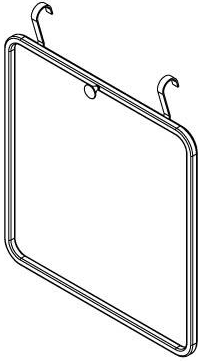

Fireshield (Bakeheart only)

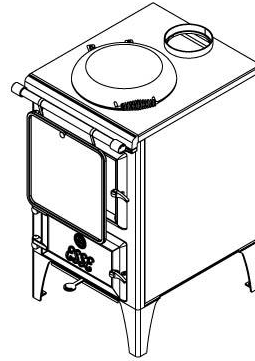

Fireshield in use (Bakeheart only)

REDUCED BURNING

Once a fire has established, close down the air control, and ensure that the door is firmly closed. Experimentation with the setting of air controls may be required, depending upon the flue draft and fuel type. A build-up of soot on the inside face of the glass window is more likely when operating the cook stove in this way.

FLUE DRAFT

An appropriate flue draft is essential for the stove to work safely and efficiently. During installation, your installer should have taken a flue draft reading, to ensure that it is within the recommended range of 12 – 25 Pascals. If your cook stove is burning wood logs quickly, or adjusting the Air Controller is having little effect on controlling the fire, consult with your installer to confirm the flue draft remains appropriate.

CLEANING & MAINTENANCE



This wood heater needs periodic inspection and repair for proper operation. Consult the owner's manual for further information. It is against federal regulations to operate this wood heater in a manner inconsistent with the operating instructions in the owner's manual.

2. OPERATING INSTRUCTIONS

Your ESSE cook stove should be inspected frequently, and any required maintenance undertaken. We recommend that your ESSE cook stove is serviced once a year by a qualified service professional.

As the cook stove top is used for cooking, associated wear and tear will occur. Spills should be wiped up immediately with a damp cloth. Chemical oven cleaners should not be used on the hob surface.

The supplied wire brush can be used to remove stubborn stains from the hotplate, or inside the ovens.

Creosote – Formation and Need for Removal When wood is burned slowly, it produces tar and other organic vapors, which combine with expelled moisture to form creosote. The creosote vapors condense in the relatively cool chimney flue of a slow-burning fire. As a result, creosote residue accumulates on the flue lining. When ignited this creosote makes an extremely hot fire. The chimney connector and chimney should be inspected at least once every two months during the heating season to determine if a creosote build-up has occurred. If creosote has accumulated it should be removed to reduce the risk of a chimney fire.



Be aware that using the wire brush on the painted surfaces, (including the top that surrounds the hotplate), will cause damage to the paint finish.

The inside of the ovens can be given a coating of flax oil, which will help protect them against rusting, particularly when they oven is not in use for prolonged periods.



Repairs or modifications should only be undertaken by ESSE authorised professionals. Only genuine ESSE replacement parts should be used, or your warranty may become invalid.

General cleaning The exterior cast iron and sheet steel parts should be cleaned with a soft brush or lint-free cloth. Should areas

2. OPERATING INSTRUCTIONS

of the appliance need re-painting, high temperature aerosol paints are available from your retailer.

Glass window

Do not clean the glass whilst it is hot. If the glass window needs cleaning, use a damp cloth. If stubborn stains remains, use a dedicated glass cleaning solution. Do not use abrasive cleaners or pads, as these can scratch the surface, which may cause the glass to fail prematurely. Before relighting the appliance ensure that the glass has fully dried.

Rope seals

Ensuring a firm seal between the body of the appliance and the closed door is essential for the efficient and clean burning of your ESSE cook stove. The rope seals on the inside face of the door should be inspected regularly, and replaced as necessary.

Chrome parts

Chrome parts can be cleaned using a dedicated chrome cleaner. Do not use aggressive chemical cleaners, as these can dull the finish. Do not use aggressive scouring pads or brushes, as this can scratch the surface.

Exterior painted surfaces

The exterior of the cook stove is painted in a specialist high temperature wet paint, designed for this application. However, through the life of the cook stove, it may be necessary to touch up areas of paintwork. High temperature cook stove paints are available from your retailer.

Ensure that the cook stove is completely cool before undertaking any maintenance work. First remove any areas of flaky paint by gently rubbing with a wire brush. Then remove any areas of grease or oil, which will prevent the new layer of paint from adhering to the metal surface. Ensure other areas of the cook stove, and neighbouring items are masked off before applying the high temperature paint. If using an aerosol, ensure there is appropriate ventilation, and use appropriate personal protective equipment. Follow the manufacturer's instructions for application and use.

2. OPERATING INSTRUCTIONS

Internal flue ways

The flue ways inside the cook stove should be cleaned as part of the annual service, and at the same time as the flue and chimney are swept.

To do so, remove the hotplate by first inserting the end of the Operating Tool into the hole at the side of the steel disk. Then simply lever the hotplate up and clear of the appliance.

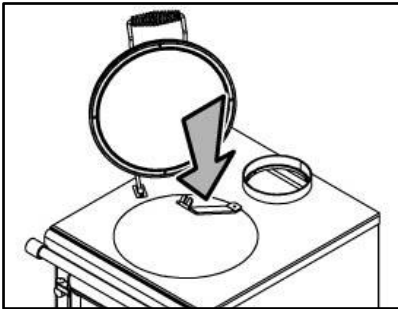

Hotplate removal

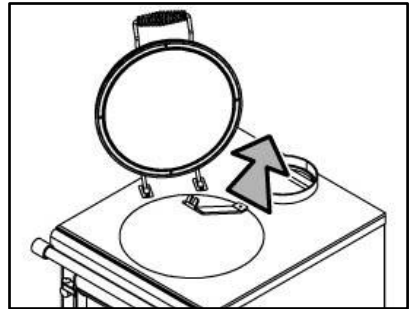

REPLACING THE FIRE BRICKS

During the life of your cook stove, the vermiculite firebricks will need replacing. The part numbers are shown in the 'Consumable Parts' section of this document. The bottom and rear bricks can be replaced through the front opening, whilst the side bricks and steel baffle require removal of the side panel.



Always wear gloves when undertaking any maintenance on your cook stove.

To replace the bottom and rear firebricks...

1. Lever up the base brick from the rear, using a flat head screwdriver.
2. Lever forward the rear brick from the top, using a flat head screwdriver.

To replace the side firebricks and steel baffle...

2. OPERATING INSTRUCTIONS

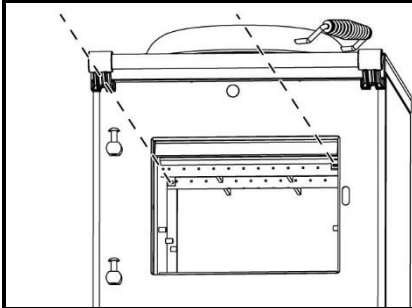

1. Remove the two screws holding the steel baffle in place.

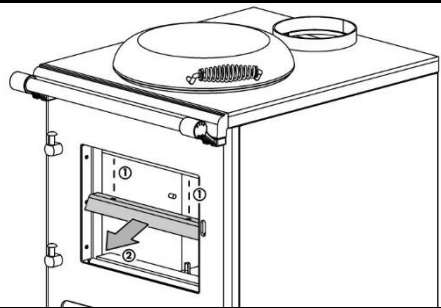

2. Remove the steel airwash by unscrewing the two screws holding it in place, and pulling clear through the front of the cook stove.

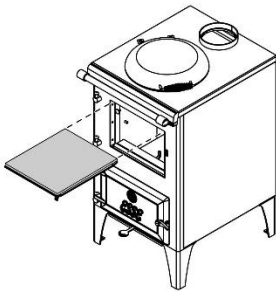

3. Remove the steel baffle and baffle insulation, through the front of the cook stove.

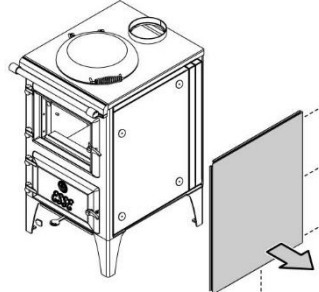

4. Remove the side panel, by unscrewing the three screws at the rear of the cook stove, and the screw at the bottom of the panel.

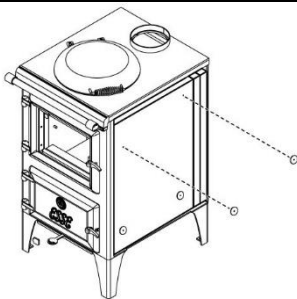

5. Remove the top two disks holding the insulation in place, (do not remove the bottom two disks).

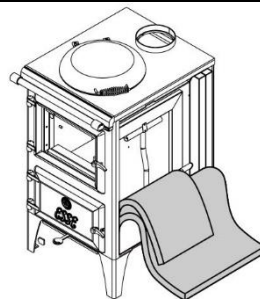

6. Peel down the two layers of insulation, to reveal the air pipes.

2. OPERATING INSTRUCTIONS

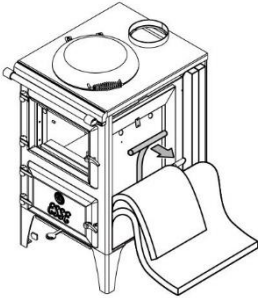

7. Slacken the fixing bolt holding the horizontal air pipe bracket in place, and swing it clear.

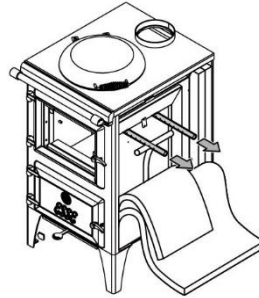

8. Pull the two air pipes clear from the firebox.

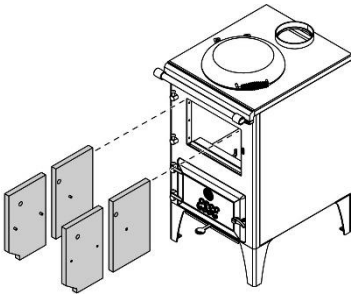

9. Remove the four side fire bricks through the front of the cook stove, insert the replacement bricks, then reverse steps 1 – 8.

REPLACING THE FIRE GLASS

During the life of your cook stove, the fire door glass may need replacing. Do not use the appliance if there is any sign of damage to the glass. Care should be taken when replacing the fire door glass. Only use 4mm ceramic glass, appropriate for use in wood fired stoves. The replacement glass should be $12^{53/64}$ " x $9^{29/64}$ " (326 x 240mm). If the original glass is damaged, take extra care, using appropriate hand and eye protection, and dispose of the broken glass appropriately.

To replace the glass...

2. OPERATING INSTRUCTIONS

1. Open the fire door.
2. Slacken off the two bottom glass retaining clips.
3. Remove the top two glass retaining clips.
4. Remove the used glass panel and ladder tape (15mm x 3mm thin rope) which sits around the glass panel.
5. Run a new length of ladder tape around the new panel of glass.
6. Insert the glass and ladder tape into position on the bottom two glass retaining clips.
7. Swing the glass up into position, and loosely fix into place with the two top retaining clips.
8. Tuck the rope behind the four retaining clips, and tighten all four up, ensuring the glass is firmly held in place.

CHIMNEY SWEEPING

To ensure continued safe and efficient use of your ESSE cook stove, we recommend that your chimney is swept by a professional at least once a year, typically before the stove season. Where the appliance is used throughout the year, we recommend more regular sweeping.

SAFE SHUTDOWN

In the unlikely event of a chimney fire, a fault occurring with the appliance, or extreme weather affecting the burn of the appliance, move the Air Controller to the left, closing down the combustion air supply to the minimum volume. This will minimise the intensity of the flames in the appliance, which will then slowly die out. In the case of a fire in the chimney or flue, immediately call the Fire Department for assistance.

SEASONAL USE

If your ESSE cook stove is to not be used for a period of time, first clean the appliance as described within the 'Cleaning & Maintenance' section of this manual. Empty the firebox of all ash, before closing the door. Position the Air Controller to a central position – This will allow a flow of air, preventing a build-up of moisture inside your ESSE cook stove, which can lead to rusting. Before re-

2. OPERATING INSTRUCTIONS

lighting the appliance, remove the top baffle bricks, to remove any debris, and check for blockages within the flue.

WARRANTY

Your ESSE cook stove has been built to the highest standard using premium materials, and comes with a two year manufacturer's warranty. Register your ESSE cook stove, by either completing or returning the supplied Warranty Registration Card, or by registering online at www.esse.com/warranty-registration, and receive a warranty upgrade to five years. The warranty must be registered within 1 month of installation to qualify for the 5 year warranty.

The conditions of your warranty are...

- ✘ Does not cover incorrect use or application, as advised within this manual.
- ✘ Must be installed appropriately, by a certified installer.
- ✘ Does not cover consumable parts, including glass window, rope door seals and vermiculite fire bricks.
- ✘ Does not cover general wear and tear or cosmetic damage unrelated to the function of the appliance.

In the first instance, please contact your North American ESSE dealer, for warranty or service matters.

2. OPERATING INSTRUCTIONS

TROUBLESHOOTING

Problem	Cause	Solution
Window glass blackening	• Wet wood logs	• Use wood logs with 15-20% moisture content
	• Fuel touching glass window	• Use a poker to move fuel back within the fire box
	• Too little combustion air	• Increase the setting of the air controller
Fumes emit into room	• Blocked flue	• Check and remove any blockage
	• Downdraft in flue	• Consult with your installer, to add flue cowl or other solution
Fire will not light	• Too little combustion air	• Increase the setting of the air controller
	• Wet wood logs	• Use wood logs with 15-20% moisture content
	• Flue draft is too low	• Consult with your installer, to rectify
Fire burns too quickly	• Too much combustion air	• Reduce the setting of the air controller
	• Overly dry wood logs	• Use wood logs with 15-20% moisture content
	• Flue draft is too high	• Consult with your installer, to rectify

3. INSTALLATION INSTRUCTIONS

PLANNING THE INSTALLATION

It is the installer's responsibility to ensure that when installing the appliance, that all applicable Health and Safety requirements are met.

The installation instructions within this manual provide a guide for safe and appropriate installation, but it is the responsibility of the installer to ensure that the requirements of applicable standards, relating to the installation of solid fuel appliances. The appliance is heavy and care must be taken during handling. Although the appliance does not contain asbestos products, it is possible that asbestos may be disturbed in existing installations and every precaution must be taken.

When considering the installation design, ensure appropriate access is provided for cleaning of the appliance, flue pipe and chimney flue. This appliance is suitable for intermittent operation, but is not suitable for use in a shared flue system. The appliance should not be used in the same room as an extractor fan, as this can cause the stove to emit fumes into the room.

VENTILATION

All stoves require a consistent supply of 'combustion air', to allow for combustion of the fire. As a general rule, permanent external air vents are not required for stoves with a nominal output of 5kW or less. However, houses with a low air permeability, such as newer builds, may require a permanent external air vent. Typically, should a stove be installed in a room with an air permeability of lower than $5.0\text{m}^3/(\text{h.m}^2)$, a permanent external air vent is required, irrespective of the nominal output of the stove.

External air vents must be positioned so they are not liable to be blocked.

3. INSTALLATION INSTRUCTIONS

INSTALLING THE HEATSHIELD

Unit is supplied with a heat shield that is to be mounted to the wall.

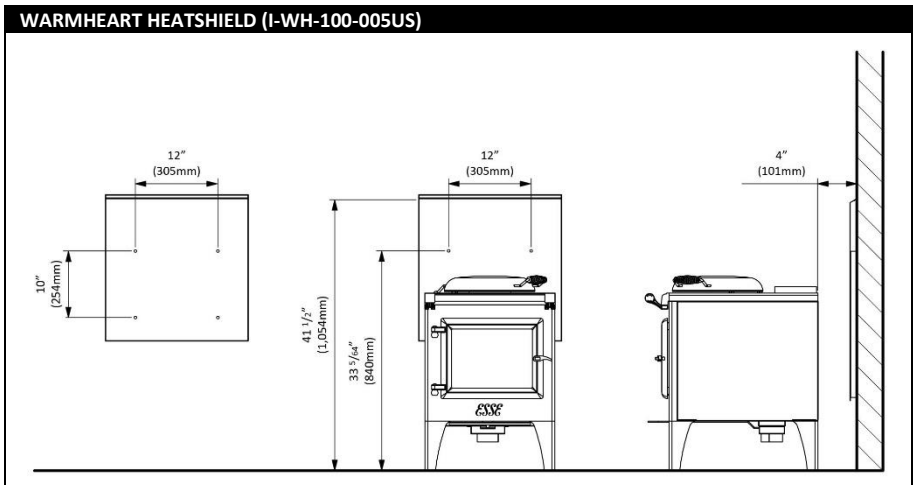
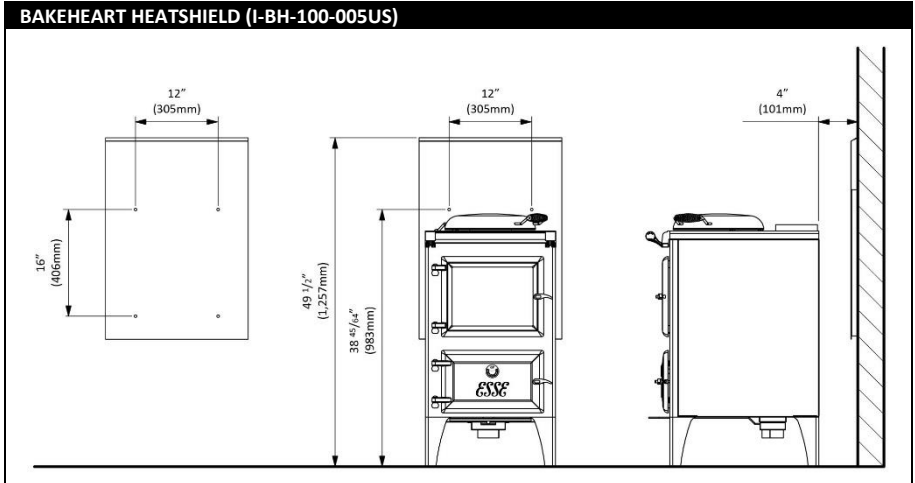

3. INSTALLATION INSTRUCTIONS

PRODUCT SPECIFICATION

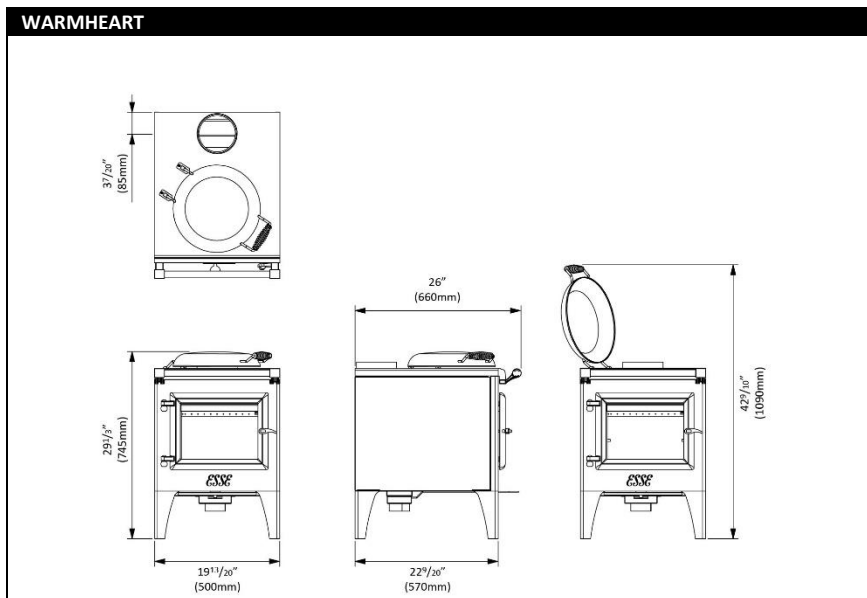
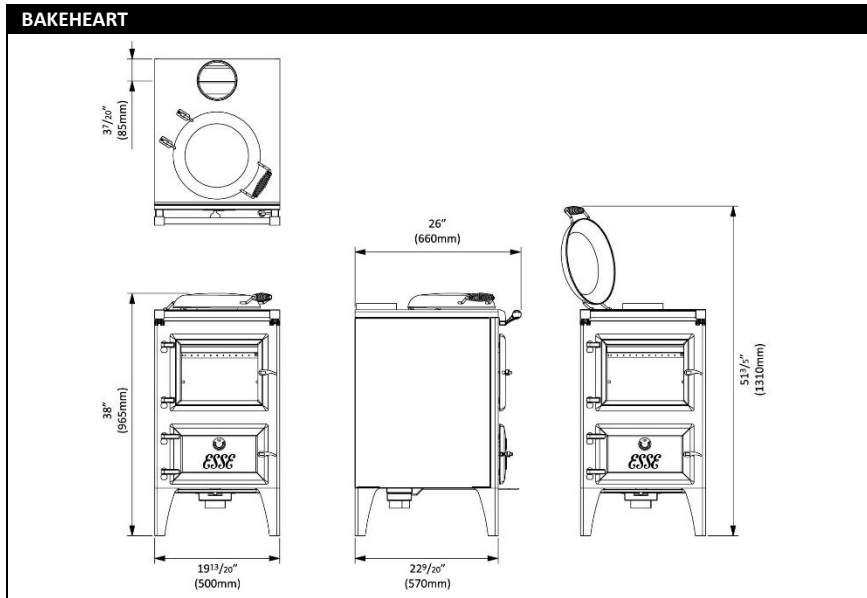

ESSE cook stoves are hand crafted, so small variations in size can occur.

3. INSTALLATION INSTRUCTIONS

Key Product Specifications		
	Bakeheart	Warmheart
Emissions	2.15 grams per hour	2.15 grams per hour
Efficiency	75.4%	75.4%
BTU Range	10,001 – 46,685	10,001 – 46,685
Weight (lbs)*	425	340
Minimum Flue Draft	12 Pa	12 Pa
Flue Diameter	6"	6"

CO AND SMOKE ALARM

Building regulations require that whenever a new or replacement fixed solid fuel or wood / biomass appliance is installed in a dwelling, a carbon monoxide (CO) and smoke alarm must be fitted in the same room as the appliance. The installation of an alarm must not be considered a substitute for either installing the appliance correctly, or ensuring regular servicing and maintenance of the appliance and chimney system.

UNPACKING THE APPLIANCE

The cook stove comes bolted and strapped to a pallet, for simple and secure transportation. To unpack, first remove the strapping and packaging. Then remove the two bolts holding the stove to the pallet. Whilst heat-treated, the pallet has been produced from timber that is appropriate for use as kindling, so can be broken up and chopped, for this purpose. Finally, dispose of the remaining packaging responsibly.

CHIMNEY & FLUE

The stove must be installed and connected to the chimney and flue pipe in line with the current requirements of Building Regulations. Where a prefabricated metal chimney is to be used, it must meet the requirements for Type HT chimneys in the Standard for Chimneys Factory-Built, Residential Type and Building Heating Appliance, UL 103, or High Temperature (650°C) Standard ULC S-629 for Canada. The cook stove is designed to be used with a 6" (150mm) flue connection.

3. INSTALLATION INSTRUCTIONS

As a basic guideline...

- ✓ The minimum chimney internal cross section area must be 6" (150mm) diameter, or 6"x6" (150mm x 150mm).
- ✓ The chimney must have a minimum height of 13' (4m) measured from the top of the stove to the top of the chimney.
- ✓ The chimney must extend at least 3' (915mm) above the highest point where it passes through a roof, and at least 2' (610mm) higher than any area of a building within 10' (3m).
- ✓ A twin walled flue can be used, but the first 13" (330mm) must be single wall, to allow the bolster lid to open.
- ✓ The chimney must have been swept before installation, and free from cracks, severe bends, voids and obstructions.
- ✓ Ensure where a flue pipe connects to a chimney, the flue passes past the point where the chimney narrows.
- ✓ A flue inspection hatch should be installed, to allow for a flue draft reading to be taken.
- ✓ Ensure an appropriate flue draft, as detailed within the Flue Draft section of this manual.
- ✓ Take into consideration future access for maintenance and sweeping.
- ✓ The flue must be capped / have a cowl, to prevent any ingress of rain.
- ✓ A single wall starter length with a single to twin wall adapter will be needed to use twin wall insulated flue. The stove will need to be moved away from the wall to accommodate use of twin wall flue.

Masonry Chimney

Ensure that a masonry chimney meets the minimum standards of the National Fire Protection Association (NFPA) by having it inspected by a professional. Make sure there are no cracks, loose mortar or other signs of deterioration and blockage. Have the chimney cleaned before the appliance is installed and operated. When connecting the appliance through a combustible wall to a masonry chimney, special methods are needed.

Factory Built Chimney

When a metal prefabricated chimney is used, the manufacturer's installation instructions must be followed. You must also purchase (from the same manufacturer) and install the ceiling support package or wall pass-through and

3. INSTALLATION INSTRUCTIONS

“T” section package, firestops (where needed), insulation shield, roof flashing, chimney cap, etc. maintain proper clearances to the structure as recommended by the manufacturer. The chimney must be the required height above the roof or other obstructions for safety and proper draft operation.

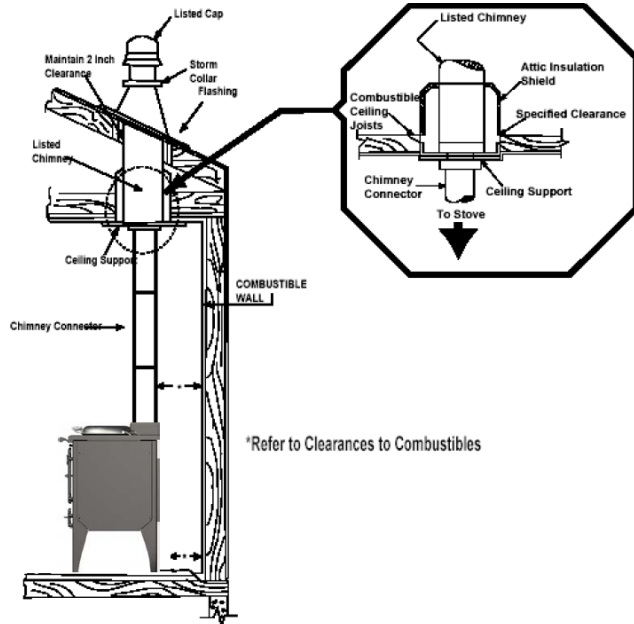

Connection through a combustible wall

Method A

Using a minimum thickness 3.5" (90mm) brick and a 5/8" (16mm) minimum wall thickness clay liner, construct a wall pass-through. The clay liner must conform to ASTM C315 (Standard Specification for Clay Fire Linings) or equivalent. Keep a minimum of 12" (305mm) of brick masonry between the clay liner and wall combustibles. The clay liner shall run from the brick masonry outer surface to the inner surface of the chimney flue liner but not past the inner surface. Firmly grout or cement the clay liner in place to the chimney flue liner.

3. INSTALLATION INSTRUCTIONS

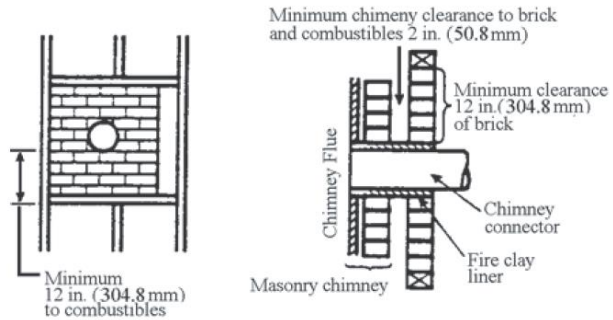

Method B

Using 6" (152mm) inside diameter, listed factory-built Solid-Pak chimney section with insulation of 1" (25mm) or more, build a wall pass-through with a minimum 9" (229mm) air space between the outer wall of the chimney length and wall combustibles. Use sheet metal supports fastened securely to wall surfaces on all sides to maintain the 9" (229mm) air space. When fastening supports to chimney length, do not penetrate the chimney liner (the inside wall of the Solid-Pak Chimney). The inner end of the Solid-Pak chimney section shall be flush with the inside of the masonry chimney flue, and sealed with a non-water soluble refractory cement. Use this cement to also seal to the brick masonry penetration.

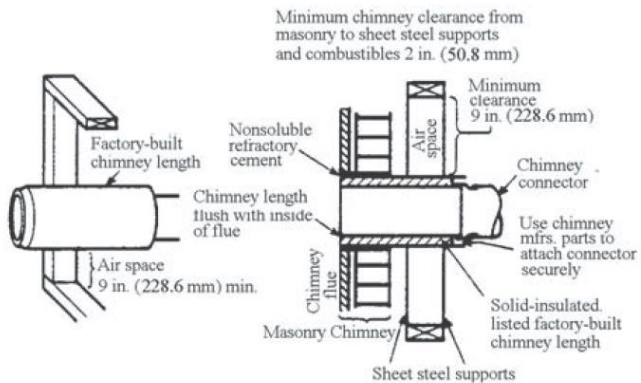

3. INSTALLATION INSTRUCTIONS

Method C

Starting with a minimum 24 gauge 0.024" (0.6mm) 6" (152mm) metal chimney connector, and a minimum 24 gauge ventilated wall thimble which has two air channels of 1" (25mm) each, construct a wall pass-through. There shall be a minimum 6" (152mm) separation area containing fiberglass insulation from the outer surface of the wall thimble to wall combustibles. Support the wall thimble, and cover its opening with a 24 gauge minimum sheet metal support maintaining the 6" (152mm) space. There should also be a support sized to fit and hold the metal chimney connector. See that the supports are fastened securely to wall surfaces on all sides. Make sure fasteners used to secure the metal chimney connector do not penetrate the chimney flue liner.

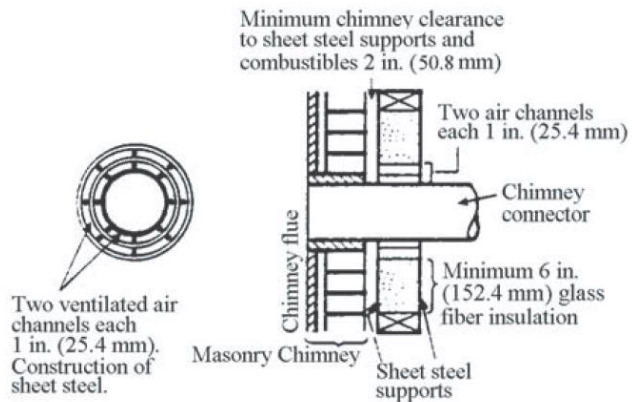

Method D

Start with a Solid-Pak listed factory built chimney section at least 12" (305mm) long, with insulation of 1" (25mm) or more, and an inside diameter of 8" (203mm) - 2" (50mm) larger than the 6" (152mm) chimney connector. Use this as a pass-through for a minimum 24 gauge single wall steel chimney connector. Keep the Solid-Pak section concentric with and spaced 1" (25mm) off the chimney connector by way of sheet metal support plates at both ends of the chimney section. Cover openings with and support the chimney section on both sides with 24 gauge minimum

3. INSTALLATION INSTRUCTIONS

sheet metal supports. Ensure that the supports are fastened securely to wall surfaces on all sides.

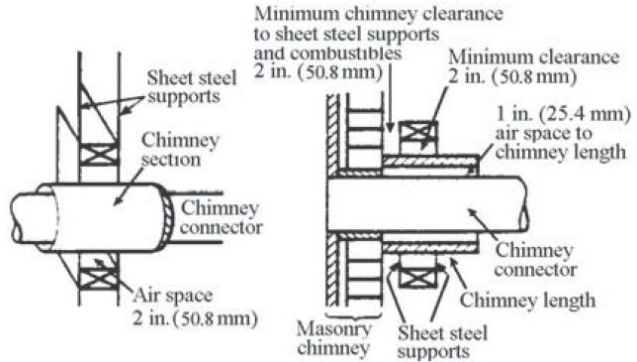

Note:

- Connectors to a masonry chimney, excepting method B, shall extend in one continuous section through the wall pass-through system and the chimney wall, up to but not past the inner flue liner face.
- A chimney connector shall not pass through an attic or roof space, closet or similar concealed space, floor, or ceiling.

CHIMNEY HEIGHT

A masonry chimney or a listed factory-built chimney must be the required height above the roof and any other nearby obstructions. The chimney must be at least 3' (90cm) higher than the highest point where it passes through the roof and at least 2' (60cm) higher than the highest part of the roof or structure that is within 10' (3m) of the chimney measured horizontally.

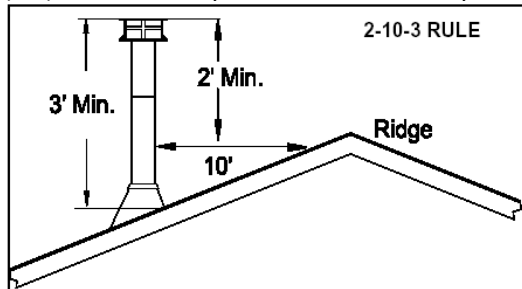

3. INSTALLATION INSTRUCTIONS

POSITIONING WITHIN A MASONRY FIREPLACE

The cook stove can be positioned within a masonry fireplace, but care must be given where a combustible mantelpiece or beam is incorporated.

Remember to incorporate enough room for the bolster lid to be fully opened.

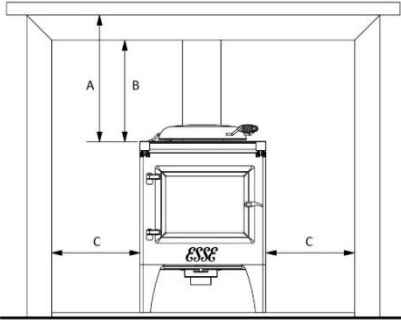

Where a mantelpiece or beam of combustible material, (such as wood), is used in the fireplace, it should be a minimum of 36" (920mm) from the appliance*. In some situations it may be necessary to shield the beam or mantelpiece to protect it. Shielding must be of non-combustible material spaced off the beam by at least ½" (12mm) on non-combustible spacers.

*This is an unlisted clearance distance, as per NFPA 211

Distances to non-combustible materials

	A	B	C
Minimum Distance	25" (635mm)	20" (508mm)	15" (381mm)

3. INSTALLATION INSTRUCTIONS

FLOOR PROTECTION

The cook stove must be placed upon a hearth or floor protector made from non-combustible material(s). The size of the hearth or floor protector must be in line with national requirements, in extending at least the minimum distance to the front, rear and sides of the appliance, and have a total size as indicated.

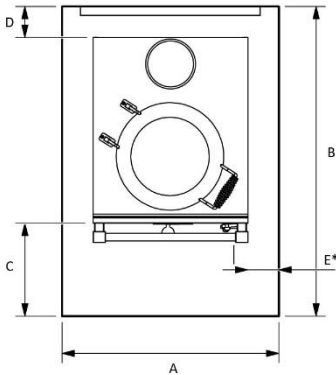

	USA	Canada
A	30" (762mm)	38" (965mm)
B	34" (864mm)	48.5" (1,232mm)
C	16" (406mm)	18" (460mm)
D	0" (0mm)	8" (203mm)
E	6" (152mm)	8" (203mm)

E* - From edge of firebox opening to outside edge of floor protection.

WALL CLEARANCES (CLEARANCE DISTANCES)

The cook stove must be placed an appropriate distance from combustible materials, to both the rear and sides. The Heatshield must be installed in conjunction with these wall clearance distances.

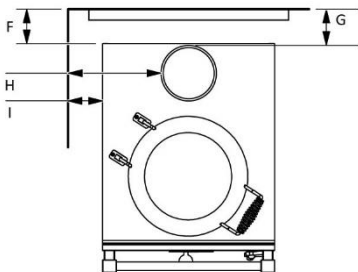

F	4" (101mm)
G	4.5" (114mm)
H	13.5" (343mm)
I	7" (178mm)

3. INSTALLATION INSTRUCTIONS

Check a single wall flue pipe is permitted with State and local officials, regarding the building code restrictions within your area. Clearance distances may only be reduced by means approved by the regulatory authority.

FLUE DRAFT

An appropriate flue draft is essential, for the stove to work safely and efficiently. When installed, and prior to commissioning, a flue draft reading should be taken, to ensure the draft is appropriate. A flue inspection hatch should be installed within the flue, to allow for a flue draft reading to be taken.

When both the cook stove and chimney are warm, a reading in a range between 1.25mm wg (12 Pa) and 2.5mm wg (25 Pa) should be expected. Any readings significantly outside this range are likely to cause problems, so further investigation should be undertaken so as to either reduce or increase the flue draft reading, as appropriate.

COMMISSIONING

Once the installation has been completed, check the flue and chimney connection is fully sealed, and complete a test lighting of the cook stove. Instruct the owner on how to use the appliance, and complete the Commissioning Checklist section of this manual. Finally, ensure that you leave this manual with the owner, for their reference.

3. INSTALLATION INSTRUCTIONS

Please complete, for the owners records and to support any future warranty claims.

Retailer information:

Name: _____

Address: _____

Telephone number: _____

Installation information: (Essential information - must be completed)

Date of installation: _____

ESSE model: _____

Serial number: _____

Installing engineer information:

Name: _____

Address: _____

Telephone number: _____

Commissioning checks: (To be completed & signed for)

Flue draft reading taken and recorded: _____ (Insert reading here)

Flue & chimney setup appropriate: Yes No

Flue & chimney swept & inspected: Yes No

Smoke test completed on appliance: Yes No

Clearance to combustibles checked: Yes No

CO and fire alarms fitted: Yes No

Operation of appliance explained to owner: Yes No

Instruction manual handed over to owner: Yes No

Signature: _____ Print name: _____

4. CONSUMABLE PARTS

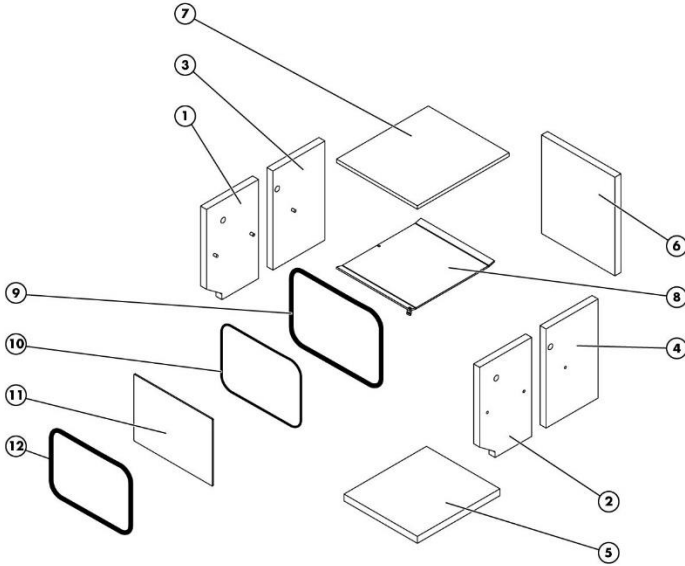

Item	Part No.	Description	Item	Part No.	Description
1	I-WH-100-006US	Front LHS Brick	7	I-WH-100-118US	Insulating Board
2	I-WH-100-009US	Front RHS Brick	8	I-WH-100-101US	Baffle
3	I-WH-100-007US	Rear LHS Brick	9	ROPE/CUT.GRY 13MM	Door Rope
4	I-WH-100-008US	Rear RHS Brick	10	ROPE/CUT.GRY 4MM	Glass Rope 2
5	I-WH-100-108US	Bottom Brick	11	500-IH-117	Ceramic Glass
6	I-WH-100-109US	Rear Brick	12	ROPE/CUT.GRY 3x15MM	Glass Rope 1

The Bolster Lid Rope Seals will also need replacing during the life of the cook stove.

The above consumable parts can be ordered through your retailer. If your retailer is unable to supply the consumable parts, or you would like to discuss the availability of spare parts, please contact ESSE directly



ESSE Engineering Ltd.,

Long Ing, Barnoldswick, Lancashire, BB18 6BJ, UK

Tel. 01282 813 235
Fax. 01282 816 876
Website www.esse.com