

# MODEL 91 CATALYTIC UNIT

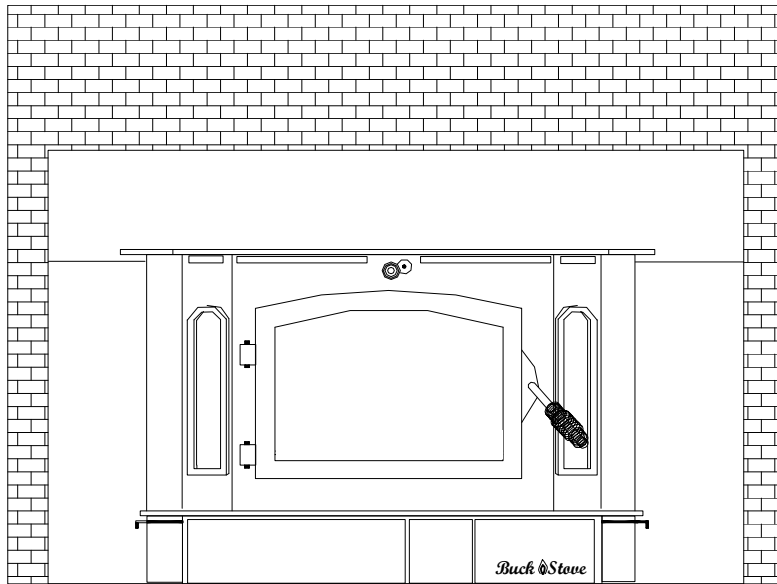

## FIREPLACE INSERT & FREESTANDING

### FEATURES

### PREPARATIONS

### INSTALLATION

### OPERATION

### MAINTENANCE

### SAFETY

## SAFETY NOTICE

**IF THIS HEATER IS NOT PROPERLY INSTALLED, A HOUSE FIRE MAY RESULT. FOR YOUR SAFETY, FOLLOW THE INSTALLATION INSTRUCTIONS. CONTACT THE AUTHORITY HAVING JURISDICTION (SUCH AS MUNICIPAL BUILDING DEPARTMENT, FIRE DEPARTMENT, FIRE PREVENTION BUREAU, etc.) CONSULT BEFORE INSTALLATION TO DETERMINE THE NEED TO OBTAIN A PERMIT. KEEP THESE INSTRUCTIONS FOR FUTURE USE.**

TESTED AND LISTED BY:



ITS/WARNOCK HERSEY, MIDDLETON, WI

**MANUFACTURED BY NEW BUCK CORPORATION  
200 ETHAN ALLEN DRIVE,  
SPRUCE PINE, N.C. 28777**

[www.buckstove.com](http://www.buckstove.com)

Revised January 2013



## TABLE OF CONTENTS

### SECTION I

Room Heater Features .....	3
Important Statements.....	3-6

### SECTION II

Masonry Insert Installation.....	7-11
----------------------------------	------

### SECTION III

Residential Freestanding Heater Installation.....	12-18
---	-------

### SECTION IV

Wood Heater Safety .....	19
--------------------------	----

### SECTION V

Operation.....	20-21
----------------	-------

### SECTION VI

Preventive Maintenance / Parts Replacement .....	22-25
--	-------

### SECTION VII

Troubleshooting .....	26-27
-----------------------	-------

<b>WARRANTY</b> .....	28
-----------------------	----



# SECTION I

The New Buck Corporation room heater Model 91 Bay is one of the safest and most efficient heating systems available when installed and operated as specified in these instructions and as stipulated on operation and installation labels affixed to unit. The unit is designed to burn wood fuel only.

Please read this entire manual before you install and use your new room heater. Failure to follow instructions may result in property damage, bodily injury or even death.

Throughout manual, you will see this symbol.  This indicates areas of importance regarding safety. Please make a special note of these areas.

Install and use only in accordance with manufacturer's installation and operating instructions. Do not connect this unit to a chimney flue serving another appliance. This unit is not designed for installation in a mobile home.

## ROOM HEATER FEATURES

Before attempting to install or operate your heater, it is a good idea to familiarize yourself with features and operating controls of unit. (See page 3 for reference).

## OPERATING CONTROLS

**WARNING:** Model 91 Bay Heater was not designed for fire grates.



**NOTE:** "Do not use grate or elevate fire. Build wood fire directly on hearth."

1. **Bypass Damper:** The bypass damper control is located in top center of heater front just under top. It is operated by pushing or pulling rod. The damper is fully open when handle is pulled out and fully closed when it is pushed in. The damper must be **OPEN** before door is opened.
2. **Blower Control:** The blower control (Rheostat) is located on side of the unit. The rheostat is used to vary speed of blower. It can be set at any position. It must be turned on to activate automatic thermostat on stove.
3. **Primary Air Controls:** The primary air intake draft controls (3) are located at left and right bottom side of hearth. They are operated by moving handle **out** to open (to allow air into the firebox) or **in** (to control or close off) air into firebox. Shotgun air control, allows air to center of firebox of stove (3a).
4. **Warm Air Outlets:** Provides heat extraction from top of firebox.
5. **Baffles:** Directs air flow around unit for maximum heat transfer.
6. **Air Inlet:** Allows cool air near floor to be circulated through blower and back into warm air chamber of heater.
7. **Door:** Provides an "airtight" feature. The door allows a much higher burning efficiency than can be obtained with an open firebox.
8. **Hearth Extension:** Offers protection from spilled ashes and cinders.
9. **Power Cord:** Provides electrical power to operate blower.
10. **Catalyst:** Enables Unit to burn cleanly and efficiently.
11. **Catalyst Probe:** Probe is located right of the bypass damper rod. It is used to determine (catalyst) temperature.
12. **Automatic/Off/Manual Switch:** Located behind right cover door under hearth. In the "Manual" position, the blower operates continuously. In "Automatic" position, blower is controlled by internal thermostat which reacts to temperature of air between the stove walls. (Not same as the temperature showing on the Catalyst Probe.)

## SAFETY STANDARD COMPLIANCE

The Model 91 Bay catalytic solid fuel (wood) burning combination room heater/fireplace stove manufactured by New Buck Corporation complies with UL 1482-(1996); UL 1482 (2006); UL 1482 (2010) and UL 737-1995 for residential freestanding and masonry fireplace insert installations when constructed and installed in accordance with ITS approved documentation.

## EPA COMPLIANCE STATUS

This manual describes installation and operation of the **New Buck Corporation Model 91 Bay** wood heater. This heater meets the U.S. Environmental Protection Agency's Emission limits for wood heaters sold after July 1, 1992. Under specific test conditions, this heater has been shown to deliver heat at rates ranging from approximately 10,000 to 54,500 BTU/hr for the Model 91 Bay.

## MODEL 91 WOOD STOVE IDENTIFICATION

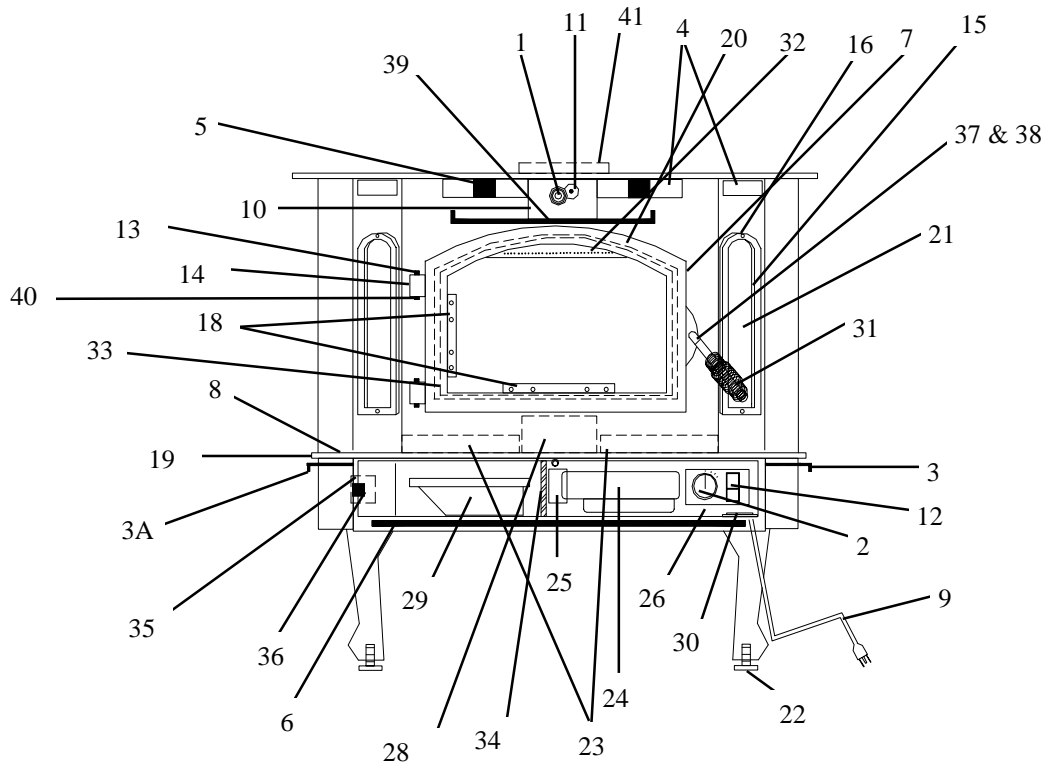

- |  |                                       |
|--|---------------------------------------|
| 1. Bypass Damper & Brass Spring Handle             | 20. Door Gasket                       |
| 2. Blower Control (Rheostat)                       | 21. Side Glass                        |
| 3. Primary Air Control Air Wash Rod for Both Sides | 22. Leveling Screws                   |
| 3a. Shotgun Air Control                            | 23. Firebrick                         |
| 4. Warm Air Outlets                                | 24. Motor                             |
| 5. Baffles (Interior of Stove)                     | 25. Motor Mount Bracket               |
| 6. Air Inlet                                       | 26. Cover Door                        |
| 7. Door  | 27. Cover Door Screws                 |
| 8. Hearth Extension                                | 28. Shotgun Air Box                   |
| 9. Power Cord                                      | 29. Ash Pan                           |
| 10. Catalyst (Interior Firebox)                    | 30. Disc Thermostat                   |
| 11. Catalyst Probe                                 | 31. Door Handle & Brass Spring Handle |
| 12. Automatic / Off / Manual Switch                | 32. Air Wash Screen                   |
| 13. Brass Cap                                      | 33. Glass Gasket                      |
| 14. Hinge Block                                    | 34. Cover Door Hinge                  |
| 15. Brass Overlays                                 | 35. Magnet Holder                     |
| 16. Brass Overlay Mounting Screws                  | 36. Cover Door Magnet                 |
| 17. Door Glass & Logo                              | 37. Door Latch                        |
| 18. Glass Clips                                    | 38. Door Latch Screw                  |
| 19. Hearth Brass                                   | 39. Lower Heat Shield                 |
|  | 40. Hinge Pins                        |
|  | 41. 8" Flue Exit                      |

## **CATALYST EQUIPPED**

This wood heater contains a catalytic combustor, which needs periodic inspection and replacement for proper operation. It is against law to operate this wood heater in a manner inconsistent with operating instructions in this manual or if the catalytic element is deactivated or removed.

## **CATALYST WARRANTY**

The combustor supplied with this heater is a set of (3) (2" x 3-1/2" x 6" x 25" cells). Consult catalytic combustor warranty also supplied with this heater. All warranty claims should be addressed to:

Applied Ceramics  
Customer Service Department  
P.O. Box 29664  
Atlanta, GA 30359  
770-448-6888

See enclosed catalyst warranty for instructions. New Buck Corporation does not handle catalyst replacements. Customer can order directly from Applied Ceramics.

## **PROPER FUEL SELECTION**

**For best results, this heater is designed to burn (dry), natural seasoned hardwood. Higher efficiencies and lower emissions generally result when burning air dried natural seasoned hardwoods, as compared to softwoods or too green or freshly cut hardwoods. Green or freshly cut hardwoods (wood with high moisture content) will not produce the BTU's needed to heat your home. The result will be low temperature reading on the catalyst probe, thus low BTU output.**

### **DO NOT BURN:**

- |                 |              |                  |          |
|-----------------|--------------|------------------|----------|
| 1) Treated Wood | 3) Garbage   | 5) Solvents      | 7) Trash |
| 2) Coal         | 4) Cardboard | 6) Colored Paper |          |

Burning treated wood, garbage, solvents, colored paper or trash may result in release of toxic fumes and may poison or render the catalytic combustor ineffective.

Burning coal, cardboard or loose paper can produce soot or large flakes of char or fly ash that can coat combustor, causing smoke spillage into room and rendering combustor ineffective. (Not covered under warranty.)

## **ACHIEVING CATALYTIC LIGHT-OFF**

The temperature in stove and gases entering combustor must be raised to between 700° F to 900° F for catalytic activity to be initiated. The temperature can be determined by the Catalyst Monitor Probe. During start up of a cold stove a medium to high firing rate must be maintained for about 20 minutes. This can be achieved by starting fire with dry kindling, paper and small split wood. Have the Bypass Damper fully open (pulled out). This ensures that the stove, catalyst and fuel are all stabilized at proper operating temperatures. Even though it is possible (and likely) to have gas temperatures reach 600° F within two to three minutes after a fire is started, if the fire is allowed to die down immediately it may go out or the combustor may stop working. Once the combustor starts working, heat generated in it by burning smoke will keep it working.

## **ACHIEVING CATALYTIC LIGHT-OFF WHEN REFUELING**

During refueling and rekindling of a cool fire, or a fire that has burned down to charcoal phase, operate stove at a medium to high firing rate for about 10 minutes to ensure that catalyst reaches approximately 800° F.

## CATALYST MONITORING

It is important to periodically monitor operation of catalytic combustor to ensure that it is functioning properly, and to determine when it needs to be replaced. A non-functioning combustor will result in a loss of heating efficiency and an increase in creosote and emissions. See Troubleshooting section for detailed instructions **BEFORE** attempting to remove catalyst.

This catalytic heater is equipped with means to monitor catalyst operation. Properly functioning combustors typically maintain temperatures in excess of 1000° F. If catalyst temperatures are not in excess of 500° F, refer to Catalyst Troubleshooting section of this owner's manual.



### CAUTION AGAINST OVER-FIRING

**Do not over-fire this heater.**

Attempts to achieve heat output rates that exceed heater design specifications can result in permanent damage to the heater and to catalytic combustor.

## ASH REMOVAL

Whenever ashes build up in firebox and when fire has burned down and cooled, remove excess ashes. Leave an ash bed approximately 1 inch deep on firebox bottom to help maintain a hot charcoal bed. To remove ashes the dump is located at left inner bottom. By lifting dump door, place ashes through the dump opening. The ashes fall directly into ash pan. The ash pan is located at left side under the hearth behind cover door.

**NOTE:** Be sure to turn room air blower off before removing ashes. Open cover door and slide ash pan out.

**NOTE:** Fueling and ash removal door (s) must remain closed when in operation.

Ashes should be placed in a metal container with a tight fitting lid. The closed container of ashes should be placed on a non-combustible floor or on ground, away from all combustible materials, pending final disposal. The ashes should be retained in the closed container until all cinders have thoroughly cooled.

**NOTE:** Be sure to turn room air blower back on when job is completed.

**NOTE:** The room heater is not to be connected to any air distribution duct.

## CREOSOTE - FORMATION AND NEED FOR REMOVAL

When wood is burned slowly, it produces tar and other organic vapor, which combined with expelled moisture forms creosote. The creosote vapors condense in a relatively cool chimney flue of a slow-burning fire. As a result, creosote residue accumulates on flue lining. When ignited, this creosote makes an extremely hot fire.



# SECTION II

## MASONRY INSERT INSTALLATION INSTALLATION OPTIONS

This unit (appliance) may be installed into an all masonry fireplace, built in accordance with Uniform Building Code and National Fire Protection Association (NFPA 211).

**NOTE:** Check with local building officials for any permits required for installation of this stove and notify your insurance company before proceeding with installation.

OPTION A. See Below

At a minimum, a **starter pipe** reaching from stove flue exit to base of existing code approved masonry chimney (flue-liner) and an airtight face seal.

OPTION B. See Page 8.

**Direct connection:** In accordance with **NFPA-211-9-4.5, Connection to Masonry Fireplaces**. A solid fuel-burning appliance such as a stove or insert shall be permitted to use a masonry fireplace flue where the following conditions are met:

*Exception: Listed fireplace accessories shall be permitted to use a masonry fireplace flue.*

1. There is a connector that extends from the appliance to flue liner.
2. The cross-sectional area of flue is no more than three times the cross-sectional area of flue collar of appliance.
3. If appliance vents directly through chimney wall above smoke chamber, there shall be a noncombustible seal below the entry point of the connector.
4. The installation shall be such that the chimney system can be inspected and cleaned.
5. Means shall be provided to prevent dilution of combustible products in the chimney flue with air from the habitable space.

OPTION C. See Page 8.

It may be necessary to **positive connect** this unit to enhance the performance, if any of the following conditions exists:

- |                             |                 |   |
|-----------------------------|-----------------|---|
| 1. Poor Drawing Flue        | 3. Double Flues | 5. Stone Front Fireplace/ or damaged flue liner |
| 2. Oversized Flue (17" x 7) | 4. Ash Dump     | 6. Chimney that does not exceed 12'             |

Check with your dealer if any of above conditions exist before installing your stove. Proper installation is critical to the performance of the Model 91.

Use Fireplace Kit PA FP91 for installation. An optional oversized fireplace kit is available for larger fireplaces. Check with dealer.

### SAFETY NOTICE

**If this appliance is not properly installed, a house fire may result. For your safety, follow the installation directions. Contact local building or fire officials about restrictions and installation inspection requirements in your area.**

### OPTION (A)

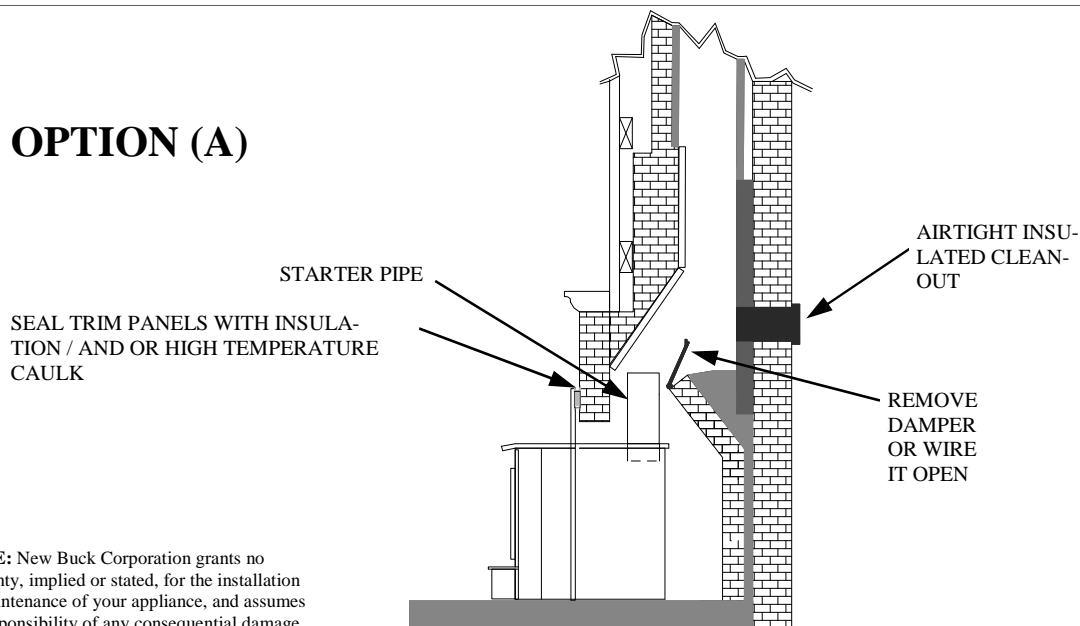

**NOTE:** New Buck Corporation grants no warranty, implied or stated, for the installation or maintenance of your appliance, and assumes no responsibility of any consequential damage

## OPTION (B)

**NOTE:** Follow installation instruction with Direct Connection Kit. (Kit sold separately)

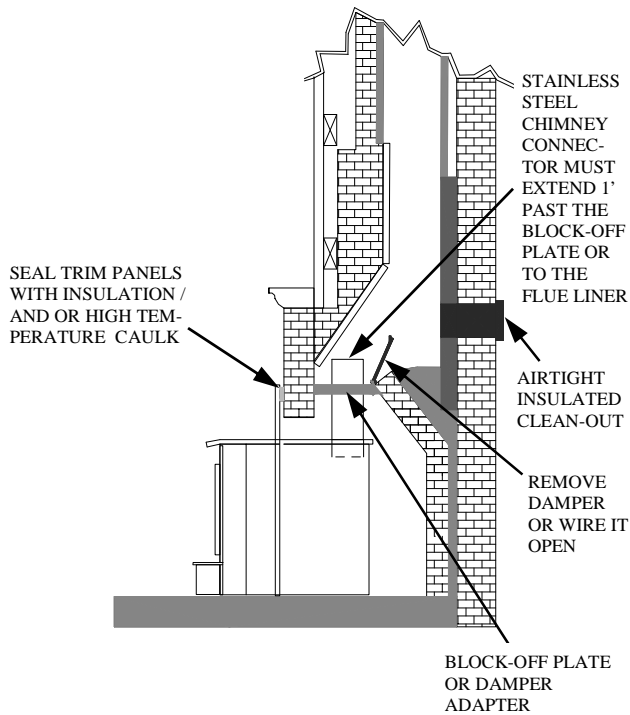

## OPTION (C)

**NOTE:** Follow installation instruction with Positive Connection Kit. (Kit sold separately)

INSTALL A NON-COMBUSTIBLE COVER PLATE TO PREVENT WATER FROM ENTERING THE CHIMNEY

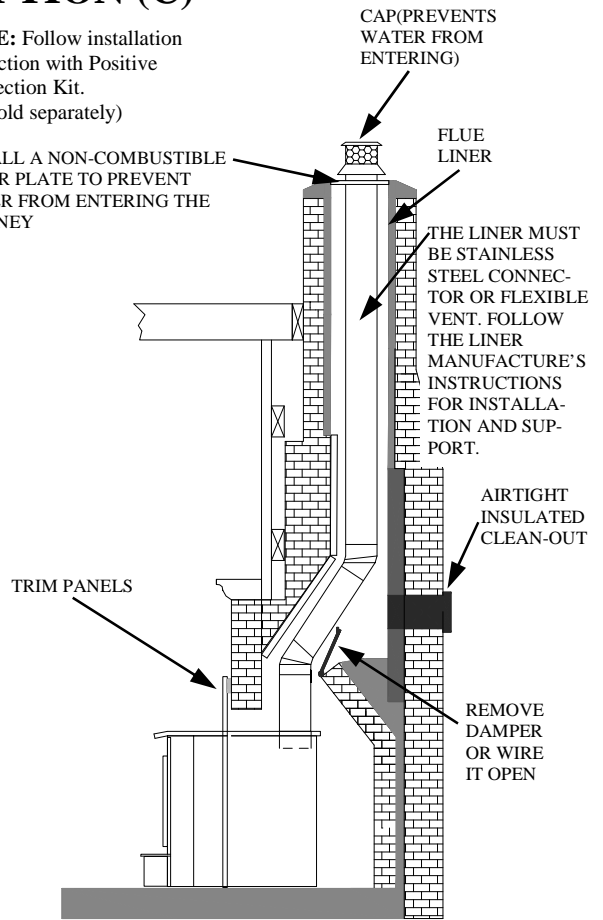

## INSTALLATION (Fireplace Insert)

Minimum Clearances to Combustible Materials (in inches)

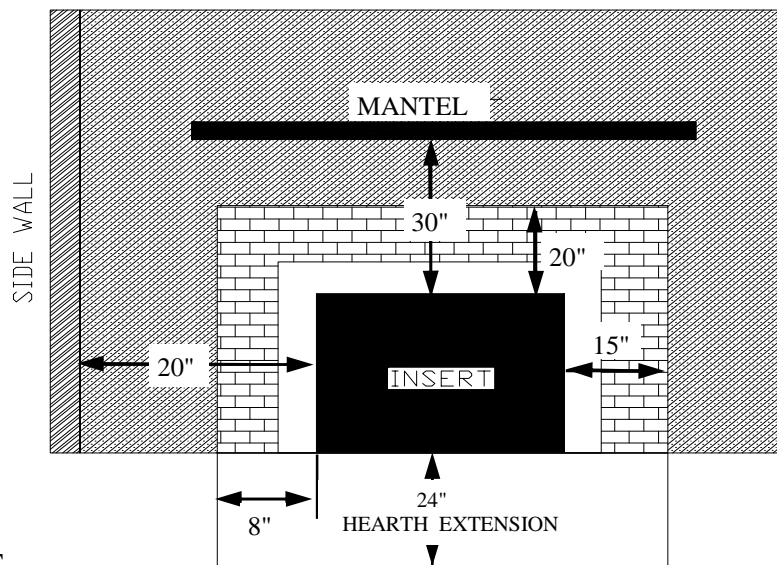

**FIGURE 1**  
**FIREPLACE INSERT**

## MINIMUM CLEARANCES:

The Model 91 Bay Fireplace Insert is intended for installation in accordance with standard for chimneys, fireplaces, vents and solid-fuel burning appliances. **NFPA-211 Code: NOTE-**This model is not intended for installation into Zero Clearance or pre-fabricated fireplace.

1. The hearth must be of masonry construction and must extend a minimum of 24" in front of firebox opening and a minimum of 8" to either side of firebox opening.
2. Floor protector must be 3/8" minimum thickness non-combustible material or equivalent.
3. If your fireplace has wood trim above it, the wood trim must be at least 20" above top of unit and may be a maximum of 1/2" thick.
4. If your fireplace has a wood mantel, mantel or mantel supports must be located at a height of 30" above top of the stove.

## REQUIRED FIREPLACE DIMENSIONS

Minimum fireplace dimensions:

	<b>Height Min.</b>	<b>Width Min.</b>	<b>Depth Min.</b>
Model 91 Bay	23 1/2"	31 3/4"	15 1/2"

## POSSIBLE TOOLS NEEDED FOR INSTALLATION

If you decide to install your own stove, there are several hand tools you may need to do job. If you do not already have them, they are readily available at most hardware stores.

Caulking gun

Large adjustable wrench (may not be needed)

Drop cloths or newspapers

Vacuum cleaner or whisk broom

Flashlight

1 tube of RTV silicone, Code 103 or 106, or high temperature rubber cement rated between 450° F- 600° F.

7/32" drill bit and drill

Socket/Ratchet Set

Insulation (Provided in Trim Kit package)

## INSTALLATION PREPARATION

### Fireplace:

1. Locate furniture and other materials away from front of fireplace to allow free access to fireplace.
2. Cover hearth and adjacent floor areas with drop cloths to protect from soiling or marring surface.
3. Remove existing fireplace damper plate.
4. Thoroughly clean the fireplace of ashes and soot.
5. Have your existing chimney inspected before inserting this unit. Some chimneys must be relined or replaced before they are safe to use.
6. Check the chimney and smoke chamber for excessive buildups of creosote or soot. Also, check for obstructions, such as bird's nests. If chimney is excessively dirty, clean it or have someone clean it professionally **BEFORE** installing or using room heater.
7. If fireplace has an ash dump or outside air provision, these must be sealed off with metal or tightly packed non-combustible insulation to prevent cold air from entering fireplace chamber.

### Heater:

1. Inspect unit for any obvious physical damage.
2. Check primary air draft controls to ensure that they slide freely.
3. Check operation of damper control to ensure it will open and close properly.
4. Check Manual/Automatic Switch to ensure that motor is working. \*Place switch in the "MANUAL" position. (Plug in stove.) You cannot check motor in the "AUTOMATIC" position, unless a heat gun is used to heat internal thermostat.

## POSITIONING THE HEATER

When positioning heater, the following conditions **MUST** be met! (See Figure 2.)

1. The front of damper opening must be positioned **BEHIND** rear edge of lintel to ensure proper draft. (See Figure 2.)
2. The vertical plane of fireplace front must fall **BEHIND** side panels of the unit. (In other words, it is possible to have heater too far in as well as not far enough.)
3. Center the heater in fireplace opening.

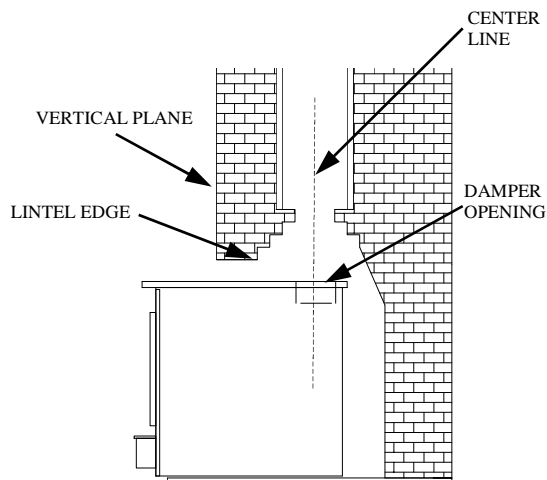

FIGURE 2 POSITIONING

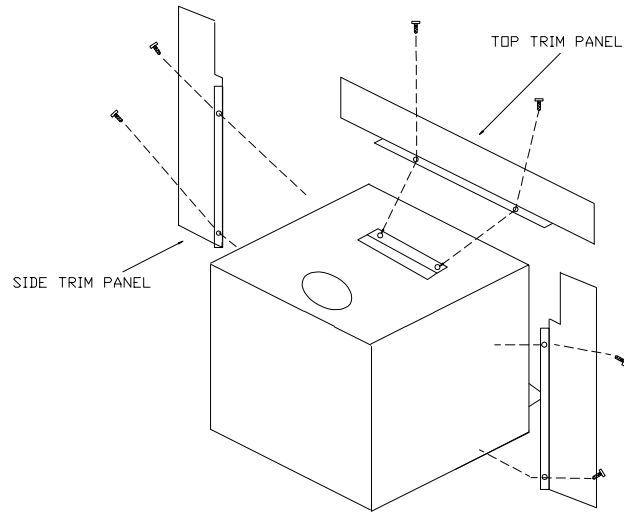

FIGURE 3 MOUNTING TRIM PANELS

## MOUNTING TRIM PANELS

After unit is positioned, mark mounting position of trim panels as follows:

1. Place side trim panels flat against face of fireplace. Mark inside edge of trim panel to make a vertical reference line. (See Figure 3.)
2. Place top (long) trim panel on top of unit. The panel should be flat against outside face of fireplace, and standing vertically. Mark lower edge of trim panel with a pencil to make a reference line for mounting.
3. Slide unit out of fireplace far enough to work behind trim panel reference lines.
4. Mount side trim panels. (See Figure 3.)
  - a. Position trim panel on reference line.
  - b. Drill mounting holes in center of trim panel mounting brackets to allow for adjustment in and out if necessary.
  - c. Mount trim panel using self-tapping screws provided.
5. Place top panel back on reference mark. Top trim panel mounting bracket is supplied with unit. Position bracket so it overlaps rear lip of top trim panel. Drill mounting holes in top of stove using holes in bracket as guide. Tighten screws.
6. Follow installation procedures in listed direct connect or positive connect kit you are using and install heater and connect kit in fireplace.

7. Slide unit back into fireplace. Check to be sure that trim panels are properly positioned and lie flat against front of fireplace. If one or more of panels is out of position, slide unit out and reset by loosening mounting screws and repositioning in slot.
8. Reinstall top trim panel by sliding rear lip of top trim panel underneath front lip of mounting bracket already secured to top of unit.  
**NOTE:** Mount top trim panel so that it sits in front of top of side trim panels..
9. Obtain brass trim kit provided with unit and slip over top and sides of trim panels. (Top ends of brass may need to be trimmed to fit.)
10. Ensure that starter pipe or connector is properly secure in stove flue exit, and aligned with chimney flue.
11. Mount top trim panel by drilling mounting holes in center of trim panel mounting brackets, with top end side of top panel overlapping side panel.
12. Using insulation provided, peel and stick to back of panels overlapping fireplace dimensions by 1" on each side and top. (See Figure 3.)
13. Using high heat silicone or furnace cement run heavy bead of caulking where panels meet stove. (See Figure 3.)
14. Slide unit back into fireplace. Check to be sure that trim panels (and brass) are properly positioned and lie flat against front of fireplace. If panels are out of position, slide unit out and reset by loosening mounting screws and repositioning in slot. With bar, lift stove up in front. Place insulation across front and surface of hearth or bottom of fireplace to make complete seal.
15. To check seal of panels, use candle flame and go around entire area sealed by silicone and insulation. If flame leans toward inside of fireplace, add additional insulation. This ensures an airtight seal.

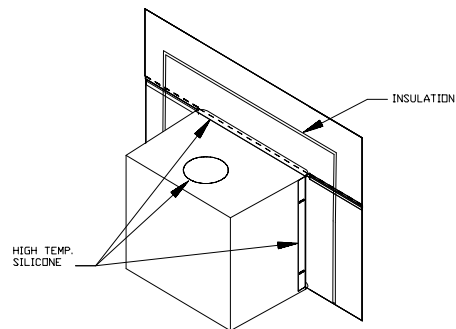

## FINAL CHECK

1. Recheck specified clearances.
2. Remove all foreign material from firebox area.
3. Open primary air draft, shot-gun air draft and damper bypass, make sure ash drawer is sealed properly.
4. Plug power cord into a 115V AC outlet. Set switch to "Manual" and rheostat to "High" position to ensure motor operates properly.
5. Place 4 or 5 pieces of newspaper in stove. Light paper and close door. Ensure that stove draws properly through primary drafts.
6. Check for smoke leaks around door.
7. Open door (slowly) and check for smoke escaping from front of stove. Smoking usually indicates a defective or poorly positioned chimney. Some chimneys with a marginal draft can be preheated by lighting newspaper and holding it near the open damper with a poker or fire tong. Once chimney heats up, a proper draft can usually be obtained.  
**NOTE:** A poor drafting chimney can lead to poor heater performance. This is not a defect of the heater, but with the chimney. Poor performance due to a poor drafting chimney is **NOT** a warranty problem. If a thorough review of Troubleshooting Guide in rear of manual does not solve your problem, contact your dealer for assistance. If homeowner installed unit himself, there generally is a charge for dealer to service the stove and inspect installation.
8. The unit is painted with a specially formulated high temperature paint that cures during the first two or three firings. **DO NOT BUILD A LARGE ROARING FIRE UNTIL THIS CURING IS COMPLETE OR HEATER FINISH MAY BE DAMAGED.** (Paint may blister or peel off. This is not covered by warranty.) You may notice a slight smoking effect and an odor of burning paint when you build the first fires. This is normal and is not a cause for alarm. In some cases these fumes will activate a smoke alarm. Opening a window near unit will allow these fumes to escape.

## SECTION III

### RESIDENTIAL FREESTANDING ROOM HEATER INSTALLATION

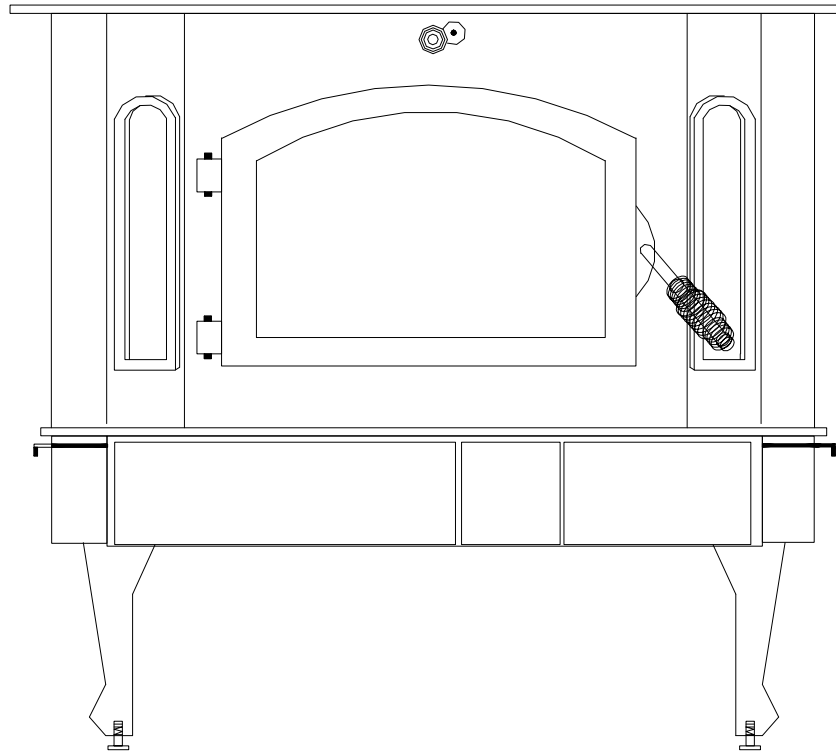

### INSTALLATION PRECAUTION

Extensive field and laboratory testing has shown that catalytic stoves perform best as freestanding stoves when vented into a masonry chimney that include the following:

1. A rain cap is installed on chimney.
2. Height of chimney is at least 15 feet high.
3. Location of chimney is interior. (Not on an outside wall)

Satisfactory results have been reported with installations other than listed above. However, draft problems are possible if a hot chimney is not maintained.

Use Leg Kit # FA FS2191 for Model 91



**CAUTION:** Do not connect this unit to a chimney flue serving another appliance.

# MODEL 91 BAY

## MINIMUM CLEARANCES

The New Buck Corporation Model 91 Bay must be installed in compliance with instructions contained in this manual.

### Clearance from combustable walls and ceilings. (Using single wall chimney connector)

The minimum lateral distance between any part of room heater and combustable walls is shown in Figures 1 and 2.

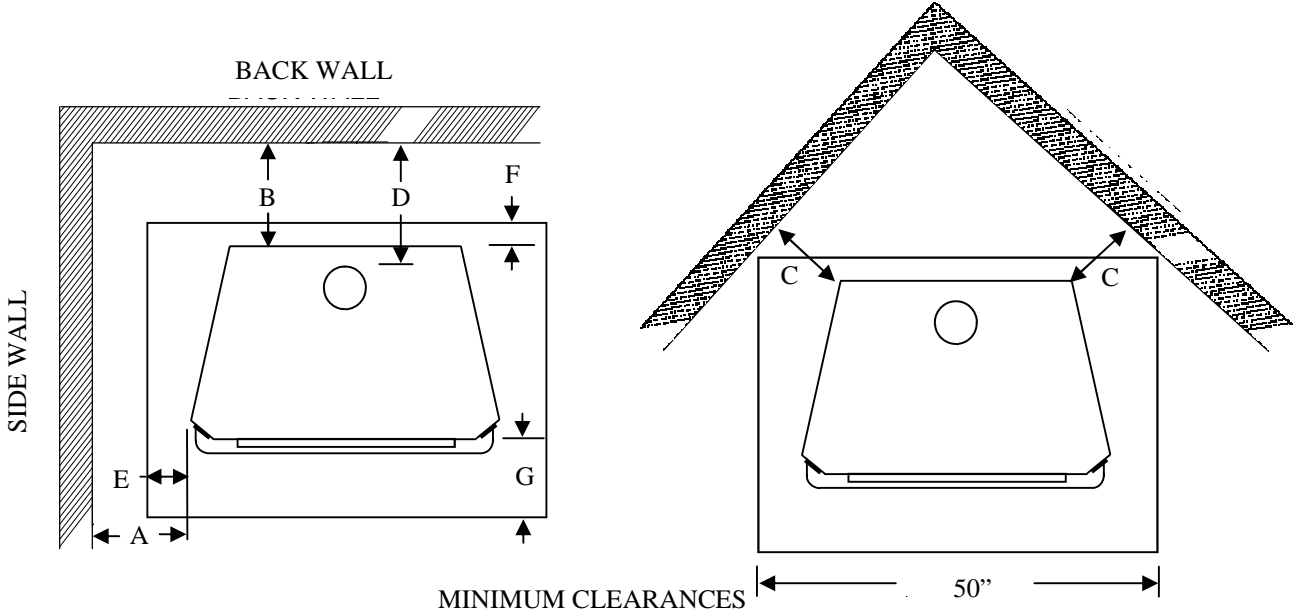

FIGURE 1

MINIMUM CLEARANCES

FIGURE 2

	A	B	C	D	E	F	G
MODEL 91	24"	23"	16"	26"	8"	3"	16"

## FLOOR PROTECTION

If a freestanding model is to be installed on a combustable floor, a non-combustible pad must be placed under unit to protect floor from burning material from stove. The pad must be 50 inches wide. **NOTE:** The floor must extend 16" from door opening in front of stove, 8" from door opening on each side of unit and should be under the chimney connector. Floor protector must be 3/8" in minimum thickness, non-combustible material or equivalent.

**NOTE:** For clearance reductions using wall protectors, refer to the **NFPA-211** Code.

## TOOLS FOR INSTALLATION

- Drop Cloth
- Electric Drill with 7/32" drill bit
- 1/2" - 9/16" combination wrench
- 3/8" magnetic socket chuck adapter, 3/8" wrench (box or socket) or adjustable wrench
- Socket Set
- Tape Measure
- Pencil
- Level
- Screw Driver

# MINIMUM CLEARANCES

## FLOOR PROTECTION

Floor protector must be 3/8" minimum thickness non-combustible material or equivalent.

### How to use alternate materials and how to calculate equivalent thickness

An easy means of determining if a proposed alternate floor protector meets requirements listed in the appliance manual is to follow this procedure:

1. Convert specification to R-value:
  - R-value is given—no conversion is needed.
  - K-factor is given with a required thickness (T) in inches:  
C-factor is given:  $R=1/C$
2. Determine the R-value of the proposed alternate floor protector.
  - Use the formula in step (1) to convert values not expressed as "R"
  - For multiple layers, add R-values of each layer to determine the overall R-value.
3. If the overall R-value of the system is greater than the R-value of the specified floor protector, the alternate is acceptable.

### Example:

The specified floor protector should be 3/4" thick material with a K-factor of 0.84.  
The proposed alternate is 4" brick with a C-factor of 1.25 over 1/8" mineral board with a K-factor of 0.29.

Step (a): Use formula above to convert specification to R-value.  $R= 1/K \times T = 1/0.84 \times .75 = 0.893$

Step (b): Calculate R of proposed system. 4" brick of  $C=1.25$ , therefore  $R_{brick} = 1/C = 1/1.25 = 0.80$   
1/8" mineral board of  $K = 0.29$ , therefore  $R_{min.bd.} = 1/0.29 \times 0.125 = 0.431$

Step (c): Compare proposed system R of 1.231 to specified R of 0.893. Since proposed system R is greater than required, the system is acceptable.

Definitions:

$$\text{Thermal conductance} = C = \frac{\text{Btu}}{(\text{hr})(\text{ft}^2)(\text{°F})} = \frac{\text{W}}{(\text{m}^2)(\text{°K})}$$

$$\text{Thermal conductance} = K = \frac{(\text{Btu})(\text{inch})}{(\text{hr})(\text{ft}^2)(\text{°F})} = \frac{\text{W}}{(\text{m})(\text{°K})} = \frac{(\text{Btu})}{(\text{hr})(\text{ft})(\text{°F})}$$

$$\text{Thermal conductance} = R = \frac{(\text{ft}^2)(\text{hr})(\text{°F})}{\text{Btu}} = \frac{(\text{m}^2)(\text{°K})}{\text{W}}$$

Install in accordance with 24 CFR, Part 3280 (HUD).



## PREPARING THE STOVE FOR INSTALLATION

1. Inspect unit for any obvious physical damage.
2. Plug power cord into a **115V AC** outlet. Set switch to “Manual” and rheostat to “High” position to ensure motor operates properly. You cannot check motor when switch is in the “Off” or “Automatic” position, unless a heat gun is used to heat internal thermostat.
3. Check primary air draft controls to ensure that they operate freely.
4. Check operation of bypass damper control to ensure that it will open and close properly.
5. To attach legs, remove any items within firebox. Spread drop cloth on floor behind heater. Tilt heater so that back is on drop cloth. Attach legs to pre-drilled holes in bottom of heater. If using optional pedestal, mounting holes will need to be drilled.
6. Reposition heater to upright position.

## CHIMNEY

### Ceiling Exits:

The Model 91 Bay is designed for connection to: 1) Simpson Dura-Vent, 2) Security, 3) Selkirk Metal 4) Metal Fab, 5) Air Jet, listed as 2100° pipe and parts.

“Follow chimney and chimney connector manufacturers instructions and local building codes for installation through combustibile walls or ceilings.” This heater can only be installed freestanding by using one of the following requirements: 1) must use a brand of chimney pipe, as listed above, complying to the requirements for Type HT chimneys in the standard code for chimneys, Factory-Built, Residential Type and Building Heating Appliance, UL 103 or 2) a code approved masonry chimney with a flue liner.

**CAUTION:** Certain installation types require use of certain chimney types. Please follow these instructions exactly.

### DETERMINING CHIMNEY LOCATION

#### A. Ceiling Exit (Using Single Wall Pipe and UL 103 HT type chimney system listed with manufacturers in this section of manual)

1. Suspend a plumb bob from ceiling above unit so that weight is hanging in the center of flue exit. (A small weight on a string will serve as a plumb bob.) Mark ceiling where string is suspended to locate center of chimney.
2. After locating the center of the hole, install the ceiling support box, chimney, flashing, and rain cap per the chimney manufacturer’s instructions.
3. Connect stove to ceiling support box by using #24 ga. minimum blued or black steel chimney pipe. (DO NOT use galvanized pipe.) Each section should fit into section below or into opening on stove, for drip-free operation. Secure each section together by using at least three (3) sheet metal screws or rivets.
4. You may secure chimney pipe to stove two (2) different ways.
  - a. With Optional NBC Cast Chimney Connector, See Figure 3.
  - b. Mounting clips attached to heater and chimney pipe, See Figure 7 on Page 16.

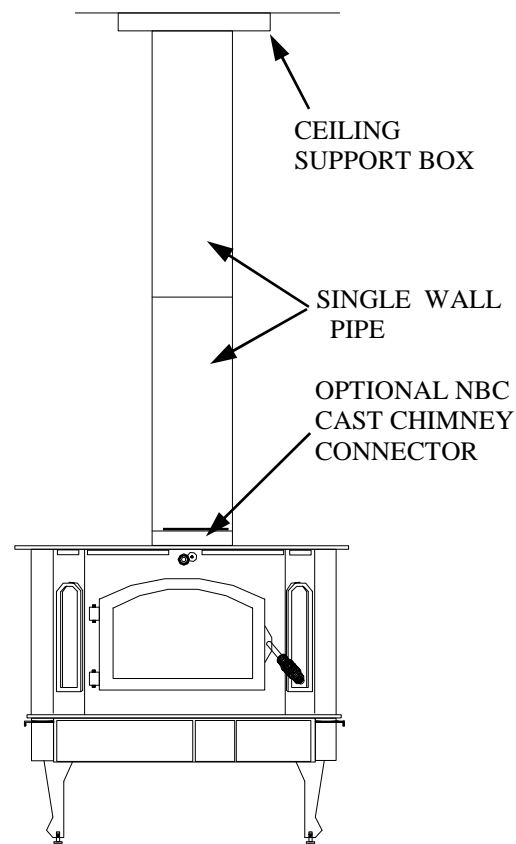
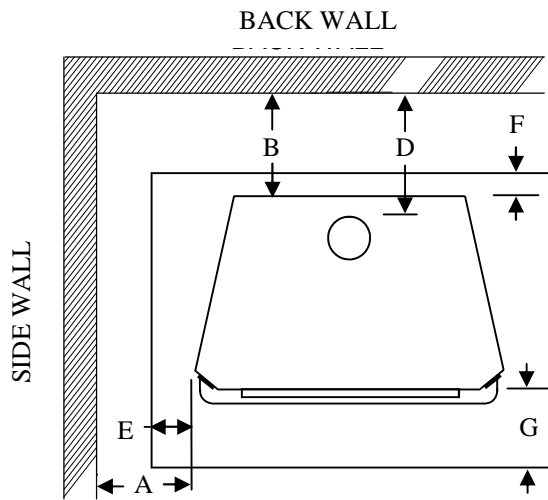

FIGURE 3

# CLOSE CLEARANCE INSTALLATIONS (in inches)

Close clearance installation is possible by using the following brands of black, double-wall chimney pipe. (See Figure 4 and Figure 5 for clearances.)

1. Simpson Dura-Vent double wall chimney connector "Type DVL" and 8" Simpson Dura-Vent 2100° HT "Type DP" chimney
2. 8" Security Type DL double wall connector and 8" Security Type "ASHT" High Temp Chimney.
3. 8" Selkirk Metal Bestos Model "DS" double wall connector-8" Selkirk Metal Bestos Model SSII type HT Chimney System.
4. 8" Metal Fab type "DW" double wall connector - 8" Metal Fab 2100° HT chimney.
5. 8" Air Jet



**FIGURE 4** MINIMUM CLEARANCES

	A	B	C	D	E	F	G
MODEL 91	14"	14"	12"	16"	8"	8"	16"

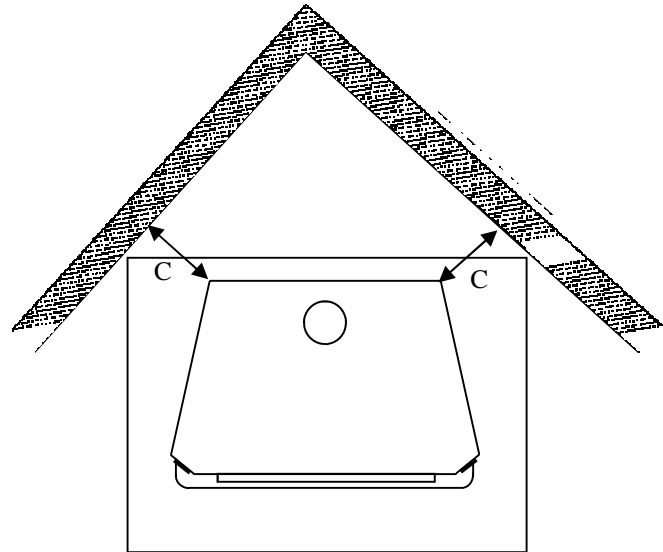

**FIGURE 5**

## TOOLS FOR INSTALLATION

- Drop Cloth
- Electric Drill with 3/32" drill bit
- 5/16" combination wrench
- 5/16" magnetic socket chuck adapter, 5/16" wrench (box or socket) or adjustable wrench
- Pencil
- Socket Set
- Level
- Tape Measure
- Screw Driver

### Wall Exit into Metal Tee-Box (Using Single Wall Pipe)

1. Mark plumb line on the wall directly behind the center of heater. (See Figure 6.)

**NOTE:** When using #24 ga. min. blued or black steel pipe, maintain 18" between pipe and ceiling.

2. Place vertical portion of heater pipe and elbow in position and project a point onto plumb line level with center of elbow.

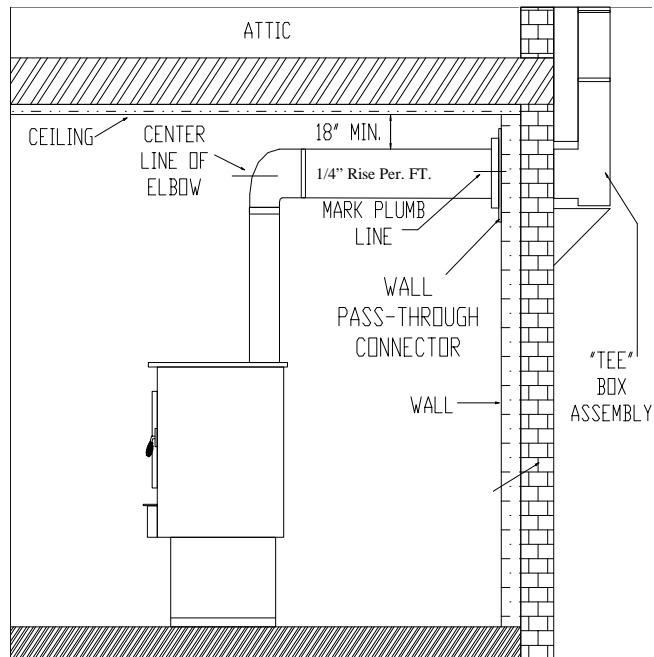

**FIGURE 6**

3. Measure so there will be at least 1/4" rise per foot of horizontal connector pipe, maintaining clearances to ceiling as noted in Figure 7. This will give you the center of hole for chimney penetration.
4. After locating center of penetration, install tee-box and chimney as per chimney manufacturer's specifications.
5. Connect chimney pipe to tee-box using #24 ga. minimum blued or black steel pipe. (DO NOT use galvanized pipe.) Each section should fit into section below or into opening on stove, for drip-free operation. Secure each section together by using at least three (3) sheet metal screws or rivets.

**Wall Exit Into Masonry  
(Using Single Wall Pipe)**

1. Before connecting Model 91 Bay to a masonry chimney, determine if masonry fireplace wall pass-through connector

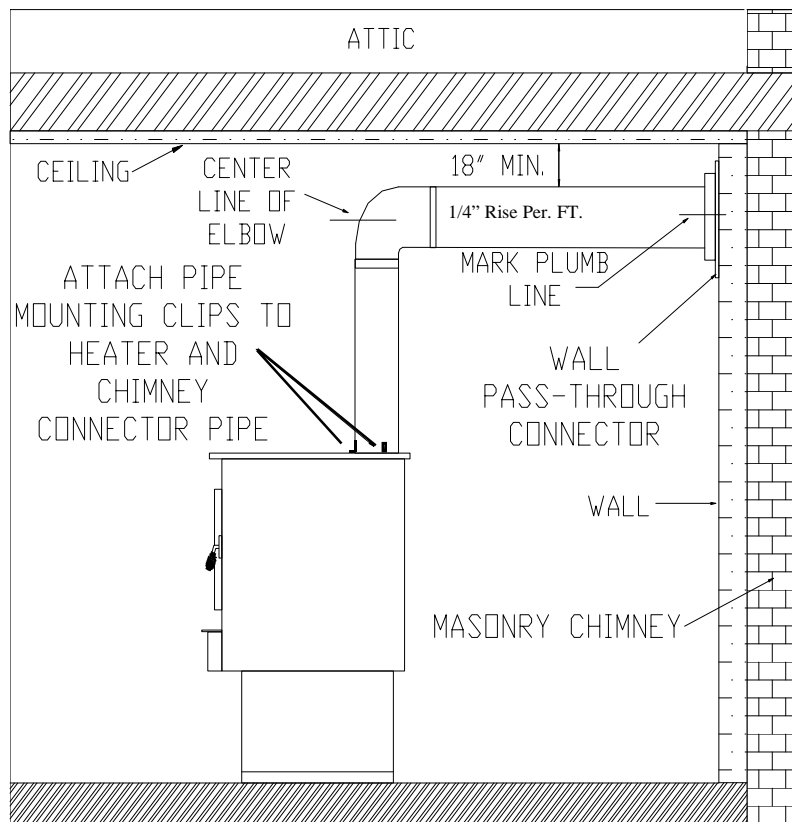

FIGURE 7

thimble meets **NFPA-211** Code and local building codes and is a minimum of 18" from ceiling. If connector thimble does not meet these codes, the pass-through connector must be modified.

Connectors may pass through walls or partitions constructed of combustible material if connector is:

- (a) either listed for wall pass-through or is routed through a device listed for wall pass-through and is installed in accordance with conditions of listing.
- (b) Selected or fabricated in accordance with conditions and clearances as stated in **NFPA 211**-Code. Any unexposed metal that is used as part of a wall pass-through system and is exposed to flue gases shall be constructed of stainless steel or other equivalent material that will resist corrosion, softening, or cracking from flue gases at temperatures up to 1800° F.

In addition, a connector to a masonry chimney shall extend through wall to the inner face or liner but not beyond, and shall be firmly cemented to masonry.

**EXCEPTION:** A thimble may be used to facilitate removal of chimney connector for cleaning, in which case thimble shall be permanently cemented in place with high temperature cement.

2. Once through-the-wall thimble codes are met, simply connect chimney pipe to the wall pass-through connector using #24 ga. minimum blued or black steel pipe as follows:
  - (a) Maintain 1/4" rise per foot (horizontal length) from the appliance to chimney.
  - (b) Each section of pipe should fit into section below or into opening on the stove for drip-free operation.
  - (c) Secure each section to each other using at least three (3) sheet metal screws or rivets.

## Ceiling Exit - Close Clearance

1. Suspend a plumb bob from ceiling above unit so that weight is hanging in the center of flue exit. (A small weight on a string will serve as a plumb bob.) Mark ceiling where string is suspended to locate center of chimney hole.
2. After locating center of hole, install ceiling support box, chimney, flashing and rain cap.
3. Install Double Wall Connector and chimney system per manufacturer's written operating instructions. See manufacturer's list of tested pipes.

**CAUTION:** Because of the high efficiency and low flue gas temperature, freestanding catalytic heaters connected to masonry chimneys with oversized flue liners may encounter drafting problems. A positive flue liner (optional) may be necessary to help draft. A poor drafting chimney may result in poor performance from Model 91. This is not a defect of the Model 91 but a defect in the chimney. This is not a warranty problem with the Model 91. Contact dealer for possible solutions for chimney.

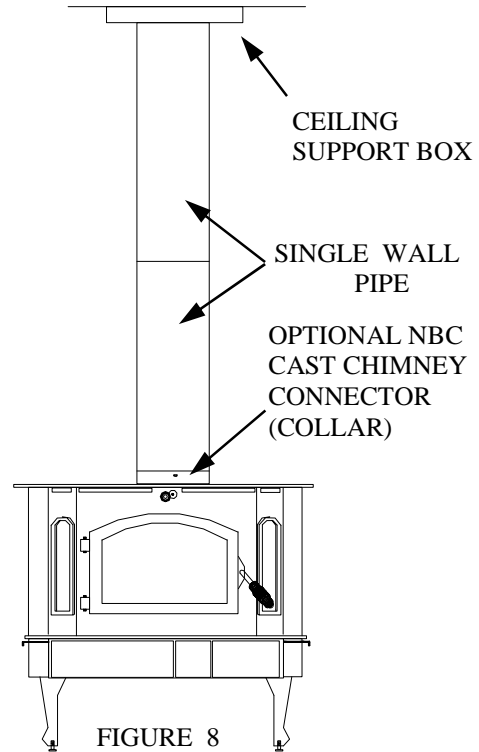

FIGURE 8

Example: The rear clearance for the Model 91 from page 13 is 18". (See Figure 1.) This clearance may be reduced by 50% to 9" by using either of the wall protection devices mentioned below.

## ALTERNATIVES FOR WALL PROTECTION

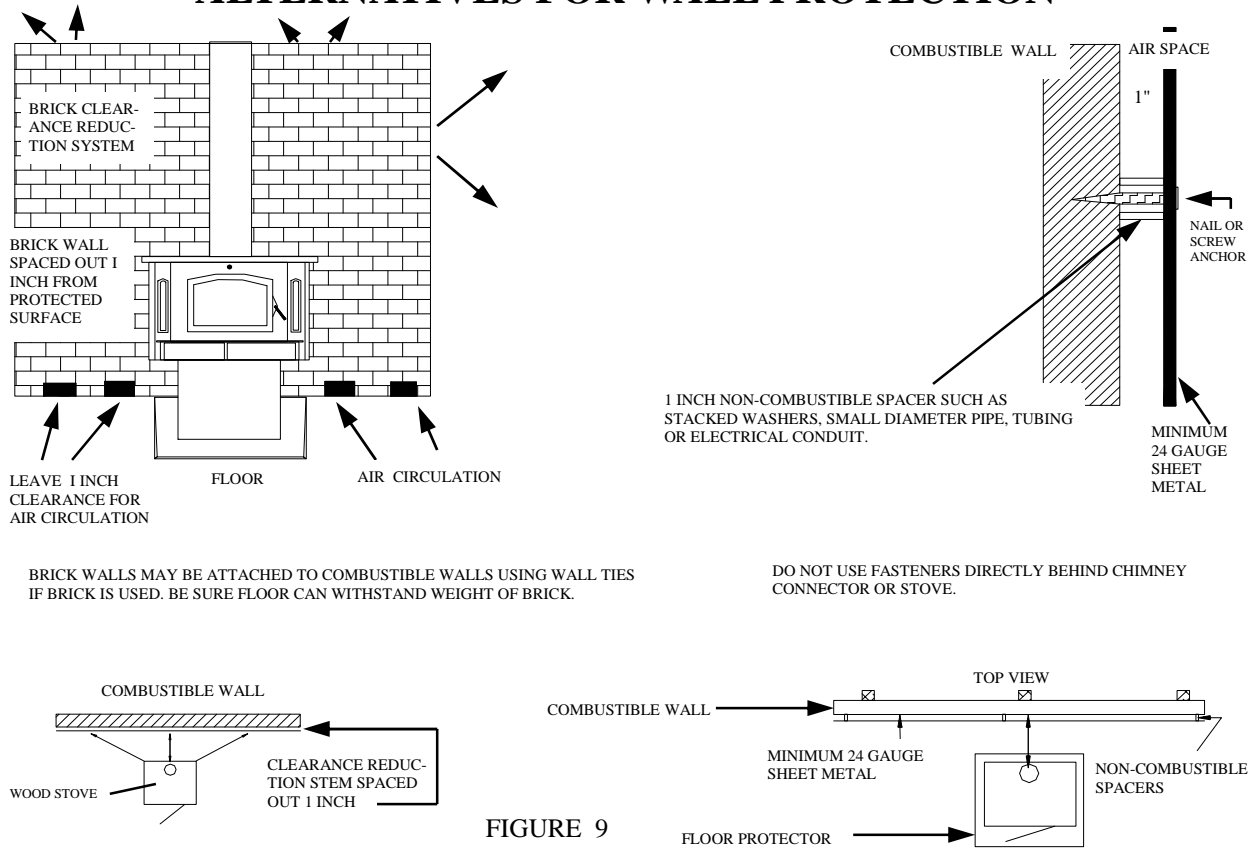

FIGURE 9

### **Tested and Listed Wall Protector**

Clearances to combustibles may be reduced if a tested and listed wall protector is installed over a combustible surface when following conditions exist:

1. A dead air space of 1" separates listed and tested wall protector from combustible surface.
2. The tested and listed wall protector extends from floor to ceiling with a 1" clearance for air circulation at both floor and ceiling.
3. The 1" spacers (preferably ceramic rather than metal) must be located at corners rather than behind heater or chimney connector.

### **Unlisted and Untested Wall Protector**

Wall protectors may be constructed of masonry, 24 gauge or thicker sheet metal, or non-combustible 1/2" thick insulation board. Conditions 2 and 3 above must be observed but, the air space in condition 1 must be increased to 1 1/2".

## **FINAL CHECK**

1. Recheck specified clearances.
2. Remove all foreign material from firebox area.
3. Open primary air draft; shot-gun air draft, and damper bypass. Make sure ash drawer is sealed properly.
4. Plug power cord into a 115V AC outlet. Set switch to "Manual" and rheostat to "High" position to ensure motor operates properly.
5. Place 4 or 5 pieces of newspaper in stove. Light paper and close door. Ensure that stove draws properly through primary drafts.
6. Check for smoke leaks around door.
7. Open door (slowly) and check for smoke escaping from front of stove. Smoking usually indicates a defective or poorly positioned chimney. Some chimneys with a marginal draft can be preheated by lighting newspaper and holding it near open damper with a poker or fire tong. Once chimney heats up, a proper draft can usually be obtained.

**NOTE:** A poor drafting chimney can lead to poor heater performance. This is not a defect of heater, but with the chimney. Poor performance due to a poor drafting chimney is **NOT** a warranty problem.

If a thorough review of Troubleshooting Guide in rear of manual does not solve your problem, contact your dealer for assistance. If homeowner installed unit himself, there generally is a charge for Dealer to service stove and inspect installation.

8. The unit is painted with a specially formulated high temperature paint that cures during the first two or three firings. **DO NOT BUILD A LARGE ROARING FIRE UNTIL THIS CURING IS COMPLETE OR HEATER FINISH MAY BE DAMAGED.** (Paint may blister or peel off. This is not covered by warranty.) You may notice a slight smoking effect and an odor of burning paint when you build the first fires. This is normal and is not a cause for alarm. In some cases these fumes will activate a smoke alarm. Opening a window near unit will allow these fumes to escape.

## SECTION IV

### WOOD HEATER SAFETY

Certain safety hazards are inherent in any wood heater installation. You should be aware of these so that a safe and proper installation can be made.

1. **FAULTY CHIMNEY:** An older masonry chimney should be thoroughly checked to be sure there are no holes or weak spots which could allow sparks or hot gases to escape. If any of these are present, a positive liner should be installed before heater is installed.
2. **HEAT CONDUCTION:** Placing combustible materials too close to a heater or chimney can be a fire hazard.

By keeping these particular hazards in mind as you install and use your room heater you can ensure a safe, reliable installation.

- **NOTE: When burning any unit or appliance that combusts fuel for heat, such as coal, oil, wood or natural and (L.P.) liquid petroleum gas, we highly recommend the use of smoke and carbon monoxide detectors in your home.**

The connector and/or chimney should be inspected at least once a month during heating season to determine if a creosote buildup has occurred. Any buildup of soot should be removed to prevent risk of a chimney fire. To remove chimney or chimney connector, remove screws and/or fasteners. Remove pipe and clean with a steel wire brush. Replace chimney or chimney connector and replace screws and/or fasteners.

**CAUTION:** NEVER use gasoline, gasoline-type lantern fuel, kerosene, charcoal lighter fluid or similar liquids to start or “freshen up” a fire in the heater. Keep all such liquids well away from the stove when it is in use. All fluids of this type give off volatile fumes and can **WILL EXPLODE!!** Don’t take a chance with the safety of your home and family.

**WARNING:** Hot while in operation. Keep children, clothing and furniture away from stove. Contact may cause skin burns.

### HELPFUL HINTS

**CURING THE PAINT ON YOUR HEATER:** During the first several firings, burn small fires to cure paint and to prevent damage to the finish. It is a good idea to flip the toggle switch to “Manual” position during these first firings so the blower will run continuously. This will allow paint to cure at a slower rate and creates a better overall finish.

**CAUTION:** Never remove ashes from your heater with the blower running.

### TIPS ON FIRE BURNING

**GREEN WOOD vs. NATURAL SEASONED HARD WOOD-**Green wood has a high moisture content and therefore requires a hotter ignition temperature. Seasoned wood-cut at least one year before use-allows for a quicker, prolonged burn and more complete combustion.

**SPLIT WOOD vs. ROUND WOOD-**Split wood burns easier and more rapidly, whether it’s seasoned or green. If used after starting a fire, it should be packed tightly to achieve a longer burn.

Round wood burns longer, but requires more effort to start. Inserting a round piece over a bed of red coals with damper and drafts open will help it catch fire. Round wood should be used to accomplish an all-night burn.

# SECTION V

## OPERATION

This section of the manual is to help you get maximum efficiency and maximum smoke (particulate) reduction from your heater. If you should experience any difficulty or have questions concerning your heater, contact your dealer for assistance.

**Manufacturer's recommendation for peak performance and long catalyst life is to burn natural seasoned hardwood (wood dried 6-12 months) and place wood from front to back position in heater.**

**NOTE: Soft woods such as pine, create more creosote, clogging of chimney and produce a less efficient burn performance.**

Build a fire for maximum efficiency. This model burns wood and extracts heat so efficiently, a large fire is not necessary. A large fire not only wastes energy, it usually results in home being too warm for comfort. The following steps will serve as a guide for operating your stove.

### GUIDE TO THE DIFFERENT BURNING QUALITIES OF WOOD

Type of Wood	Ease of Starting	Coaling Qualities	Amount of Sparks
Apple	Poor	Excellent	Few
Ash	Fair	Good	Few
Beech	Poor	Good	Few
Birch	Good	Excellent	Moderate
Cherry	Poor	Excellent	Few
Cedar	Excellent	Poor	Many
Elm	Fair	Good	Very Few
Hemlock	Good	Low	Many
Hickory	Fair	Excellent	Moderate
Locust	Poor	Excellent	Very Few
Maple	Poor	Excellent	Few
Oak	Poor	Excellent	Few
Pine	Excellent	Poor	Moderate

The Main Audubon Society recently charted the heat produced by a wood fire. They noted that heat produced by a wood fire varies greatly with kind of wood burned. Beech is considered best wood for a fire. A cord of well-seasoned Beech will produce as much heat as 169 gallons of fuel oil; Sugar Maple and Red Oak produce as much heat as 166 gallons of fuel oil; followed by White Ash 154; American Elm 130; White Birch 124; and White Pine 94.

## BUILDING A FIRE:

1. Place "Manual/Off/Automatic" switch in "Automatic" (bottom) position for thermostat control operation. Turn rheostat knob clockwise (it will click from "Off" position to "On") so you can vary the speed of motor.
2. Open door.
3. While looking inside firebox, operate damper bypass plate in and out observing movement. This should operate freely and close completely. Open damper bypass.
4. Open air controls on each side of stove (pull out).
5. Twist 4 or 5 pieces of non-colored newspaper in a roll and place on floor of firebox.

The Model 91 Bay is not designed for use with grates, andirons or other methods of supporting the fuel.

**NOTE: "Do not use grate or elevate fire. Build wood fire directly on inner bottom of fire box."**

3. Lay several pieces of dry kindling on top of newspaper.
4. Place three or four small pieces of firewood, 2-3" in diameter, on top of kindling.
5. Light newspaper, close and latch door. Don't leave fire unattended at this point. The draft should start quickly. If not, it may be necessary to preheat the chimney to get draft started. To do this, open door and add newspaper to top rear of the wood. Light or let this paper ignite and allow to burn while holding door slightly open. Do not leave the stove unattended with door open! Once draft has started, close and lock door. A direct connect (option) usually solves this problem. Check with your dealer.
6. After embers and a coal bed have been established, load heater with natural seasoned hard wood, **placing it from front to rear**. DO NOT BUILD A LARGE ROARING FIRE! Initially, build 2-3 small fires in order to cure the paint on your stove.
7. Within 20 minute time frame, you can begin to add your wood. Remember—DO NOT FILL firebox during your first 2 to 3 fires!
8. Once your fire is burning well, **and probe has reached 600°F**, close bypass damper completely (push in). Gradually close primary air controls (push in). You will have to experiment with primary air controls to accommodate your draft. If you close them too soon, your fire may die down too quickly and go out. Close them gradually, a little at a time, until you can close completely.

**NOTE: THE FUELING DOOR MUST REMAIN CLOSED DURING OPERATION.**

**NOTE: Your stove is equipped with a automatic thermostat. When the stove gets hot enough, the thermostat will activate the room air blower. Set fan speed according to desired heat output.**

**NOTE: When refueling or removing ashes turn "OFF" room air blower. Be sure to turn room air blower back on when finished.**

**NOTE: Do not run power cord underneath heater, or in walk way or heavy traffic areas.**

## BURN RATES

- A. **Low Burn Rate:** Set primary air controls (both) almost closed - leave open about 1/8". Set rheostat for fan control between low to medium speed. This burn rate is most desired and most efficient, but can only be achieved after a fire has been established and burning on its own controlled air. Close the bypass damper (push in).
- B. **Medium-Low Burn Rate:** Partially close primary air controls (push halfway in). Close bypass damper (push in). Set the rheostat for fan control halfway between low and high.
- C. **Medium-High Burn Rate:** Set primary air controls almost fully open. Close bypass damper. Set rheostat for fan control between medium position and high position.
- D. **High Burn Rate:** Set primary air controls wide open. Have damper closed. Set rheostat for fan control all way on high. USE CAUTION! Close shotgun air control after 5 minutes.
- E. **Wood Loading:** During refueling, open (pull out) bypass damper to allow smoke in the firebox to escape - wait a few seconds, slowly add wood. Immediately close door and bypass damper. Open primary air control wide open for 2 minutes to charge wood. After most of wood has burned and if you are not planning on reloading immediately, it may be necessary to open damper bypass, then door, and rake wood and coals into a pile near front center of firebox. (Be certain wood chunks are pulled out of rear corners.) Close door and damper bypass. This step will assure continued combustion and thorough burning of wood.

You will have to experiment with fire rate until you find the particular setting for heating your home. Chimney drafts, tightness of house, doors, windows, insulation in house and atmospheric conditions all influence which setting you must have, so it may take several firings to learn setting necessary for your installation. Heating capacity is based on BTU output and conditions listed above. These conditions will affect heating capability of your heater.

Although catalytic stoves decrease ash residue, routine removal of excess ash is still necessary.



## SECTION VI

### PREVENTIVE MAINTENANCE / PARTS REPLACEMENT THE CATALYSTS

The catalysts in your stove are designed for many years of use. If after several years of use, the efficiency of stove decreases or if a notable amount of smoke is observed, catalysts may need to be replaced. See Catalyst Warranty prior to replacement. The following points are some general guidelines from catalyst manufacturer.

1. Do not “hot fire” stove. For many years retailers and installers have advised customers to build an extra hot fire to burn creosote deposits in fire system. This advice may be acceptable for non-cat stoves, but can be death to a catalyst. Why? Because the catalyst is reducing the particulate, or creosote buildup, therefore need to “hot fire” is eliminated. Proper chimney cleaning procedure should be followed.
2. Direct Flame contact is death to a catalyst. A catalyst burns by-products in the smoke. The gases such as CO, HC, and O<sup>2</sup> ignite with each other in a chemical reaction in presence of the catalyst (while passing through the honeycomb configuration). Direct flame inhibits this reaction by changing chemical make-up of catalyst breaking down substrate or ceramic. This problem is called **flame impingement**. Today’s modern stoves are designed so that flame impingement is unlikely. However, a strong, fast draft can pull flame into catalyst. Or, a hot fire, with all air controls and/or the ash door open can literally torch the catalyst. The remedy for hot fire related flame is to advise customers not to “hot fire” stove. The customer will enjoy their catalysts longer and with better performance if these guidelines are followed. Fly ash problems also can be reduced by controlling draft.
3. The **“Glow” Misconception**: A catalyst can glow during certain stages of combustion. The determination that a catalyst is not working simply because it does not glow is inaccurate. During low burn cycle, when catalyst is doing the bulk of its work, it usually does not glow. Also, extremely dry wood (oak, ash, etc.) can burn clean enough not to produce a glow in converter. In most new stoves, you cannot see catalyst.
4. **Light Off Temperature**: CO conversion in the Applied Ceramics catalyst begins at a very low temperature. Usually, a normal start up to produce a coal bed will produce more than sufficient temperatures to begin catalytic combustion.
5. The catalyst is not consumed or “used up”. The nature of a catalytic reaction is defined as follows, by the American Heritage Dictionary, Second College Edition: catalyst “1. Chem. A substance, usually present in small amounts relative to reactants, that modifies and especially increases rate of a chemical reaction without being consumed in process.” This means your catalyst is always there. This also means that gases that would normally go out flue system and pollute the environment are being burned to create more heat from less wood.
6. Why does a catalyst stop working? Most catalyst that are returned are either destroyed by flame impingement, broken due to accidents or mishandling or have nothing wrong with them but fly ash build-up. A catalyst can be “saturated” with by-products of wood burning such as potassium. This is chemical saturation. The prohibitive chemical will fill in the chemical “holes” that gases normally use for reaction. This process of saturation can be slowed by regular maintenance of catalyst. Saturation can take several years since there are units in use for over five years. Burning garbage, painted woods or large amounts of colored paper can poison your unit. Poisoning, however, is very difficult to do. Burning colored paper causes more of a fly ash problem than a risk of poisoning. NEVER BURN RUBBER OR PLASTIC.
7. Burn only dried natural seasoned hard wood. Wood should be dried for at least 12 months prior to burning. The wood should be FREE of any moisture such as RAIN or SNOW. Wet wood creates water vapor which can drop the temperature of catalyst. The results can be plugging, clogging and thermal shock to catalyst. When a catalyst has ceased to be effective, you will notice increased fuel usage and your chimney sweep will notice increased creosote in your system. Before you replace unit, review this section. If you find that your catalyst should be replaced, follow instructions for warranty replacement that were provided when your unit was purchased.

8. Cleaning catalyst with plain water can reduce build-up of catalyst-retarding chemicals. Nothing but a soft brush, low pressure air or plain water should be used to clean a catalyst. The ceramic unit is fragile in comparison to rest of the stove, so it should be handled with care. A soak in warm or hot (not boiling) water for 20 minutes is ideal. Then, allow unit to cool at room temperature and rinse under medium pressure under a faucet. Allow unit to thoroughly dry before reinstalling it or you will damage it. Finally, reinstall unit. A cleaning once every year is sufficient for most users. Clean it when you have your flue system cleaned.

### **CATALYST REPLACEMENT (Off-Season Replacement Recommended)**

1. Spread a drop cloth in front of stove.
2. Open door and clean out any ash.
3. Using penetrating oil, generously lubricate eight (8) bolt threads holding catalyst housing in place. Allow oil to penetrate.
4. Using a 9/16" wrench or 9/16" socket, loosen eight (8) nuts and remove catalyst housing (drop down) and place in a suitable work area. **BE CAREFUL** removing the 8 nuts. If you break bolt, you will have to drill out bolt (difficult) and wait for your dealer to order one! You do not want this to happen during cold weather!
5. Using needle nose pliers, grasp front edge of stainless steel "cans" which houses catalytic element and pull upward. Reposition pliers to another position and pull upward. Repeat procedure until catalyst can be removed from housing.
6. Using a small putty knife or scraper, remove any gasket that may have adhered to catalyst housing.
7. Now, obtain new catalysts and wrap stainless steel "can" with interam gasket and tape ends together using scotch tape or masking tape. **IMPORTANT: BEFORE STARTING TO REPLACE CATALYST, contact your dealer and order INTERAM gasket and CATALYST HOUSING Gasket.** Gaskets not covered under warranty. It may take your dealer several days to receive the gaskets.
8. Insert new catalysts into catalytic housing and push down until they are seated on the top of stainless steel wire mesh supports.
9. Reinstall catalyst housing into stove and secure in place with bolts.
10. The stove is now ready for use.

### **DOOR GASKET REPLACEMENT (Cold Heater)**

To replace deteriorated gaskets, the following steps must be taken to ensure proper installation of gaskets.

1. Obtain proper gaskets and silicone glue from your local dealer.
2. Using pliers, remove any worn and deteriorated gaskets.
3. Using a scraper, wire brush and sandpaper or steel wool, clean glue and gasket residue from door frame.
4. Measure and cut gaskets to length. Care should be taken not to stretch gaskets. What you want is a full and loose gasket weave after attachment to framing.
5. Obtain silicone glue and run a 3/16" bead inside door frame.
6. Obtain gasket (s) and place in gasket channel areas. Use a technique which assures that gasket is applied in a loose like manner. **DO NOT STRETCH GASKETS.**
7. After gasket (s) are applied to glue, use your finger and go over all gasket gently pressing gasket into channel. Use same pressure against gasket so that final result is an evenly applied gasket.
8. Leave door open and allow at least one hour for glue to dry.
9. Once gaskets are checked, heater is ready for use.
10. This should be done annually. Allowing gaskets to deteriorate can cause over-firing and shorten burn time.

## **MOTOR ASSEMBLY REPLACEMENT**

(Motor, Thermostat, Rheostat, Wiring Harness)

1. Unplug heater from 115V AC outlet.
2. To replace motor you must first take cover door off. Do this by removing two screws holding it in place.
3. Next, you will find a wire cage protecting you from electrical components of this unit. By looking to right of ash pan, you will find two screws that hold wire cage in place. Remove two screws. You will also find a screw at bottom right of wire cage. Remove this screw. It will be easier to remove cage if you first take the knob and nut from the rheostat that is hooked to the cage. Lay cage aside.
4. To remove motor simply unhook wire servicing motor. Take two screws holding motor bracket on.
5. Gently slide motor out and while pulling it out moving the rear of motor facing you from right to left in a counterclockwise motion.
6. To replace the thermostat follow steps 1 through 3 and then gently push the thermostat up out of bracket.
7. To rewire motor, rheostat and thermostat see Figures 10.
8. To replace motor turn motor so that 4"x4" air discharge opening is pointing toward rear of stove. The flat part of motor housing is turned up. With the air discharge opening pointing in the 2 o'clock position, start in toward unit rotating rear of motor clockwise. The air discharge opening of motor housing fits in a cavity in rear of unit that will direct air flow to proper location. Make sure air discharge opening is located firmly in opening. Replace motor bracket to motor.
9. Hook up wiring to all three components if you have replaced or unhooked them.
10. Replace rheostat on to screen housing. Fasten screen housing to vertical bar to right of ash pan. Also fasten motor bracket to bar at same time.
11. Replace screw at bottom of screen guard. Replace cover door.
12. Plug heater back into a 115V AC outlet.

# WIRING SCHEMATIC

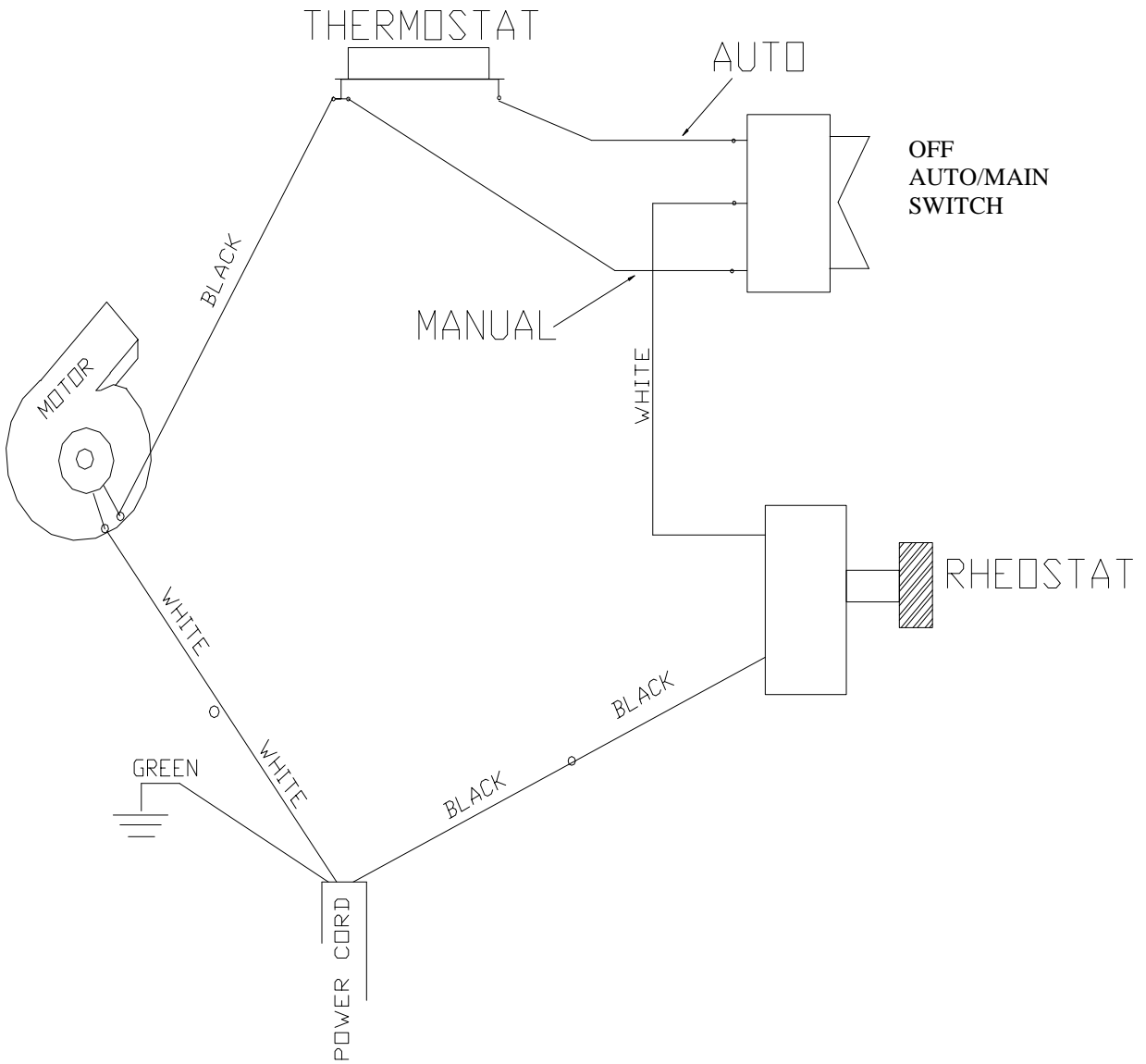

# SECTION VII

## TROUBLESHOOTING

Operation of any wood heater can create problems. While use of a catalytic-combustor equipped stove will substantially lessen some of these problems– such as creosote formation– other traditional wood heater problems may remain.

The following guidelines apply to operation of all wood heaters, with problems related to catalytic heater addressed where appropriate.

### HEATER RELATED PROBLEMS

Problem	Possible Cause	Solution
1. Sluggish Heater Performance	<ol style="list-style-type: none"> <li>1. Obstruction in chimney</li> <li>2. Improperly sealed trim kit or direct connect kit</li> <li>3. Manual damper in chimney is closed</li> <li>4. Closing bypass or exhaust damper too soon</li> <li>5. Poor chimney draft</li> <li>6. Combustor is plugged</li> <li>7. Wet or unseasoned wood being burned</li> </ol>	<ol style="list-style-type: none"> <li>1. Check cap and chimney and remove obstruction.</li> <li>2. Check trim kit gasket or direct connect kit seal to fireplace and gasket as necessary to seal unit. Gasket under stove if needed. Check seal or direct connect and correct</li> <li>3. Open manual damper and wire shut with stainless steel wire or remove damper</li> <li>4. Follow <b>New Buck</b> instructions for proper firing procedures</li> <li>5. Flue may need extension. Oversized flue may need direct connect or positive liner.</li> <li>6. See section in “Combustor Related Problems”</li> <li>7. Burn dry, natural seasoned hard wood</li> </ol>
2. High Fuel Consumption	<ol style="list-style-type: none"> <li>1. Inexperience in catalytic operation</li> <li>2. Improper regulation of draft or inlet air</li> <li>3. Air leaking around door frame and/or glass</li> <li>4. Bypass damper open</li> </ol>	<ol style="list-style-type: none"> <li>1. Operate stove with desired heat output in mind. Do not be overly concerned with maintaining light-off temperatures</li> <li>2. Close inlet air control as much as possible to maintain desired heat output. Check gaskets, reinstall fiberglass gasketing around doors and glass as necessary</li> <li>3. Check door gasket. Check adjustment of door latch.</li> <li>4. Close bypass damper</li> </ol>

3. Backpuffing	<ol style="list-style-type: none"> <li>1. Gusts of wind / windy day</li> <li>2. Hot combustor. (Above 1400° F)</li> </ol>	<ol style="list-style-type: none"> <li>1. If flue cap not on chimney, install one.</li> <li>2. Increase the amount of combustion air slowly</li> </ol>
4. Smoke Rollout when Heater Door is Opened	<ol style="list-style-type: none"> <li>1. Bypass damper is closed</li> <li>2. Opened door too soon after opening bypass damper</li> <li>3. Wind gusts blowing</li> </ol>	<ol style="list-style-type: none"> <li>1. Open bypass damper</li> <li>2. Open bypass damper– wait 15 -30 seconds before slowly opening door</li> <li>3. Install flue cap</li> </ol>
5. Low Catalytic Temperature	<ol style="list-style-type: none"> <li>1. Bypass is open</li> <li>2. Light-off not obtained</li> <li>3. Fuel charge is spend</li> <li>4. Combustor coated with fly ash or soot</li> <li>5. Heater damper down too much</li> </ol>	<ol style="list-style-type: none"> <li>1. Once light-off temperatures have been reached and unit is stabilized, close bypass</li> <li>2. Follow manufacturer’s operating instructions</li> <li>3. Refuel as necessary for combustor operation</li> <li>4. See Section VII “Preventive Maintenance”</li> <li>5. Ensure that proper air mixture and draft are available for wood to burn proper</li> </ol>
<b>COMBUSTOR-RELATED PROBLEMS</b>		
1. Plugging	<ol style="list-style-type: none"> <li>1. Burning materials that produce a lot of char and fly ash</li> <li>2. Burning wet, pitchy wood or burning large loads of small-diameter wood with the combustor in the operating position without light-off taking place</li> </ol>	<ol style="list-style-type: none"> <li>1. Do not burn materials such as garbage, gift wrap or cardboard</li> <li>2. Burn dry, natural seasoned hard wood. Don’t place the combustor in the operating position until high temperatures are high enough to initiate light-off</li> </ol>
2. Catalyst Peeling	<ol style="list-style-type: none"> <li>1. Extreme temperatures at combustor surface can cause the catalyst to peel. Over-firing and flame impingement are primary causes</li> </ol>	<ol style="list-style-type: none"> <li>1. If severe, remove and replace catalysts. See “Catalyst Replacement” Section VI. Avoid extreme temperatures</li> </ol>
3. Catalyst Masking	<ol style="list-style-type: none"> <li>1. Not maintaining light-off temperatures</li> </ol>	<ol style="list-style-type: none"> <li>1. See Section VI and review operating instruction.</li> </ol>

**NEW BUCK CORPORATION (NBC)  
“LIMITED WARRANTY” FOR NBC RELATED PRODUCTS**

**PLEASE READ THIS WARRANTY CAREFULLY  
PRODUCTS COVERED**

This warranty covers heating unit so long as it is owned by original purchaser, including optional and standard accessories purchased at same time, subject to terms, limitations and conditions herein set out.

**PRODUCTS NOT COVERED**

This warranty does not cover the following:  
Glass, Refractory material or firebrick, Gaskets.

This warranty will not cover any damage and/or failure caused by abuse or improper installation of products covered.

**WARRANTY TIME PERIODS**

**(A) Period I**

For one (1) year from date of purchase, NBC will replace or repair, at its option, any part defective in materials or workmanship. The costs of parts only are included. The customer pays any labor or transportation charges required.

**Thereafter**

**(B) Period II**

For period after the first (5) year from the date of purchase and extending for five (5) years as long as related product is owned by original purchaser, NBC will repair or replace, at its option, any part defective in materials or workmanship, with exception of: electrical motors, wiring, switches and components; optional and standard accessories; and all parts not permanently attached to heating unit. Parts not permanently attached to heating unit are defined as those items designed to be removed from unit, including those removable with common hand tools. The cost of parts only are included. The customer pays any labor or transportation charges required.

**PROCEDURE**

Should you feel that your **heater** is defective, you should contact any NBC dealer for name of your nearest authorized heater service representative, who will instruct you on proper procedure, depending on which Warranty Time Period (Period I or Period II) applies.

If for any reason you are dissatisfied with the suggested procedures, you may contact us in writing at:

**NEW BUCK CORPORATION  
Customer Service Department  
P. O. Box 69  
Spruce Pine, NC 28777**

**CONDITIONS AND EXCLUSIONS**

- (A) Replacement of parts may be in form of new or fully reconditioned parts, at NBC's option.
- (B) There are no other warranties express or implied including warranties of Merchantability, Fitness for Purpose or Otherwise except those warranties expressly stated herein.
- (C) **New Buck Corporation** is not liable for indirect, incidental or consequential damages in connection with the use of the product including any cost or expense or providing substitute equipment or service during periods of malfunction or non-use. Some states do not allow exclusion of incidental or consequential damages, so the above exclusion may not apply to you.
- (D) All warranty repairs under this warranty must be performed by an authorized Buck Stove service representative. Repairs or attempted repairs by anyone other than an authorized service representative are not covered under this warranty. In addition, these unauthorized repairs may result in additional malfunctions, correction of which is not covered by warranty.

**OTHER RIGHTS**

This warranty gives you specific legal rights, and you may also have other rights, which vary from state to state.

**OWNER REGISTRATION CARD**

The attached Owner Registration Card must be completed in its entirety and mailed within 30 days from date of purchase or from date of installation, if installed by a factory certified installer, to New Buck Corporation, in order for warranty coverage to begin.

**PLEASE NOTE:** The Owner Registration Card must contain the Authorized Dealer Code Number and the Certified Installer's number (if applicable) for warranty coverage to begin.

To be completed by selling distributor or dealer for customer:

**OWNER REGISTRATION CARD**

Name \_\_\_\_\_  
(Last) (First)

Address \_\_\_\_\_

City \_\_\_\_\_ State \_\_\_\_\_ Zip \_\_\_\_\_

*CUSTOMER EMAIL::* \_\_\_\_\_

Model 91 Bay \_\_\_\_\_ Insert: Residential \_\_\_\_\_

Model 91 Bay \_\_\_\_\_ Freestanding: Residential \_\_\_\_\_

Serial No. \_\_\_\_\_

Date of Installation: Day \_\_\_\_\_ Month \_\_\_\_\_ Year \_\_\_\_\_

Installer's Name \_\_\_\_\_ Certification No. \_\_\_\_\_

Dealer Name \_\_\_\_\_

City \_\_\_\_\_ State \_\_\_\_\_

Dealer No. \_\_\_\_\_

Distributor Name \_\_\_\_\_

Distributor No. \_\_\_\_\_

Is appliance customer self-installed? Yes \_\_\_\_\_ No \_\_\_\_\_

Has appliance been completely checked out? Yes \_\_\_\_\_ No \_\_\_\_\_

Has customer been given appliance and operation orientation? Yes \_\_\_\_\_ No \_\_\_\_\_

- |                                      |   |
|--------------------------------------|---|
| _____ a) Damper/Door Vents           | _____ g) Paint Curing                                     |
| _____ b) Door-Handle/ Removing       | _____ h) Chimney Safety                                   |
| _____ c) Thermostat-Normal Operation | _____ i) Rain Cap   |
| _____ d) Hot Surface Area            | _____ j) Wood Preparation                                 |
| _____ e) Speed Control (Rheostat)    | _____ k) Installation                                     |
| _____ f) Switch—Manual/Off/Auto      | _____ l) Instructions & Clearances -<br>Self-Installation |

Has customer been given **WARRANTY REVIEW**? Yes \_\_\_\_\_ No \_\_\_\_\_

CUSTOMER SIGNATURE \_\_\_\_\_

New Buck Review

DATE \_\_\_\_\_

Mail to:

**NEW BUCK CORPORATION**  
P.O. Box 69  
200 Ethan Allen Dr.  
Spruce Pine, NC 28777





**Obadiiah's**

**1-800-968-8604**

---

**WOODSTOVES**

*Serving you online since 1999*