

INSTALLER: LEAVE THIS MANUAL WITH THE APPLIANCE.
CONSUMER: RETAIN THIS MANUAL FOR FUTURE REFERENCE.
NEVER LEAVE CHILDREN OR OTHER AT RISK INDIVIDUALS ALONE WITH THE APPLIANCE.



INSTALLATION AND OPERATING INSTRUCTIONS

CERTIFIED UNDER AMERICAN NATIONAL STANDARDS: ANSI Z21.11.2 FOR UNVENTED ROOM HEATERS.

WHVF31N NATURAL GAS

WHVF31P PROPANE

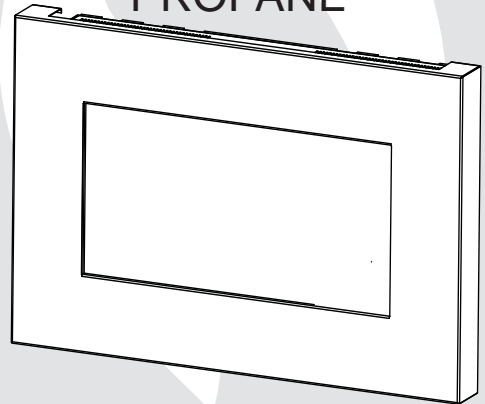

CERTIFIED FOR THE UNITED STATES USING ANSI METHODS.

SAFETY INFORMATION

WARNING

If the information in these instructions are not followed exactly, a fire or explosion may result causing property damage, personal injury or loss of life.

- Do not store or use gasoline or other flammable vapors and liquids in the vicinity of this or any other appliance.
- WHAT TO DO IF YOU SMELL GAS:
 - Do not try to light any appliance.
 - Do not touch any electrical switch; do not use any phone in your building.
 - Immediately call your gas supplier from a neighbour's phone. Follow the gas supplier's instructions.
 - If you cannot reach your gas supplier, call the fire department.
- Installation and service must be performed by a qualified installer, service agency or the supplier.
- This is an unvented gas-fired heater that uses air (oxygen) from the room in which it is installed. Provisions for adequate combustion and ventilation air must be provided. Refer to section "COMBUSTION AND VENTILATION AIR PROVISIONS".

This appliance may be installed in an aftermarket, permanently located, manufactured (mobile) home, where not prohibited by local codes. This appliance is only for use with the type of gas indicated on the rating plate. This appliance is not convertible for use with other gases.

WARNING

HOT GLASS WILL CAUSE BURNS.

DO NOT TOUCH GLASS UNTIL COOLED.

NEVER ALLOW CHILDREN TO TOUCH GLASS.



Wolf Steel Ltd., 24 Napoleon Rd., Barrie, ON, L4M 0G8 Canada /
103 Miller Drive, Crittenden, Kentucky, USA, 41030

Phone (705)721-1212 • Fax (705)722-6031 • www.napoleonfireplaces.com • ask@napoleonproducts.com

TABLE OF CONTENTS

1.0	INSTALLATION OVERVIEW	3
2.0	INTRODUCTION	4
2.1	DIMENSIONS	5
2.1.1	CONVEX SURROUND (S31CV)	5
2.1.2	RECTANGULAR SURROUND (S31R)	5
2.2	GENERAL INSTRUCTIONS	5
2.3	GENERAL INFORMATION	7
2.4	RATING PLATE INFORMATION	7
3.0	INSTALLATION	8
3.1	COMBUSTION AND VENTILATION AIR PROVISIONS	8
3.2	DETERMINING CONFINED OR UNCONFINED SPACE	8
3.3	MOUNTING PLATE INSTALLATION	10
3.4	MOUNTING THE APPLIANCE	10
3.5	GAS INSTALLATION	11
3.6	MOBILE HOME	11
3.7	MINIMUM CLEARANCE TO COMBUSTIBLES	12
4.0	FINISHING	13
4.1	HOUSING PANEL INSTALLATION	13
4.2	DOOR REMOVAL / INSTALLATION	14
4.3	BRICK PANEL INSTALLATION	14
4.4	GLASS MEDIA	15
4.5	SURROUND INSTALLATION / REMOVAL	15
5.0	OPTIONAL INSTALLATION	16
5.1	SAFETY SCREEN INSTALLATION	16
5.2	REMOTE RECEIVER LOCATION/WIRING	16
6.0	ELECTRICAL INFORMATION	17
6.1	WIRING DIAGRAM	17
7.0	OPERATION	18
7.1	LIGHTING AND OPERATING INSTRUCTIONS	18
8.0	ADJUSTMENTS	19
8.1	VENTURI ADJUSTMENT	19
8.2	FLAME CHARACTERISTICS	19
9.0	MAINTENANCE	20
9.1	CARE OF GLASS	20
9.2	CARE OF PLATED PARTS	20
9.3	DOOR GLASS REPLACEMENT	21
9.4	PILOT REPLACEMENT	21
10.0	REPLACEMENTS	22
11.0	TROUBLE SHOOTING	24
12.0	WARRANTY	26
13.0	SERVICE HISTORY	27

NOTE: Changes, other than editorial, are denoted by a line in the margin.

1.0 INSTALLATION OVERVIEW

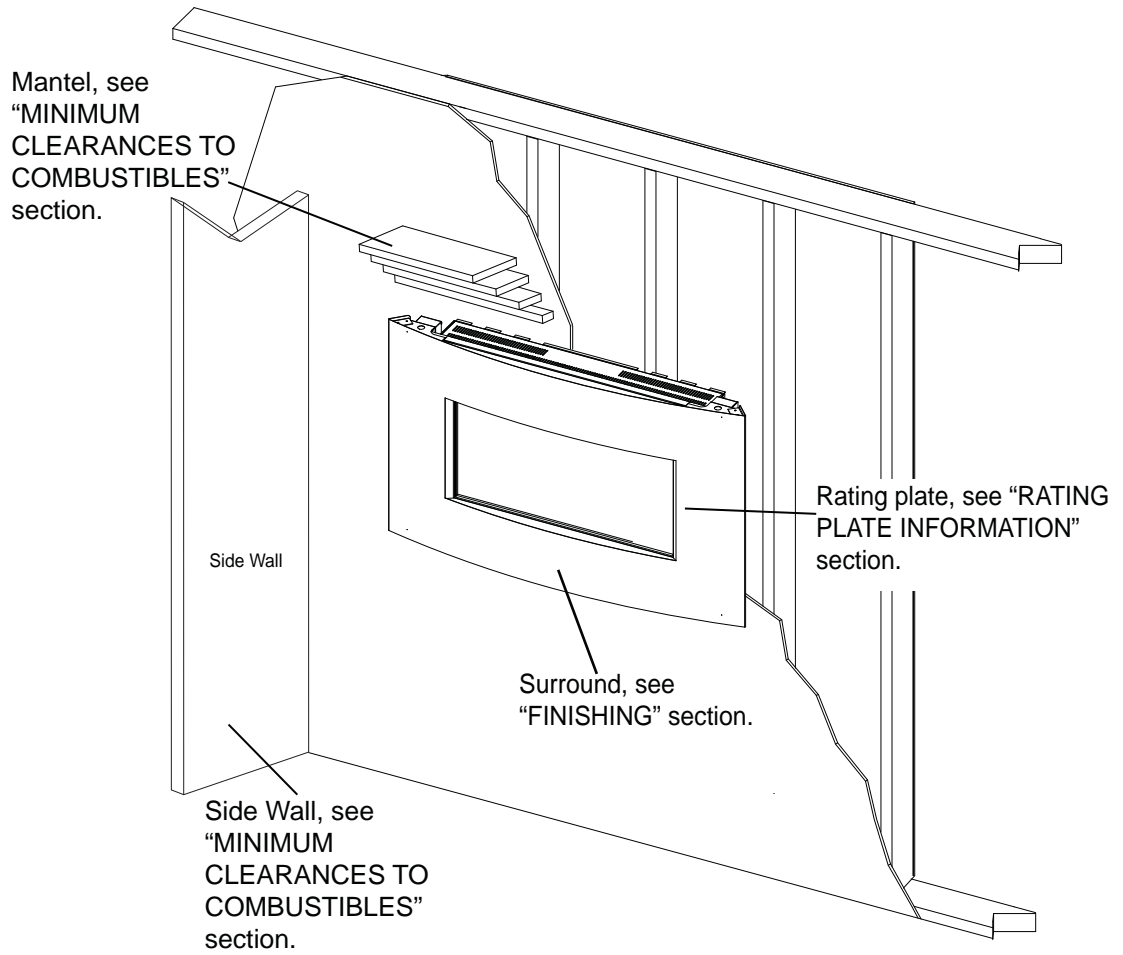

2.0 INTRODUCTION

WARNING

- **THIS APPLIANCE IS HOT WHEN OPERATED AND CAN CAUSE SEVERE BURNS IF CONTACTED.**
- **ANY CHANGES TO THIS APPLIANCE OR ITS CONTROLS CAN BE DANGEROUS AND IS PROHIBITED.**
- Under no circumstances should this appliance be modified.
- Do not operate appliance before reading and understanding operating instructions. Failure to operate appliance according to operating instructions could cause fire or injury.
- Risk of burns. The appliance should be turned off and cooled before servicing.
- Do not install damaged, incomplete or substitute components.
- Risk of cuts and abrasions. Wear protective gloves and safety glasses during installation. Sheet metal edges may be sharp.
- Provide adequate ventilation and combustion air. Provide adequate accessibility clearance for servicing and operating the appliance. Never obstruct the front opening of the appliance.
- If the appliance shuts off, do not re-light until you provide fresh air. If appliance keeps shutting off, have it serviced. Keep burner and control compartment clean.
- Do not burn wood or other materials in this appliance.
- Children and adults should be alerted to the hazards of high surface temperature and should stay away to avoid burns or clothing ignition.
- Young children should be carefully supervised when they are in the same room as the appliance. Toddlers, young children and others may be susceptible to accidental contact burns. A physical barrier is recommended if there are at risk individuals in the house. To restrict access to an appliance, install an adjustable safety gate to keep toddlers, young children and other at risk individuals out of the room and away from hot surfaces.
- Due to high temperatures, the appliance should be located out of traffic and away from furniture and draperies.
- Ensure you have incorporated adequate safety measures to protect infants/toddlers from touching hot surfaces.
- Clothing or other flammable material should not be placed on or near the appliance.
- Check with your local hearth specialty dealer for safety screens and hearth guards to protect children from hot surfaces. These screens and guards must be fastened to the floor.
- Any safety screen or guard removed for servicing must be replaced prior to operating the appliance.
- It is imperative that the control compartments, burners and circulating blower and its passageway in the appliance are kept clean. The appliance should be inspected before use and at least annually by a qualified service person. More frequent cleaning may be required due to excessive lint from carpeting, bedding material, etc. The appliance area must be kept clear and free from combustible materials, gasoline and other flammable vapours and liquids.
- Furniture or other objects must be kept a minimum of 4 feet away from the front of the appliance.
- Do not use this appliance if any part has been under water. Immediately call a qualified service technician to inspect the appliance and to replace any part of the control system and any gas control which has been under water.
- Do not allow fans to blow directly into the appliance. Avoid any drafts that alter burner flame patterns.
- Do not use a blower insert, heat exchanger insert or other accessory not approved for use with this appliance.
- Carbon or soot should not occur in a vent free appliance as it can distribute into the living area of your home. If you notice any signs of carbon or soot, immediately turn off your appliance and arrange to have it serviced by a qualified technician before operating it again.
- Keep the packaging material out of reach of children and dispose of the material in a safe manner. As with all plastic bags, these are not toys and should be kept away from children and infants.
- As with any combustion appliance, we recommend having your appliance regularly inspected and serviced as well as having a Carbon Monoxide Detector installed in the same area to defend you and your family against Carbon Monoxide.
- If equipped, the screen must be in place (closed) when the appliance is in operation.
- Ensure clearances to combustibles are maintained when building a mantel or shelves above the appliance. Elevated temperatures on the wall or in the air above the appliance can cause melting, discolouration or damage to decorations, a T.V. or other electronic components.

3.4B

2.1 DIMENSIONS

2.1.1 CONVEX SURROUND (S31CV)

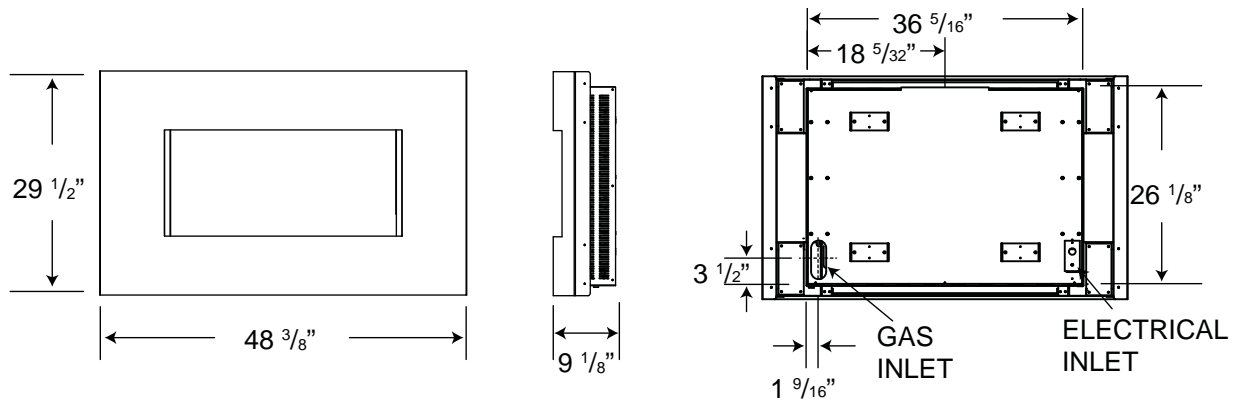

2.1.2 RECTANGULAR SURROUND (S31R)

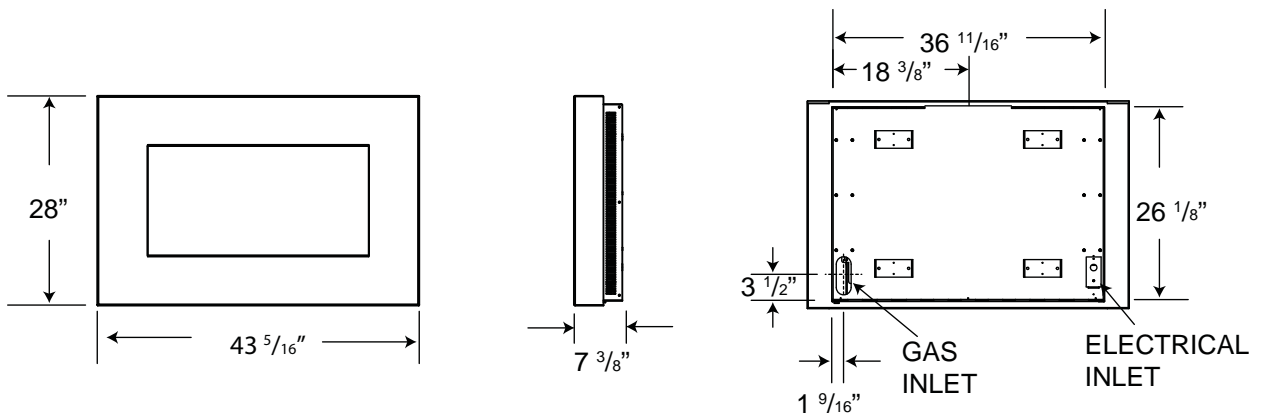

2.2 GENERAL INSTRUCTIONS

! WARNING

*** CARBON MONOXIDE POISONING MAY LEAD TO DEATH**
EARLY SIGNS OF CARBON MONOXIDE POISONING RESEMBLE THE FLU, WITH HEADACHE, DIZZINESS AND/OR NAUSEA. IF YOU HAVE THESE SIGNS, THE HEATER MAY NOT BE WORKING PROPERLY. GET FRESH AIR AT ONCE! HAVE HEATER SERVICED.
SOME PEOPLE---PREGNANT WOMEN, PERSONS WITH HEART OR LUNG DISEASE, ANEMIA, THOSE UNDER THE INFLUENCE OF ALCOHOL, THOSE AT HIGH ALTITUDES--- ARE MORE AFFECTED BY CARBON MONOXIDE THAN OTHERS.

THE APPLIANCE IS ONLY FOR USE WITH THE TYPE OF GAS INDICATED ON THE RATING PLATE. THIS APPLIANCE IS NOT CONVERTIBLE FOR USE WITH OTHER GASES.

OBJECTS PLACED IN FRONT OF THE HEATER SHOULD BE KEPT A MINIMUM OF 48" AWAY FROM THE FRONT FACE OF THE APPLIANCE.

USE ONLY WOLF STEEL APPROVED OPTIONAL ACCESSORIES AND REPLACEMENT PARTS WITH THIS APPLIANCE. USING NON-LISTED ACCESSORIES AND REPLACEMENT PARTS (BLOWERS, LOUVRES, TRIMS, GAS COMPONENTS, VENT COMPONENTS, ETC.) COULD RESULT IN A SAFETY HAZARD AND WILL VOID THE LIMITED LIFETIME WARRANTY.

THIS APPLIANCE MUST NOT BE INSTALLED IN A BEDROOM OR BATHROOM.

DO NOT OPERATE WITHOUT CERAMIC CATALYST IN PLACE.

This gas appliance should be installed and serviced by a qualified installer to conform with local codes. Installation practices vary from region to region and it is important to know the specifics that apply to your area, for example: in Massachusetts State:

- The appliance off valve must be a "T" handle gas cock.
- The flexible connector must not be longer than 36".
- The appliance is not approved for installation in a bedroom or bathroom unless the appliance is a direct vent sealed combustion product.
- A carbon monoxide detector is required in all rooms containing gas fired appliances.
- **WARNING:** This product must be installed by a licensed plumber or gas fitter when installed within the commonwealth of Massachusetts.
- Un-vented room appliance shall be installed in accordance with 527 CMR 30.00 and 248 CMR 3.00 through 7.00.
- Sellers of un-vented propane or natural gas-fired space / room appliances shall provide to each purchaser a copy of 527 CMR 30.00 upon the sale of the appliance from http://www.napoleonfireplaces.com/Webshare/installation_manuals/mass_requirements.pdf

In absence of local codes, install the appliance to the current National Fuel Gas Code, ANSI Z223.1 Installation Code which can be obtained from:

American National Standards Institute Inc.

1430 Broadway
New York, NY 10018

or

National Fire Protection Association Inc.

Batterymarch Park
Quincy, MA 02269

The appliance and its individual shutoff valve must be disconnected from the gas supply piping system during any pressure testing of that system at test pressures in excess of 1/2 psig (3.5 kPa). The appliance must be isolated from the gas supply piping system by closing its individual manual shutoff valve during any pressure testing of the gas supply piping system at test pressures equal to or less than 1/2 psig (3.5 kPa). When installed with a blower the junction box must be electrically connected and grounded in accordance with local codes. In the absence of local codes, use the current ANSI / NFPA 70 National Electric Code. In the case where the blower is equipped with a power cord it must be connected into a properly grounded receptacle. The grounding prong must not be removed from the cord plug.

As long as the required clearance to combustibles is maintained, the most desirable and beneficial location for the appliance is in the center of a building, thereby allowing the most efficient use of the heat created. The location of windows, doors and the traffic flow in the room where the appliance is to be located should be considered.

* Air shortage caused by an inadequate air supply, improper log positions, the addition of foreign or unapproved materials or the failure to properly maintain the appliance, may result in incomplete combustion of the fuel. Incomplete combustion results in soot being deposited inside the firebox as well as surfaces outside the appliance. If any soot deposits are observed, shut off the appliance immediately and arrange for it to be serviced by a qualified technician. Incomplete combustion can also generate increased levels of carbon monoxide (CO).



4.10A

2.3 GENERAL INFORMATION

FOR YOUR SATISFACTION, THIS APPLIANCE HAS BEEN TEST-FIRED TO ASSURE ITS OPERATION AND QUALITY!

RATES AND EFFICIENCIES		
	NATURAL GAS	PROPANE GAS
Altitude	0 - 2,000*	0 - 2,000*
Maximum Input	20,000 BTU/hr	20,000 BTU/hr
Efficiency	99.9%	99.9%
Minimum Inlet Gas Supply Pressure	4.5" Water Column	11" Water Column
Maximum Inlet Gas Supply Pressure	7" Water Column	13" Water Column
Manifold Pressure Under Flow Conditions	3.5" Water Column	10" Water Column

* When the appliance is installed at elevations above 2,000ft, and in the absence of specific recommendations from the local authority having jurisdiction, the certified high altitude input rating shall be reduced at the rate of 4% for each additional 1,000ft.

This appliance is suitable for mobile home installation. The natural gas model can only be installed in a mobile home that is permanently positioned on its site and fueled with natural gas. This appliance may be installed in an aftermarket permanently located, manufactured (mobile) home, where not prohibited by local codes.

This appliance is only for use with the type of gas indicated on the rating plate. This appliance is not convertible for use with other gases.

The appliance is equipped with two catalytic tiles which are designed to filter out harmful gases and limit carbon monoxide output. It is likely that with the appliance in operation, the catalytic tiles will actually scrub the carbon monoxide normally found in the room and reduce it to a lower level. The tiles must not be altered or removed. Do not operate the appliances when using products such as paint, paint thinner, adhesives, etc. These products will permanently affect the catalytic tiles' ability to scrub the air.

Expansion / contraction noises during heating up and cooling down cycles are normal and are to be expected.

2.4 RATING PLATE INFORMATION

For rating plate location, see "INSTALLATION OVERVIEW" section.

This illustration is for reference only. Refer to the rating plate on the appliance for accurate information.

CERTIFIED UNDER: ANSI Z21.11A-2010 UNVENTED ROOM HEATER
 THIS APPLIANCE SHALL NOT BE INSTALLED IN A BEDROOM OR BATHROOM, AND IS INTENDED FOR SUPPLEMENTAL HEATING. THIS APPLIANCE MAY BE INSTALLED IN AN AFTERMARKET, PERMANENTLY LOCATED, MANUFACTURED (MOBILE) HOME, WHERE NOT PROHIBITED BY LOCAL CODES. THIS APPLIANCE IS ONLY FOR USE WITH THE TYPE OF GAS INDICATED ON THE RATING PLATE. THIS APPLIANCE IS NOT FIELD CONVERTIBLE FOR USE WITH OTHER GASES. THIS IS A GAS-FIRED UNVENTED ROOM HEATER THAT REQUIRES ADEQUATE COMBUSTION AND VENTILATION AIR.

ETL
 Intertek
 9700539 (WSL)
 4001657 (NGZ)
 4001658 (NAC)
 4001659 (WUSA)

WHVF31N CWHVF31N CWHVF31P WHVF31P

NATURAL GAS MODEL	PROPANE MODEL
0-2000FT	0-2000FT
20,000 BTU/HR	20,000BTU/HR
SIT 880 (NG)	SIT 880 (LP)
OP 426000	OP 608000

ALTIMUDE **CONTROL**
PILOT

*ABOVE 2,000FT, CONSULT LOCAL AUTHORITY HAVING JURISDICTION.

MANIFOLD PRESSURE: 3.6"	MANIFOLD PRESSURE: 10"
WATER COLUMN (NG)	WATER COLUMN (LP)
MIN. SUPPLY PRESSURE: 4.5"	MIN. SUPPLY PRESSURE: 11"
WATER COLUMN (NG)	WATER COLUMN (LP)
MAX. SUPPLY PRESSURE: 7"	MAX. SUPPLY PRESSURE: 13"
WATER COLUMN (NG)	WATER COLUMN (LP)

NOT FOR USE WITH SOLID FUEL

CAUTION: FOR USE WITH GLASS DOORS CERTIFIED WITH THIS UNIT ONLY.

WARNING: DO NOT ADD ANY MATERIAL TO THE APPLIANCE, WHICH WILL COME IN CONTACT WITH THE FLAME. DO NOT USE ACCESSORIES NOT APPROVED FOR USE WITH THIS APPLIANCE. APPLY LOOSE MATERIAL PER INSTRUCTIONS MANUAL. DO NOT APPLY EXTRA MATERIAL OR MATERIAL NOT SUPPLIED WITH THE APPLIANCE. IMPROPER INSTALLATION, ADJUSTMENT, ALTERNATION, SERVICE OR MAINTENANCE CAN CAUSE PROPERTY DAMAGE, PERSONAL INJURY OR LOSS OF LIFE. REFER TO THE OWNER'S INFORMATION MANUAL PROVIDED WITH THIS APPLIANCE. INSTALLATION AND SERVICE MUST BE PERFORMED BY A QUALIFIED INSTALLER, SERVICE AGENCY OR THE GAS SUPPLIER.

ELECTRICAL RATING: 115V.60HZ. LESS THAN 12 AMPERES

MINIMUM CLEARANCE TO COMBUSTIBLE MATERIAL (FROM APPLIANCE):
 MANTEL 20"
 FLOOR 13"
 SIDES 7"

WOLF STEEL LTD.
 24 NAPOLEON ROAD, BARRIE, ON, L4M 0G8 CANADA

SERIAL NUMBER WHVF31

W385-0613 / A

3.0 INSTALLATION

3.1 COMBUSTION AND VENTILATION AIR PROVISIONS

This appliance shall not be installed in a confined space or unusually tight construction unless provisions are provided for adequate combustion and ventilation air.

The National Fuel Gas Code, ANSI Z223.1 / NFPA 54 defines a confined space as a space whose volume is less than 50 cubic feet per 1,000 Btu per hour (4.8 m³ per kw) of the aggregate input rating of all appliances installed in that space and an unconfined space as a space whose volume is not less than 50 cubic feet per 1,000 Btu per hour (4.8 m³ per kw) of the aggregate input rating of all appliances installed in that space. Rooms communicating directly with the space in which the appliances are installed, through openings not furnished with doors are considered a part of the unconfined space.

17.1A

The WHVF31 is rated at 20,000 BTUs per hour for natural gas and propane and therefore requires a minimum unconfined space of 1000 cubic feet.

3.2 DETERMINING CONFINED OR UNCONFINED SPACE

To determine the volume of the room where the appliance is to be installed, multiply the width x the length x the ceiling height of that room measured in feet. If any adjoining rooms are connected by grilles or openings such as kitchen pass-throughs, etc., the volume of those rooms may be added to the total.

Multiply the room volume by 1000 and divide this amount by 50 to determine the maximum BTU/hr that the space can support with adequate combustion and ventilation air.

Add the Btu/hr of all fuel burning appliances located within the space such as gas furnace, gas water appliance, etc. Do not include direct vent gas appliances which draw their input and output air from and to the outdoors.

WARNING

IF THE AREA IN WHICH THE APPLIANCE MAY BE OPERATED IS SMALLER THAN THAT DEFINED AS AN UNCONFINED SPACE OR IF THE BUILDING IS OF UNUSUALLY TIGHT CONSTRUCTION, PROVIDE ADEQUATE COMBUSTION AND VENTILATION AIR BY ONE OF THE METHODS DESCRIBED IN THE NATIONAL FUEL GAS CODE ANSI Z223.1/ NFPA 54 , AIR FOR COMBUSTION AND VENTILATION, OR THE APPLICABLE LOCAL CODE.

IF THE AREA IN WHICH THE APPLIANCE MAY BE OPERATED DOES NOT MEET THE REQUIRED VOLUME FOR INDOOR COMBUSTION AIR, COMBUSTION AND VENTILATION AIR SHALL BE PROVIDED BY ONE OF THE METHODS DESCRIBED IN THE ANSI Z223.1 / NFPA 54, THE INTERNATIONAL FUEL GAS CODE, OR APPLICABLE LOCAL CODES.

Unusually tight construction is defined as construction where:

- A) Walls and ceilings exposed to the outside atmosphere have a continuous water vapour retarder with a rating of 1 perm (6 x 10⁻¹¹ kg per pa-sec-m²) or less with openings gasketed or sealed, and
- B) Weather stripping has been added on openable windows and doors, and
- C) Caulking or sealants are applied to areas such as joints around window and door frames, between sole plates and floors, between wall-ceiling joints, between wall panels, at penetrations for plumbing, electrical, and gas lines, and at other openings.

An unvented room appliance is recommended for use as a secondary heat source rather than as a primary source. Gas combustion produces water vapour which could occur at the rate of approximately one ounce of water for every 1,000 BTU/hr of gas input. During the cold weather season, indoor humidity levels tend to be low. Consequently, this water vapour can enhance the living space. However if a problem should occur:

- A) Ensure sufficient combustion and circulation air
- B) Use a dehumidifier
- C) Do not use the unvented room appliance as a primary heat source

Without sufficient fresh air for proper operation, poor fuel combustion can result. Carbon Monoxide is a result of poor combustion.

If additional fresh air is required, use one of the methods described in the National Fuel Gas Code, ANSI Z223.1 / NFPA54 or the applicable local code.

Room Volume = Length x Width x Height

Max BTU/hr = Room Volume x 1000 / 50

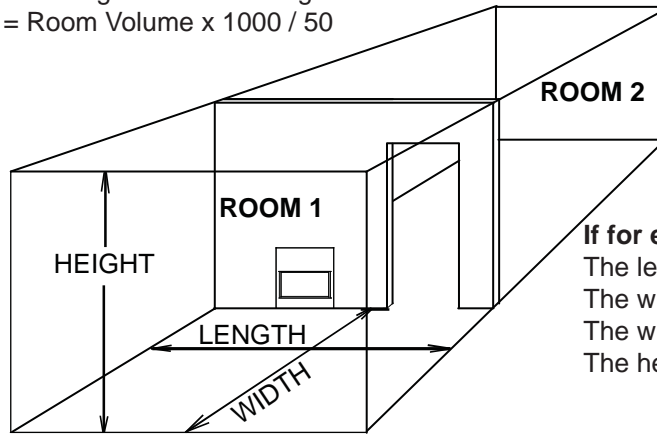

If for example:

The length of the rooms is 10 feet,
The width of Room 1 is 10 feet,
The width of Room 2 is 15 feet,
The height of the rooms is 8 feet.

The volume of Room 1: $10 \times 10 \times 8 = 800$ cubic feet
The volume of Room 2: $10 \times 15 \times 8 = 1200$ cubic feet

19.1B

EXAMPLE 1:

In this example, because there is no door to the adjoining room, the volume of the adjoining room may be added to the volume of the room with the heater to get a total unconfined space.

The total unconfined space: $800 + 1200 = 2000$ cubic feet.

Maximum BTU/h: $\frac{2000 \times 1000}{50} = 40,000$ BTU/h

19.2

EXAMPLE 2:

If in this example a solid door separates Room 1 from Room 2, the volume of Room 2 could not be used. In this case the maximum BTU/h would be:

Maximum BTU/h: $\frac{800 \times 1000}{50} = 16,000$ BTU/h

19.3

This would be considered a confined space since it can not support the 20,000 BTU/h input of the appliance and it would be necessary to provide adequate combustion and ventilation air to Room 1.

3.3 MOUNTING PLATE INSTALLATION

- A. Level and affix the paper template to the wall at desired location and height. The centre line of the template should be located directly between two wall studs.
- B. Using the template, mark the holes for the gas and electrical outlets and mounting screws. See "MINIMUM CLEARANCES TO COMBUSTIBLES" section. **NOTE: There are two sets of four mounting holes. Choose the appropriate set for either 16" or 24" centres and make sure they line up to the wooden wall studs. If this is not possible, mark the template where the studs are located and transfer these locations to the mounting plate.**
- C. Remove the paper template from the wall and cut the holes as marked.
- D. Remove the four screws that secure the wall mounting plate to the appliance.
- E. If required, transfer the stud location marks from the template to the mounting plate and drill a $\frac{1}{4}$ diameter hole. Level the mounting plate and secure it to the studs using the 4 fasteners provided. The fasteners must be threaded into the wall studs.

3.4 MOUNTING THE APPLIANCE

- A. Secure the appliance to the mounting plate as illustrated using 8 screws provided.

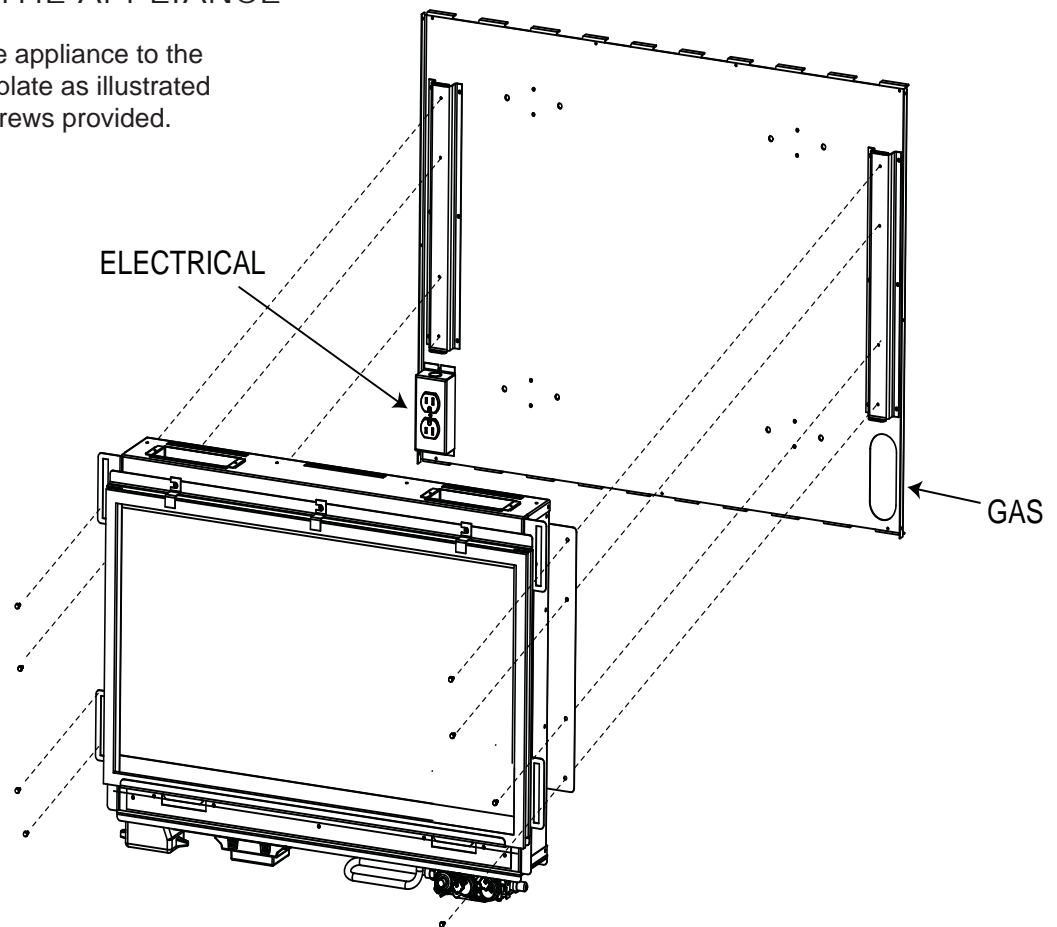

3.5 GAS INSTALLATION

 WARNING
RISK OF FIRE, EXPLOSION OR ASPHYXIATION. ENSURE THERE ARE NO IGNITION SOURCES SUCH AS SPARKS OR OPEN FLAMES.
SUPPORT GAS CONTROL WHEN ATTACHING GAS SUPPLY PIPE TO PREVENT DAMAGING GAS LINE.
ALWAYS LIGHT THE PILOT WHETHER FOR THE FIRST TIME OR IF THE GAS SUPPLY HAS RUN OUT WITH THE GLASS DOOR OPENED OR REMOVED. PURGING OF THE GAS SUPPLY LINE SHOULD BE PERFORMED BY A QUALIFIED SERVICE TECHNICIAN. ASSURE THAT A CONTINUOUS GAS FLOW IS AT THE BURNER BEFORE CLOSING THE DOOR. ENSURE ADEQUATE VENTILATION. FOR GAS AND ELECTRICAL LOCATIONS, SEE “DIMENSION” SECTION.
ALL GAS CONNECTIONS MUST BE CONTAINED WITHIN THE APPLIANCE WHEN COMPLETE.
HIGH PRESSURE WILL DAMAGE VALVE. DISCONNECT GAS SUPPLY PIPING BEFORE TESTING GAS LINE AT TEST PRESSURES ABOVE 1/2 PSIG.
VALVE SETTINGS HAVE BEEN FACTORY SET, DO NOT CHANGE.

Installation and servicing to be done by a qualified installer.

- A. Move the appliance into position and secure.
- B. If equipped with a flex connector the appliance is designed to accept a 1/2" gas supply. Without the connector it is designed to accept a 3/8" gas supply. The appliance is equipped with a manual shut off valve to turn off the gas supply to the appliance.
- C. Connect the gas supply in accordance to local codes. In the absence of local codes, install to the current CAN/CSA-B149.1 Installation Code in Canada or to the current National Fuel Gas Code, ANSI Z223.1 / NFPA 54 in the United States.
- D. When flexing any gas line, support the gas valve so that the lines are not bent or kinked.
- E. The gas line flex-connector should be installed to provide sufficient movement for shifting the burner assembly on it's side to aid with servicing components.
- F. Check for gas leaks by brushing on a soap and water solution. **Do not use open flame.**

30.1A

3.6 MOBILE HOME

Suitable for mobile home installation where the mobile home has been permanently placed on its site.

This appliance may be installed in an aftermarket permanently located, manufactured (mobile) home, where not prohibited by local codes.

For mobile home installations, the appliance must be fastened in place. It is recommended that the appliance be secured in all installations. See “REPLACEMENTS” section for the levelling / securing kit specific to your appliance.

29.2

3.7 MINIMUM CLEARANCE TO COMBUSTIBLES

The front trims for the WHVF31 are different sizes. See "DIMENSIONS" section prior to mounting the appliance. Clearances are measured from the appliance, not the front trims.

MINIMUM CLEARANCES TO COMBUSTIBLES:

- 20" to top
- 7" to sides
- 13" to bottom
- 0" to rear

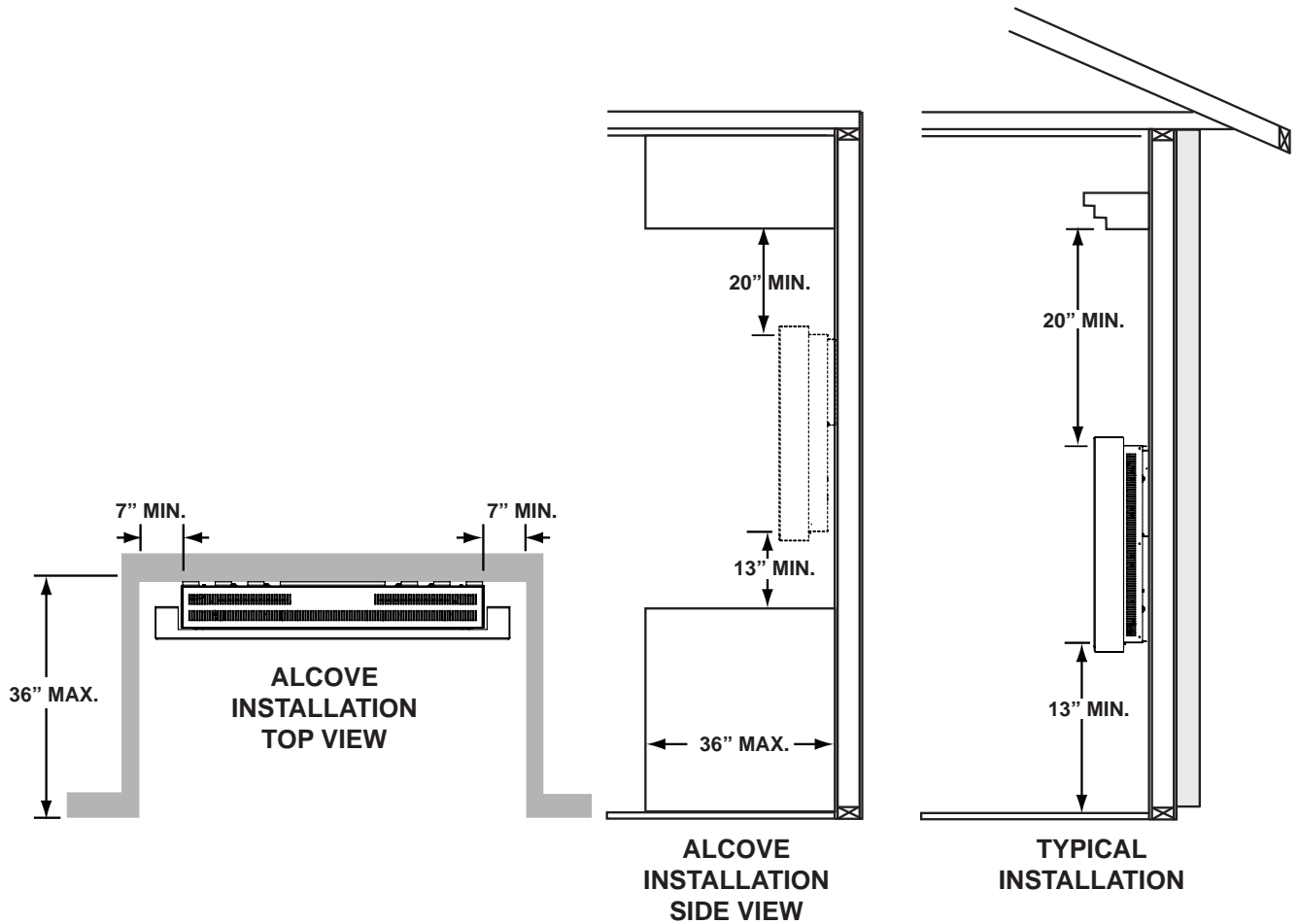

4.0 FINISHING

! WARNING**RISK OF FIRE!****NEVER OBSTRUCT THE FRONT OPENING OF THE APPLIANCE.****DO NOT STRIKE, SLAM OR SCRATCH GLASS. DO NOT OPERATE APPLIANCE WITH GLASS REMOVED, CRACKED, BROKEN OR SCRATCHED.**

72.4

4.1 HOUSING PANEL INSTALLATION

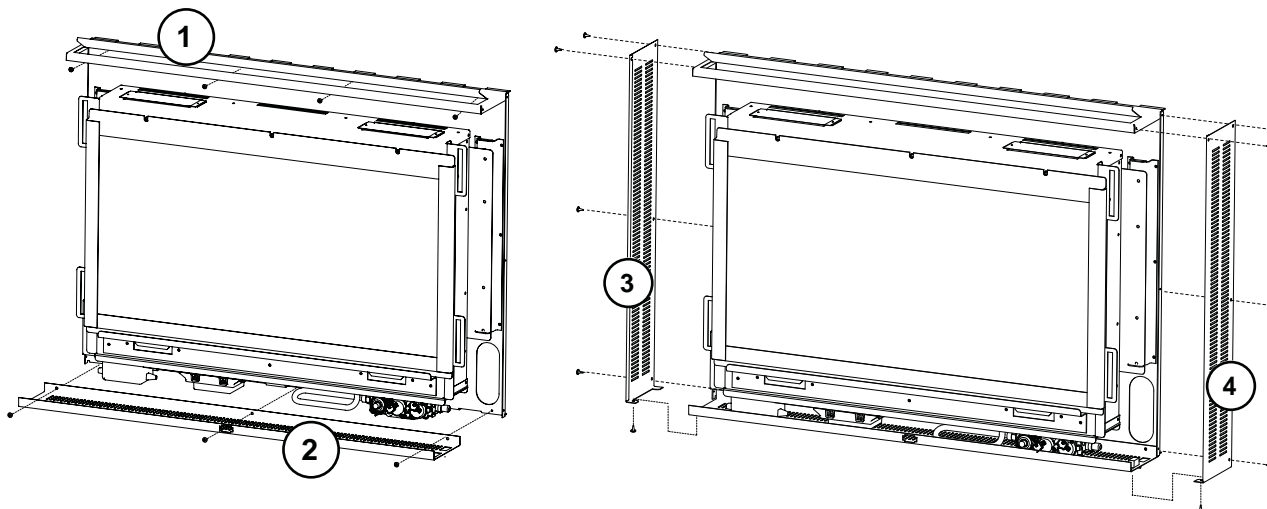

Secure the housing panels as illustrated using the 17 #8 X 3/8" screws supplied.

- 4 screws secure the top housing panel.
- 3 screws secure the bottom housing panel.
- 5 screws secure each of the side housing panels.

4.2 DOOR REMOVAL / INSTALLATION

! WARNING

GLASS MAY BE HOT, DO NOT TOUCH GLASS UNTIL COOLED.

THE DOOR LATCHES ARE PART OF A SAFETY SYSTEM AND MUST BE PROPERLY ENGAGED. DO NOT OPERATE THE APPLIANCE WITH LATCHES DISENGAGED.

FACING AND/OR FINISHING MATERIALS MUST NOT INTERFERE WITH AIR FLOW THROUGH AIR OPENINGS, LOUVRES OPENINGS, OPERATION OF LOUVRES OR DOORS OR ACCESS FOR SERVICE. OBSERVE ALL CLEARANCES WHEN APPLYING COMBUSTIBLE MATERIALS.

BEFORE DOOR IS REMOVED TURN THE APPLIANCE OFF AND WAIT UNTIL APPLIANCE IS COOL TO THE TOUCH. DOORS ARE HEAVY AND FRAGILE SO HANDLE WITH CARE.

75.1

- A. Remove the surround. (see "SURROUND INSTALLATION/REMOVAL" section.)
- B. Remove the 3 screws that secure the door.
- C. Lift the door up and off.

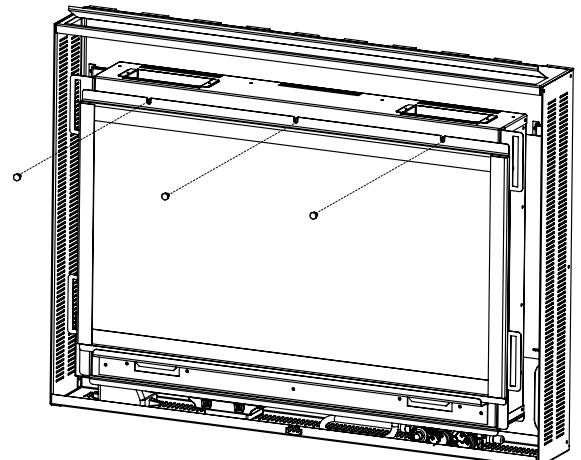

4.3 BRICK PANEL INSTALLATION

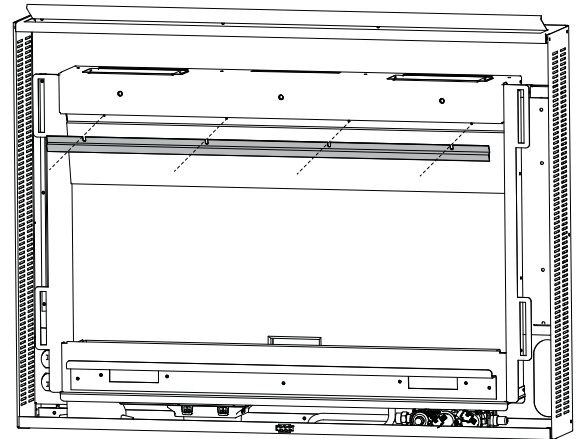
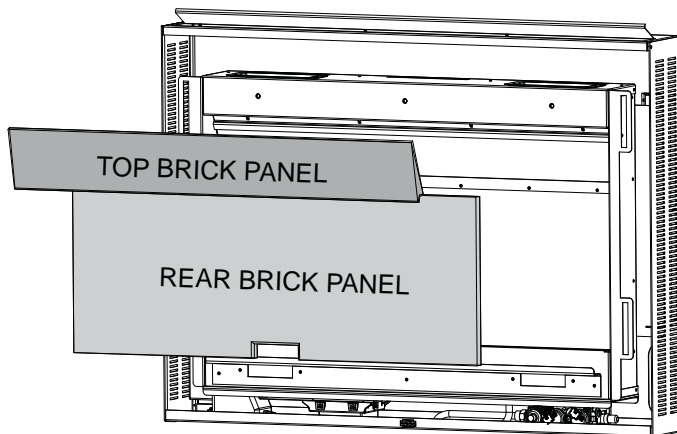

- A. Remove the surround and door if installed. (See "SURROUND INSTALLATION / REMOVAL" and "DOOR REMOVAL / INSTALLATION" sections.)
- B. Centre the rear brick panel against the back of the firebox with the bottom edge resting on the back flange.
- C. Place the top brick panel against the top of the rear brick panel. Align the holes in the brick retainer with the holes in the firebox and secure using the 4 screws provided.

! WARNING

CLEAN THE GLASS MEDIA PRIOR TO INSTALLATION. BEFORE APPLYING THE CLEANED GLASS, ENSURE THAT IT IS DRY.

DO NOT CHANGE OR SUBSTITUTE THE GLASS MEDIA MATERIAL PROVIDED WITH THIS APPLIANCE. IF REPLACING, USE ONLY THE REPLACEMENT GLASS MEDIA AVAILABLE FROM YOUR AUTHORIZED DEALER / DISTRIBUTOR.

GLASS MEDIA OVER THE BURNER MUST NOT BE MORE THAN ONE LAYER HIGH. MORE THAN ONE LAYER OVER THE BURNER WILL CAUSE FLAME LIFTING AND SOOTING PROBLEMS.

Evenly spread the glass media onto the media tray, covering the burner tube and following the natural shape of the media tray.

In some installations, glass media over the burner tube may cause a “Puffing” sound. If this sound is excessive, simply push the media away from the burner ports.

NOTE: The distribution of glass media over the burner tube will influence the flame height. When the flames impinge on the glass, the glass may discolour slightly and the edges may soften.

CLEANING GLASS MEDIA

Glass media may have a fine oil residue that needs to be cleaned prior to installation. Clean the glass with mild dish soap, drain, rinse thoroughly and dry before placing over the burner.

74.1A

4.5 SURROUND INSTALLATION / REMOVAL

- A.** Lift the surround and engage the hooks into the slots on the appliance, then let it slide down into position.

NOTE: When installing the surround ensure no wires are pinched or exposed.

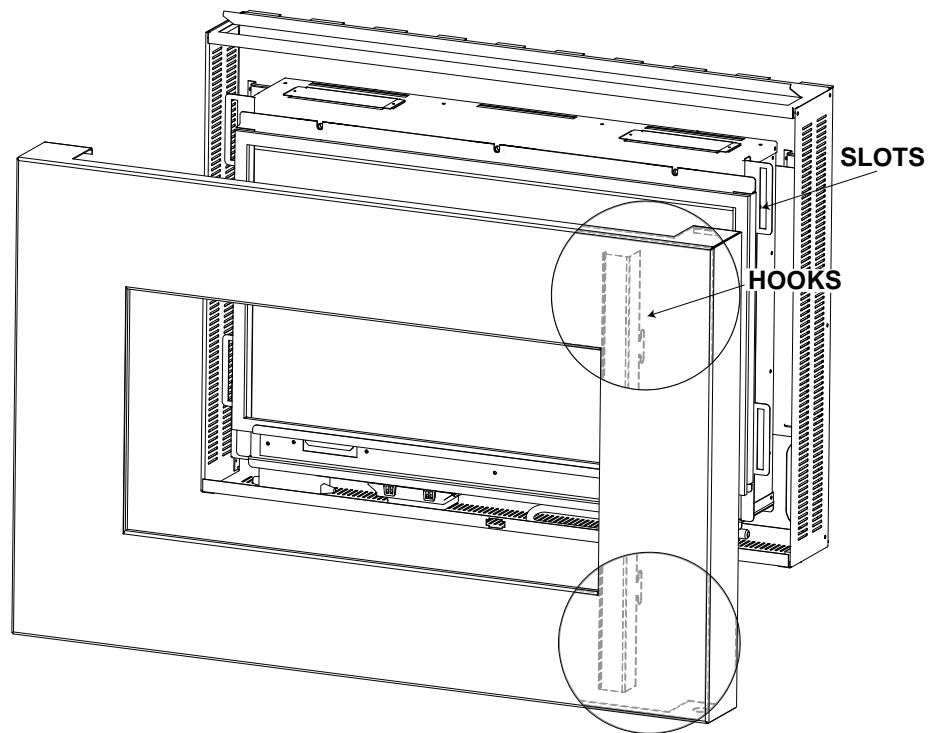

5.0 OPTIONAL INSTALLATION

5.1 SAFETY SCREEN INSTALLATION

- A. Remove the 3 screws that secure the door.
- B. Place the bottom of the safety screen into the door retainer. Pivot the top of the safety screen to the door frame and secure by using 3 screws to attach the safety screen and door retainer brackets.

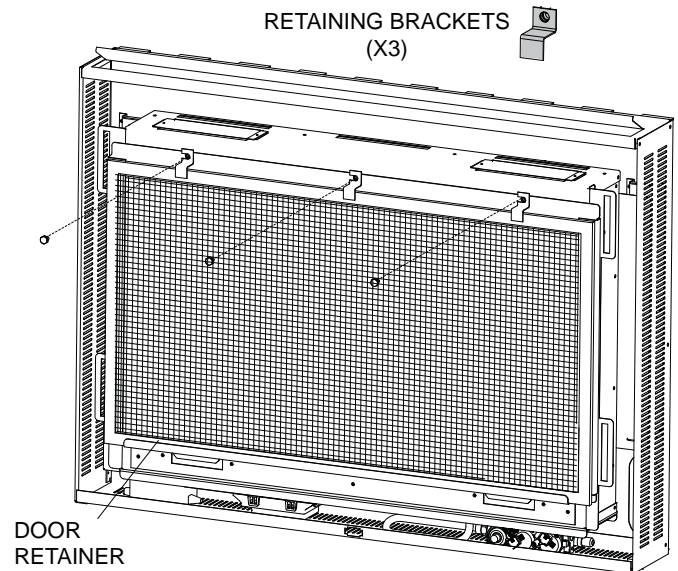

5.2 REMOTE RECEIVER LOCATION/WIRING

If installing an optional remote control, the receiver must be located as illustrated.

- A. Place the receiver against the bottom housing panel as close to the IPI control as possible. Secure using the velcro provided.
- B. For wiring information see the section "WIRING DIAGRAM".

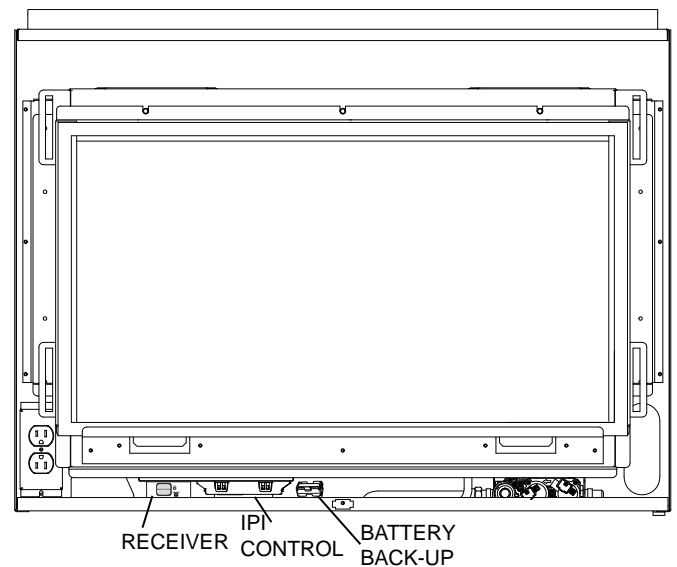

6.0 ELECTRICAL INFORMATION

6.1 WIRING DIAGRAM

! WARNING

DO NOT WIRE 110 VOLTS TO THE VALVE OR WALL SWITCH.

IF ANY OF THE ORIGINAL WIRE AS SUPPLIED WITH THE APPLIANCE MUST BE REPLACED, IT MUST BE REPLACED WITH A WIRE OF AT LEAST A TEMPERATURE RATING.

This appliance comes equipped with a battery back-up. If this backup is used install four AA batteries (not supplied) into the holder and connect to the wire harness. Place near the IPI board. Connect the battery holder to the wire harness before using the appliance. Place near the IPI board. (Batteries not included). If backup is used, it must be connected to the 6 volt battery pack supplied.

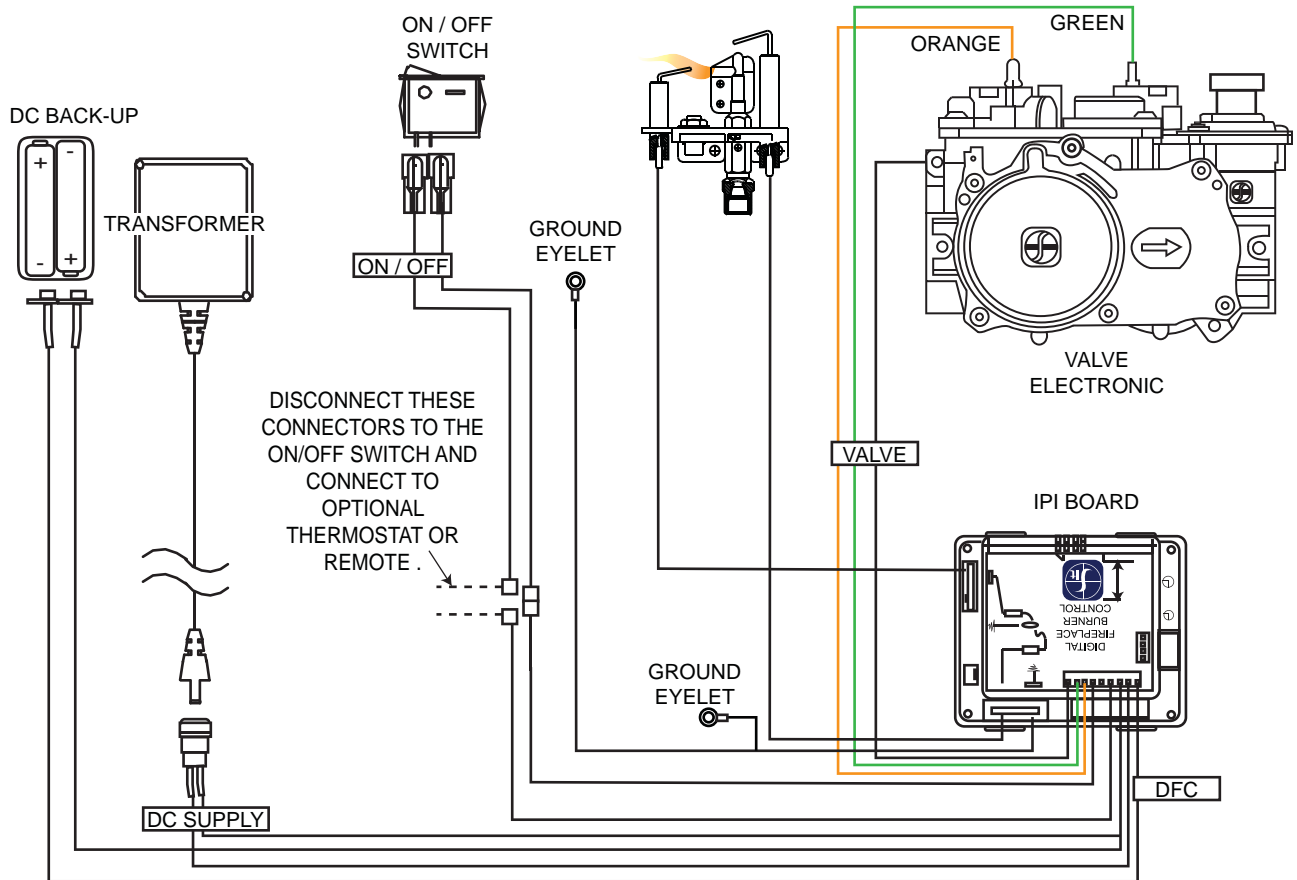



7.0 OPERATION

When lit for the first time, the appliance will emit a slight odour for a few hours. This is a normal temporary condition caused by the “burn-in” of internal paints and lubricants used in the manufacturing process and will not occur again. Simply open a window to sufficiently ventilate the room. After extended periods of non-operation such as following a vacation or a warm weather season, the appliance may emit a slight odour for a few hours. This is caused by dust particles in the heat exchanger burning off. Open a window to sufficiently ventilate the room.

7.1 LIGHTING AND OPERATING INSTRUCTIONS

FOR YOUR SAFETY READ BEFORE OPERATING LIGHTING INSTRUCTIONS

1. STOP! READ ALL INFORMATION OF OPERATING AND LIGHTING INSTRUCTIONS BEFORE PROCEEDING.
 2. TURN OFF ELECTRIC POWER TO THE FIREPLACE.
 3. THIS FIREPLACE IS EQUIPPED WITH AN IGNITION DEVICE WHICH AUTOMATICALLY LIGHTS THE PILOT. DO NOT TRY TO LIGHT THE PILOT BY HAND.
 4. OPEN THE GLASS DOOR.
 5. TURN MANUAL SHUTOFF VALVE CLOCKWISE  TO OFF.
 6. WAIT FIVE (5) MINUTES TO CLEAR OUT ANY GAS. IF YOU SMELL GAS INCLUDING NEAR THE FLOOR, STOP! FOLLOW “B” OF THE OPERATING INSTRUCTIONS. IF YOU DON'T SMELL GAS GO TO THE NEXT STEP.
 7. TURN MANUAL SHUTOFF VALVE COUNTER-CLOCKWISE  TO ON.
 8. CLOSE THE GLASS DOOR.
 9. TURN ON ALL ELECTRIC POWER TO THE FIREPLACE.
 10. TURN ON MAIN BURNER.
- IF THE APPLIANCE WILL NOT OPERATE, FOLLOW THE INSTRUCTIONS “TO TURN OFF GAS” AND CALL YOUR SERVICE TECHNICIAN OR GAS SUPPLIER.

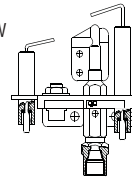

OPERATING INSTRUCTIONS

WARNING: IF YOU DO NOT FOLLOW THESE INSTRUCTIONS EXACTLY, A FIRE OR EXPLOSION MAY RESULT CAUSING PROPERTY DAMAGE, PERSONAL INJURY OR LOSS OF LIFE.

INITIAL LIGHTING OF THE PILOT AND MAIN BURNERS MUST BE DONE WITH THE GLASS DOOR OFF.

DO NOT CONNECT VALVE OR WALL SWITCH TO ELECTRICITY.

SEE INSTALLATION INSTRUCTIONS.

- A. THIS FIREPLACE IS EQUIPPED WITH AN IGNITION DEVICE WHICH AUTOMATICALLY LIGHTS THE PILOT. DO NOT TRY TO LIGHT BY HAND.
- B. BEFORE OPERATING SMELL ALL AROUND THE FIREPLACE AREA FOR GAS AND NEXT TO THE FLOOR BECAUSE SOME GAS IS HEAVIER THAN AIR AND WILL SETTLE ON THE FLOOR.

WHAT TO DO IF YOU SMELL GAS:

- TURN OFF ALL GAS TO THE FIREPLACE.
 - OPEN WINDOWS.
 - DO NOT TRY TO LIGHT ANY APPLIANCE.
 - DO NOT TOUCH ANY ELECTRIC SWITCH; DO NOT USE ANY PHONE IN YOUR BUILDING.
 - IMMEDIATELY CALL YOUR GAS SUPPLIER FROM A NEIGHBOUR'S PHONE. FOLLOW THE GAS SUPPLIER'S INSTRUCTIONS.
 - IF YOU CANNOT REACH YOUR GAS SUPPLIER, CALL THE FIRE DEPARTMENT.
- C. DO NOT TRY TO REPAIR ANY PART OF THIS ASSEMBLY. CALL A QUALIFIED SERVICE TECHNICIAN. FORCE OR ATTEMPTED REPAIR MAY RESULT IN A FIRE OR EXPLOSION.
 - D. DO NOT USE THIS FIREPLACE IF ANY PART HAS BEEN UNDER WATER. IMMEDIATELY CALL A QUALIFIED SERVICE TECHNICIAN TO INSPECT THE FIREPLACE AND REPLACE ANY PART OF THE CONTROL SYSTEM AND ANY GAS CONTROL WHICH HAS BEEN UNDER WATER.

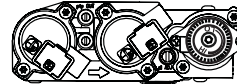

TO TURN OFF GAS

1. TURN OFF ALL ELECTRICAL POWER TO THE FIREPLACE IF SERVICE IS TO BE PERFORMED.
2. TURN MANUAL SHUTOFF VALVE CLOCKWISE  TO OFF. DO NOT FORCE.

W385-0613 / A

8.0 ADJUSTMENTS

8.1 VENTURI ADJUSTMENT

This appliance has an air shutter that has been factory set open according to the chart below:

Regardless of venturi orientation, closing the air shutter will cause a more yellow flame, but can lead to carboning. Opening the air shutter will cause a more blue flame, but can cause flame lifting from the burner ports. The flame may not appear yellow immediately; allow 15 to 30 minutes for the final flame colour to be established.

AIR SHUTTER ADJUSTMENT MUST ONLY BE DONE BY A QUALIFIED INSTALLER!

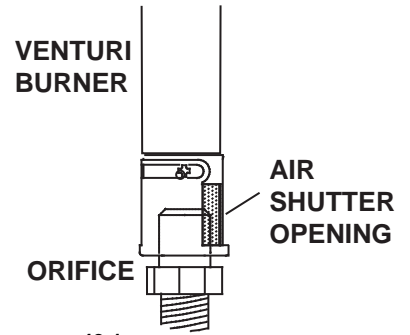

VENTURI ADJUSTMENT CHART	
FUEL	WHVF31
NG	1/16"
LP	1/16"

8.2 FLAME CHARACTERISTICS

It's important to periodically perform a visual check of the pilot and burner flames. Compare them to the illustrations provided. If any flames appear abnormal call a service person.

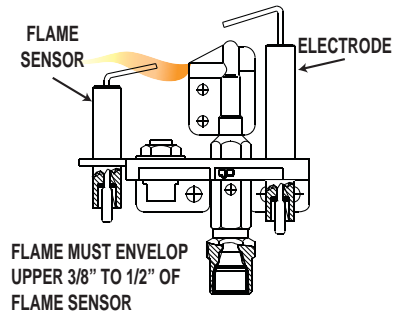
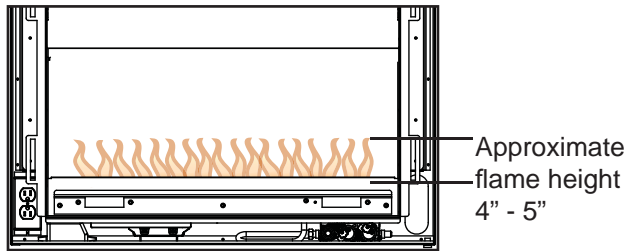

9.0 MAINTENANCE

! WARNING
TURN OFF THE GAS AND ELECTRICAL POWER BEFORE SERVICING THE APPLIANCE.
APPLIANCE MAY BE HOT, DO NOT SERVICE UNTIL APPLIANCE HAS COOLED.
DO NOT USE ABRASIVE CLEANERS.

CAUTION: Label all wires prior to disconnection when servicing controls. Wiring errors can cause improper and dangerous operation. Verify proper operation after servicing. This appliance and its venting system should be inspected before use and at least annually by a qualified service person. The appliance area must be kept clear and free of combustible materials, gasoline or other flammable vapors and liquids. The flow of combustion and ventilation air must not be obstructed.

- In order to properly clean the burner and pilot assembly, remove the logs, rocks and/or glass to expose both assemblies.
 - Keep the control compartment, media, burner, air shutter opening and the area surrounding the logs clean by vacuuming or brushing, at least once a year.
 - Check to see that all burner ports are burning. Clean out any of the ports which may not be burning or are not burning properly.
 - Check to see that the pilot flame is large enough to engulf the flame sensor and/or thermocouple / thermopile as well as reaches the burner.
 - Replace the cleaned logs, rocks or glass. Failure to properly position the media may cause carboning which can be distributed in the surrounding living area.
 - Check to see that the main burner ignites completely on all openings when turned on. A 5 to 10 second total light-up period is satisfactory. If ignition takes longer, consult your local authorized dealer / distributor.
-
- 40.16
- Check that the gasketing on the sides, top and bottom of the door is not broken or missing. Replace if necessary.
 - Blow or vacuum any dust or debris from the catalyst cells, ensuring they are all free from obstruction.

9.1 CARE OF GLASS

DO NOT CLEAN GLASS WHEN HOT! DO NOT USE ABRASIVE CLEANERS TO CLEAN GLASS.

Buff lightly with a clean dry soft cloth. Clean both sides of the glass after the first 10 hours of operation with a recommended fireplace glass cleaner. Thereafter clean as required. If the glass is not kept clean permanent discoloration and / or blemishes may result.

! WARNING	
	<p>HOT GLASS WILL CAUSE BURNS.</p> <p>DO NOT TOUCH GLASS UNTIL COOLED.</p> <p>NEVER ALLOW CHILDREN TO TOUCH GLASS.</p>

5.1

9.2 CARE OF PLATED PARTS

If the appliance is equipped with plated parts, you must clean fingerprints or other marks from the plated surfaces before operating the appliance for the first time. Use a glass cleaner or vinegar and towel to clean. If not cleaned properly before operating for the first time, the marks can cause permanent blemishes on the plating. After the plating is cured, the fingerprints and oils will not affect the finish and little maintenance is required, just wipe clean as needed. Prolonged high temperature burning with the door ajar may cause discoloration on plated parts.

NOTE: The protective wrap on plated parts is best removed when the assembly is at room temperature but this can be improved if the assembly is warmed, using a hair dryer or similar heat source.

6.1

9.3 DOOR GLASS REPLACEMENT

! WARNING
DO NOT USE SUBSTITUTE MATERIALS.
GLASS MAY BE HOT, DO NOT TOUCH GLASS UNTIL COOLED.
CARE MUST BE TAKEN WHEN REMOVING AND DISPOSING OF ANY BROKEN DOOR GLASS OR DAMAGED COMPONENTS. BE SURE TO VACUUM UP ANY BROKEN GLASS FROM INSIDE THE APPLIANCE BEFORE OPERATION.
DO NOT STRIKE, SLAM OR SCRATCH GLASS. DO NOT OPERATE APPLIANCE WITH GLASS REMOVED, CRACKED, BROKEN OR SCRATCHED.

- A. Place the door frame face down careful not to scratch the paint.
- B. Center the gasketed glass inside the door frame with the thick side of the gasket facing up.
- C. Bend the glass retainers located along the edge of the door frame over the gasket holding the glass in place. Careful not to break the glass.

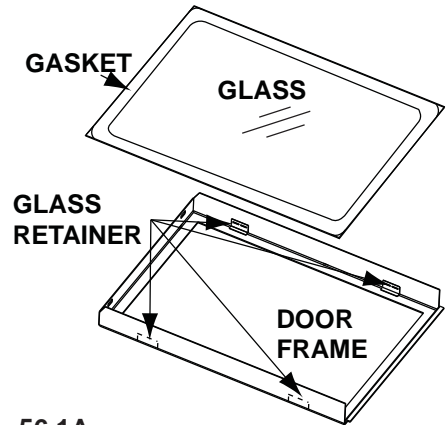

56.1A

9.4 PILOT REPLACEMENT

- A. Disconnect the 2 wires from the IPI control and the pilot connection to the valve.
- B. Remove the 3 screws that secure the pilot plate to the valve train base.
- C. Gently pull the plate away from the valve train base.
- D. Remove the 2 screws that secure the pilot to the pilot bracket.
- E. Install new pilot and reassemble.
- F. Turn on gas supply and check for gas leaks by brushing on a soap and water solution.

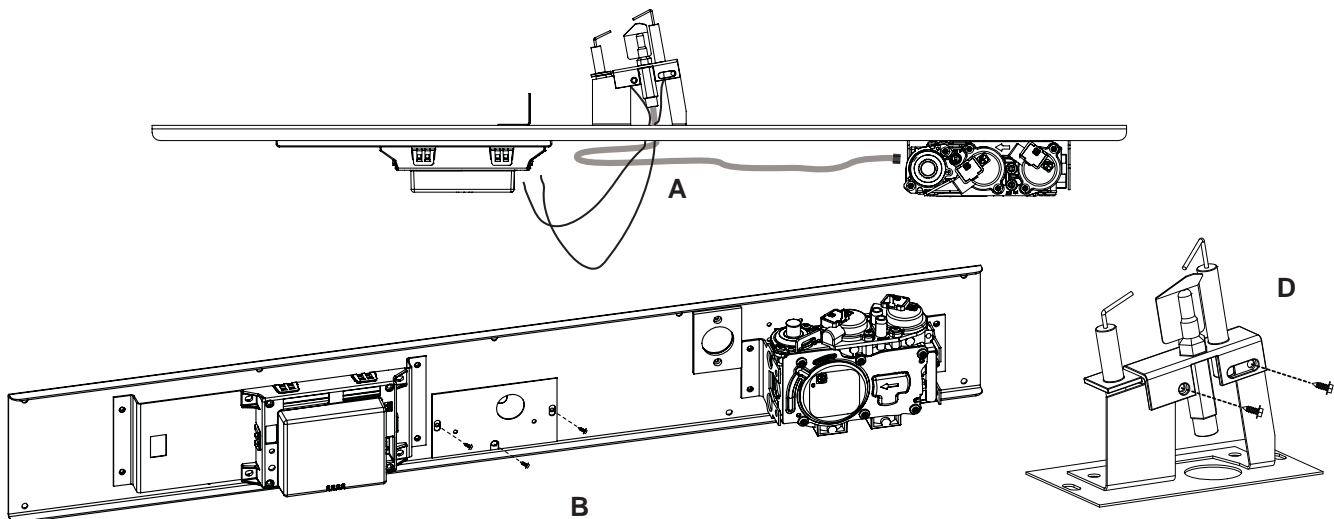

10.0 REPLACEMENTS

Contact your dealer or the factory for questions concerning prices and policies on replacement parts. Normally all parts can be ordered through your Authorized dealer / distributor.

FOR WARRANTY REPLACEMENT PARTS, A PHOTOCOPY OF THE ORIGINAL INVOICE WILL BE REQUIRED TO HONOUR THE CLAIM.

When ordering replacement parts always give the following information:

- Model & Serial Number of appliance
- Installation date of appliance
- Part number
- Description of part
- Finish

*** IDENTIFIES ITEMS WHICH ARE NOT ILLUSTRATED. FOR FURTHER INFORMATION, CONTACT YOUR AUTHORIZED DEALER.**

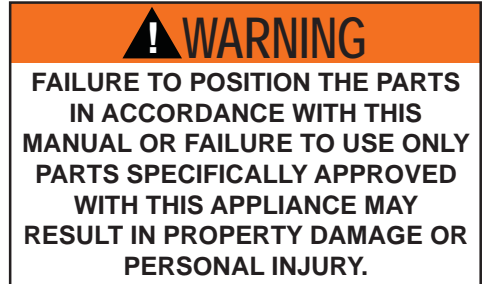

41.1

COMPONENTS		
REF NO.	PART NO.	DESCRIPTION
1	W010-2334	BLACK DOOR FRAME
2	W725-0065	NATURAL GAS VALVE
2	W725-0066	PROPANE GAS VALVE
3*	W385-0334	NAPOLEON® LOGO
4	W662-0008	NATURAL GAS PILOT
4	W662-0009	PROPANE PILOT
5	W456-0045	#45 NATURAL GAS ORIFICE
5	W456-0056	#56 PROPANE ORIFICE
6*	W300-0142	CRUSHED GLASS
7	W010-2440	REPLACEMENT GLASS C/W GASKET
8	W190-0029	CONTROL, IPI IGNITION BOARD
9	W710-0035	TRAY, MEDIA
10	W660-0009	ON/OFF SWITCH
11	W137-0001	CATALYST
12	W750-0252	WIRE, SENSOR
13	W750-0251	WIRE, IGNITOR
14	W475-0727	TOP FIBER PANEL
15	W475-0726	REAR FIBER PANEL
16*	W350-0517	BATTERY HOUSING

ACCESSORIES

REF NO.	PART NO.	DESCRIPTION
17	GD567	SAFETY SCREEN KIT
18	S31RK	RECTANGULAR SURROUND - BLACK
18	S31RN	RECTANGULAR SURROUND - BROWN
18	S31RP	RECTANGULAR SURROUND - PEWTER
19	S31CVK	CONVEX SURROUND - BLACK
19	S31CVSS	CONVEX SURROUND - STAINLESS STEEL
20*	LK31	LED LIGHT KIT
21*	W660-0081	THERMOSTAT, WALL MOUNT - DIGITAL
22*	F40	ON/OFF REMOTE
23*	F50	THERMOSTATIC REMOTE
24*	F50DR	THERMOSTATIC REMOTE - RED
24*	F50DY	THERMOSTATIC REMOTE - GREY
24*	F50DK	THERMOSTATIC REMOTE - BLACK
25*	W660-0026	PROGRAMMABLE TIMER, BATTERY OPERATED
26*	WHT31	WALL HANGING TRIM FOR S31CVSS

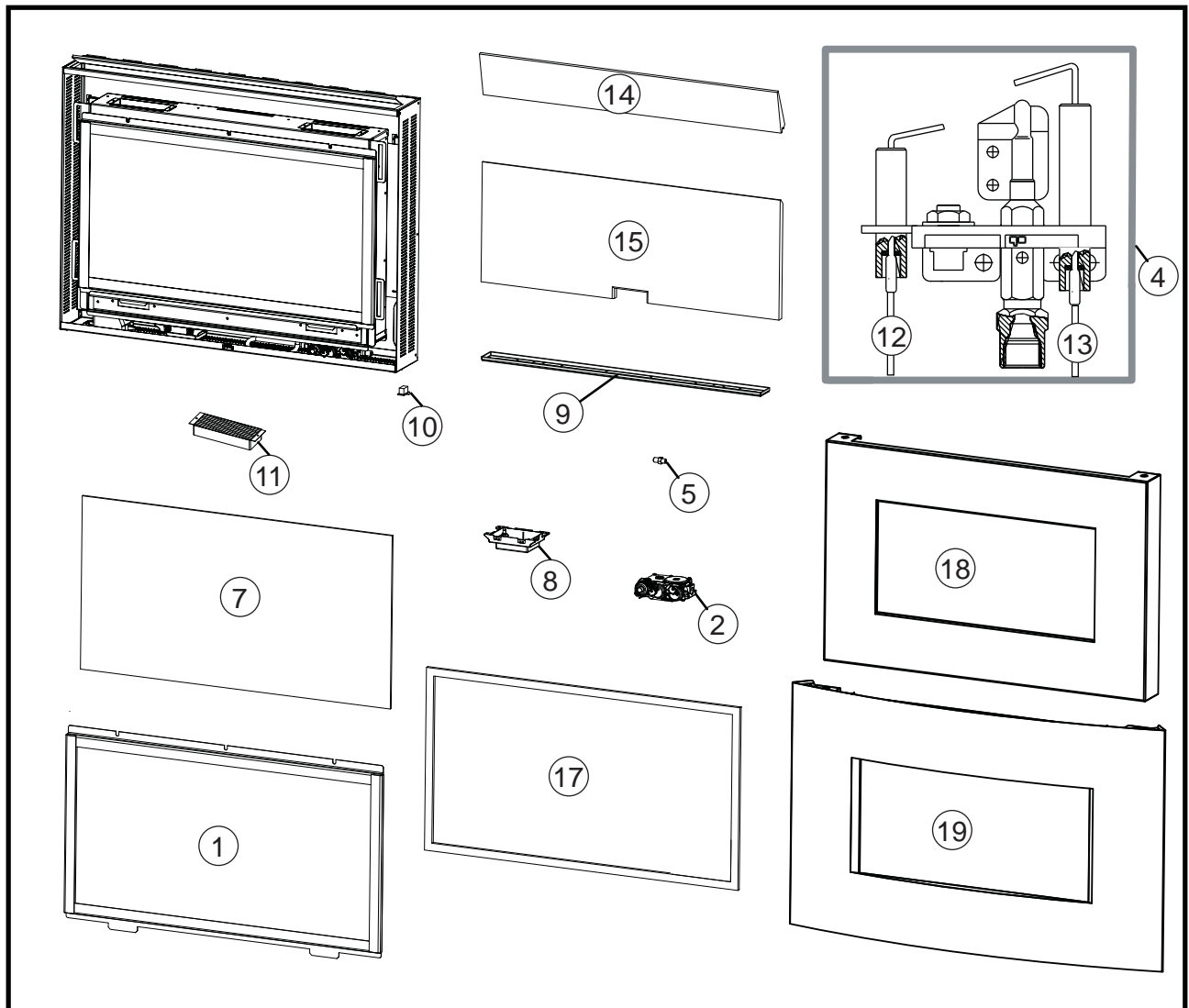

11.0 TROUBLESHOOTING

! WARNING

ALWAYS LIGHT THE PILOT WHETHER FOR THE FIRST TIME OR IF THE GAS SUPPLY HAS RAN OUT, WITH THE GLASS DOOR OPEN OR REMOVED.

TURN OFF THE GAS AND ELECTRICAL POWER BEFORE SERVICING THE APPLIANCE.

APPLIANCE MAY BE HOT, DO NOT SERVICE UNTIL APPLIANCE HAS COOLED.

DO NOT USE ABRASIVE CLEANERS.

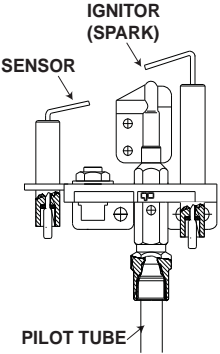
SYMPTOM	PROBLEM	TEST SOLUTION
Pilot will not light.	Wiring.	- Verify the wire for the sensor and the wire for the ignitor are connected to the correct terminals (not reversed) on the module. NOTE: Sensor has 3/16" connection and ignitor has 1/8" connection.
Makes noise with no spark at pilot burner.	Loose connection.	- Verify no loose connections, electrical shorts in the wiring or ground out to any metal object.
	Module.	- Turn the ON/OFF switch to the "OFF" position. Remove the igniter wire from the module. Place the ON/OFF switch to the "ON" position. Hold a grounded wire about 3/16" away from the ignitor (spark) terminal on the module. If no spark the ignitor terminal module must be replaced. If there is a spark the ignitor terminal is fine. Inspect pilot assembly for a shorted wire or cracked insulator around the electrode.
 <p>The diagram shows a cross-section of the pilot assembly. It includes a sensor on the left, an ignitor (spark) in the center, and a pilot tube at the bottom. Arrows point to each component with their respective labels: SENSOR, IGNITOR (SPARK), and PILOT TUBE.</p>	Igniter Spark gap is incorrect.	- Spark gap of the ignitor to the pilot should be 1/8".
	Transformer.	- Verify the transformer is installed and plugged into the module. Check voltage of the transformer under load at the spade connections on the module with the ON/OFF switch in the "ON" position. Acceptable readings of a good transformer are between 6.2 and 7.0 volts A.C.
	Battery backup (if power is off)	- Check batteries.
	A shorted or loose Connection.	- Remove and reinstall the wiring harness that plugs into the module. Remove and verify continuity of each wire in wiring harness.
	Improper switch wiring.	- Troubleshoot the system with the simplest ON/OFF switch.
	Module is not grounded.	- Verify the valve and pilot assemblies are properly grounded to the metal chassis of the appliance or log set.
	Pilot sparks but will not light.	Gas supply.
	Out of propane gas.	- Fill the tank.

42.20

SYMPTOM	PROBLEM	TEST SOLUTION
Carbon is being deposited on glass, logs, rocks, media or combustion chamber surfaces.	Air shutter has become blocked.	- Ensure air shutter opening is free of lint or other obstructions.
	Flame is impinging on the glass, logs, rocks, media or combustion chamber.	- Check that the glass, logs, rocks or media are correctly positioned. - Open air shutter to increase the primary air. - Check the input rate: check the manifold pressure and orifice size as specified in the instructions. - Check that the door gasketing is not broken or missing and that the seal is tight.
Continues to spark and pilot lights, but main burner will not light.	Short or loose connection in sensor rod.	- Verify all connections. Verify the connections from the pilot assembly are tight; also verify these connections are not grounding out to any metal.
	Poor flame rectification or contaminated sensor rod.	- Verify the flame is engulfing the sensor rod. This will increase the flame rectification. Verify correct pilot orifice is installed and inlet gas specifications to manual. (Remember, the flame carries the rectification current, not the gas. If the flame lifts from pilot hood, the circuit is broken. A wrong orifice or too high of an inlet gas pressure can cause the pilot flame to lift.) The sensor rod may need cleaning.
	Poor grounding between pilot assembly and gas valve.	- Verify that the wire harness is firmly connected to module. Verify that the ceramic insulator around the sensor rod is not cracked, damaged, or loose. Verify the connection from the sensor rod to the sensor wire.
Pilot lights Stops sparking / pilot remains lit but burner will not turn on.	Damaged pilot or dirty sensor rod.	- Clean sensor rod with an emery cloth to remove any contamination that may have accumulated on the sensor rod. Verify continuity with multimeter with ohms set at the lowest range.
	Wiring / Connection.	- Inspect all wires, ensure good tight connections. Verify that all wiring is installed exactly as specified.
White / grey film forms.	Wiring harness.	- Inspect the wiring harness, and verify the harness is tightly connected to the module. Verify that all wires are connected in the right order. See "WIRING DIAGRAM" section.
	Sulphur from fuel is being deposited on glass, logs or combustion chamber surfaces.	- Clean the glass, see "CARE OF GLASS" section DO NOT CLEAN GLASS WHEN HOT. - If deposits are not cleaned off regularly, the glass may become permanently marked.
Noisy Burner	Media Placement.	- In some installations, the glass media can lead to a "puffing" sound. Simply remove media covering burner ports.

12.0 WARRANTY

NAPOLEON® products are manufactured under the strict Standard of the world recognized ISO 9001 : 2008 Quality Assurance Certificate.

NAPOLEON® products are designed with superior components and materials assembled by trained craftsmen who take great pride in their work. The burner and valve assembly are leak and test-fired at a quality test station. The complete appliance is again thoroughly inspected by a qualified technician before packaging to ensure that you, the customer, receives the quality product that you expect from NAPOLEON®.

NAPOLEON® GAS APPLIANCE PRESIDENT'S LIFETIME LIMITED WARRANTY

The following materials and workmanship in your new NAPOLEON® gas appliance are warranted against defects for as long as you own the appliance. This covers: combustion chamber, heat exchanger, stainless steel burner, phazer™ logs and embers, rocks, ceramic glass (thermal breakage only), gold plated parts against tarnishing, porcelainized enameled components and aluminum extrusion trims.*

Electrical (110V and millivolt) components and wearable parts such as blowers, gas valves, thermal switch, switches, wiring, remote controls, ignitor, gasketing, and pilot assembly are covered and NAPOLEON® will provide replacement parts free of charge during the first year of the limited warranty.*

Labour related to warranty repair is covered free of charge during the first year. Repair work, however, requires the prior approval of an authorized company official. Labour costs to the account of NAPOLEON® are based on a predetermined rate schedule and any repair work must be done through an authorized NAPOLEON® dealer.

* Construction of models vary. Warranty applies only to components included with your specific appliance.

CONDITIONS AND LIMITATIONS

NAPOLEON® warrants its products against manufacturing defects to the original purchaser only. Registering your warranty is not necessary. Simply provide your proof of purchase along with the model and serial number to make a warranty claim. NAPOLEON® reserves the right to have its representative inspect any product or part thereof prior to honouring any warranty claim. Provided that the purchase was made through an authorized NAPOLEON® dealer your appliance is subject to the following conditions and limitations:

Warranty coverage begins on the date of original installation.

This factory warranty is non-transferable and may not be extended whatsoever by any of our representatives.

The gas appliance must be installed by a licensed, authorized service technician or contractor. Installation must be done in accordance with the installation instructions included with the product and all local and national building and fire codes.

This limited warranty does not cover damages caused by misuse, lack of maintenance, accident, alterations, abuse or neglect and parts installed from other manufacturers will nullify this warranty.

This limited warranty further does not cover any scratches, dents, corrosion or discoloring caused by excessive heat, abrasive and chemical cleaners nor chipping on porcelain enamel parts, mechanical breakage of PHAZER™ logs and embers.

This warranty extends to the repair or replacement of warranted parts which are defective in material or workmanship provided that the product has been operated in accordance with the operation instructions and under normal conditions.

After the first year, with respect to this President's Lifetime Limited Warranty, NAPOLEON® may, at its discretion, fully discharge all obligations with respect to this warranty by refunding to the original warranted purchaser the wholesale price of any warranted but defective part(s).

NAPOLEON® will not be responsible for installation, labour or any other expenses related to the reinstallation of a warranted part and such expenses are not covered by this warranty.

Notwithstanding any provisions contained in the President's Lifetime Limited Warranty, NAPOLEON'S responsibility under this warranty is defined as above and it shall not in any event extend to any incidental, consequential or indirect damages.

This warranty defines the obligations and liability of NAPOLEON® with respect to the NAPOLEON® gas appliance and any other warranties expressed or implied with respect to this product, its components or accessories are excluded.

NAPOLEON® neither assumes, nor authorizes any third party to assume, on its behalf, any other liabilities with respect to the sale of this product.

NAPOLEON® will not be responsible for: over-firing, downdrafts, spillage caused by environmental conditions such as rooftops, buildings, nearby trees, hills, mountains, inadequate vents or ventilation, excessive venting configurations, insufficient makeup air, or negative air pressures which may or may not be caused by mechanical systems such as exhaust fans, furnaces, clothes dryers, etc.

Any damages to the appliance, combustion chamber, heat exchanger, plated trim or other components due to water, weather damage, long periods of dampness, condensation, damaging chemicals or cleaners will not be the responsibility of NAPOLEON®.

All parts replaced under the President's Limited Lifetime Warranty Policy are subject to a single claim.

During the first 10 years NAPOLEON® will replace or repair the defective parts covered by the lifetime warranty at our discretion free of charge. From 10 years to life, NAPOLEON® will provide replacement parts at 50% of the current retail price.

All parts replaced under the warranty will be covered for a period of 90 days from the date of their installation.

The manufacturer may require that defective parts or products be returned or that digital pictures be provided to support the claim. Returned products are to be shipped prepaid to the manufacturer for investigation. If a product is found to be defective, the manufacturer will repair or replace such defect.

Before shipping your appliance or defective components, your dealer must obtain an authorization number. Any merchandise shipped without authorization will be refused and returned to sender.

Shipping costs are not covered under this warranty.

Additional service fees may apply if you are seeking warranty service from a dealer.

Warranty labour allowance is only for the replacement of the warranted part. Travel, diagnostic tests, shipping and other related charges are not covered by this warranty.

ALL SPECIFICATIONS AND DESIGNS ARE SUBJECT TO CHANGE WITHOUT PRIOR NOTICE DUE TO ON-GOING PRODUCT IMPROVEMENTS. NAPOLEON® IS A REGISTERED TRADEMARK OF WOLF STEEL LTD.

