

*Owner's Manual*

# WOODMASTER®



[www.woodmaster.com](http://www.woodmaster.com)

## *Models:*

**3300**

**4400** *Heavy Duty*

**5500** *Super Duty*

**6500** *Super Duty*

**Installation, Operation  
& Maintenance Manual**

*Northwest Manufacturing, Inc.*

*600 Polk Ave SW*

*Red Lake Falls, MN 56750*

*Retain this manual/Conserver ce manuel*

7994-500



Natural Energy Furnaces  
■ Northwest Manufacturing, Inc.  
600 Polk Ave. SW  
Red Lake Falls, MN 56750

Dear Customer,

We at Northwest Mfg., Inc. would like to thank you for purchasing the WoodMaster heating system.

It is our goal to build the highest quality product at a competitive price, and maintain total customer satisfaction.

This manual is a guide for installing, operating, and maintaining your new WoodMaster.

Follow and observe all safety and warning instructions.

The Staff,

A handwritten signature in black ink that reads "Chuck Conroy".

WoodMaster Furnaces

Web: [www.woodmaster.com](http://www.woodmaster.com)

# Table of Contents



Woody  
Woodmaster

|  |       |
|--|-------|
| Table of Contents .....                          | 3     |
| Best Burn Practices .....                        | 4     |
| Safety .....                                     | 5     |
| Features .....                                   | 6     |
| Installation.....                                | 7     |
| The Furnace.....                                 | 7     |
| Choosing Location.....                           | 7     |
| Chimney Specifications .....                     | 7     |
| Block or Pad Supports .....                      | 7     |
| Trench .....                                     | 7     |
| Mounting the Pump .....                          | 8     |
| Hooking Up Water Lines .....                     | 8     |
| Wiring the Pump.....                             | 8     |
| The Home .....                                   | 9     |
| Domestic Hot Water.....                          | 9     |
| Existing Forced Air.....                         | 9     |
| Existing Hot Water Heat .....                    | 10    |
| Inline Filter and Fill Valve.....                | 10    |
| Auger Assembly.....                              | 10    |
| Operation.....                                   | 11    |
| Filling with Water.....                          | 11    |
| Bleeding the System.....                         | 11    |
| Firing the Furnace .....                         | 12    |
| Loading the Furnace.....                         | 12    |
| Boiler Treatment.....                            | 13    |
| Ash Rotation.....                                | 13    |
| Ash Removal and Disposal .....                   | 13    |
| Maintenance.....                                 | 14    |
| Baffle Bypass Chamber Ash Removal .....          | 14    |
| Creosote -- Formation and Removal .....          | 14    |
| Annual WoodMaster Maintenance .....              | 14    |
| Boiler Treatment.....                            | 14    |
| Troubleshooting .....                            | 15    |
| E.T.C. Guide .....                               | 16    |
| E.T.C. Reference.....                            | 17-22 |
| Wiring Diagrams.....                             | 23    |
| Technical Specifications & Slab Dimensions ..... | 24    |
| Warranty.....                                    | 25    |



Woody  
Woodmaster

# Best Burn Practices

1. Read and follow all operating instructions supplied by the manufacturer.
2. **FUEL USED:** Burn only split and seasoned wood with 25% moisture content or less. **DO NOT** burn green wood. Never use the following: trash, plastics, gasoline, rubber, naphtha, household garbage, material treated with petroleum products (particle board, railroad ties and pressure treated wood), leaves and cardboard. Paper products should only be used when firing your furnace.
3. **LOADING FUEL:** For a more efficient burn, pay careful attention to loading times and amounts. Follow the manufacturer's written instructions for recommended loading times and amounts.
4. **STARTERS:** Do not use lighter fluids, gasoline, or chemicals. Use paper products and kindling only.
5. **LOCATION:** It is recommended that the unit be located with due consideration to the prevailing wind direction.
  - When using more than 4 feet of chimney extension external support is needed.
  - Must be located at least 25 feet from the property line
  - Should be located greater than 100 feet from any residence not served.
  - If located between 100 and 300 feet to any residence not served, it is recommended that the stack be at least 100% of the height of the peak of the residence, plus an additional 2 feet.

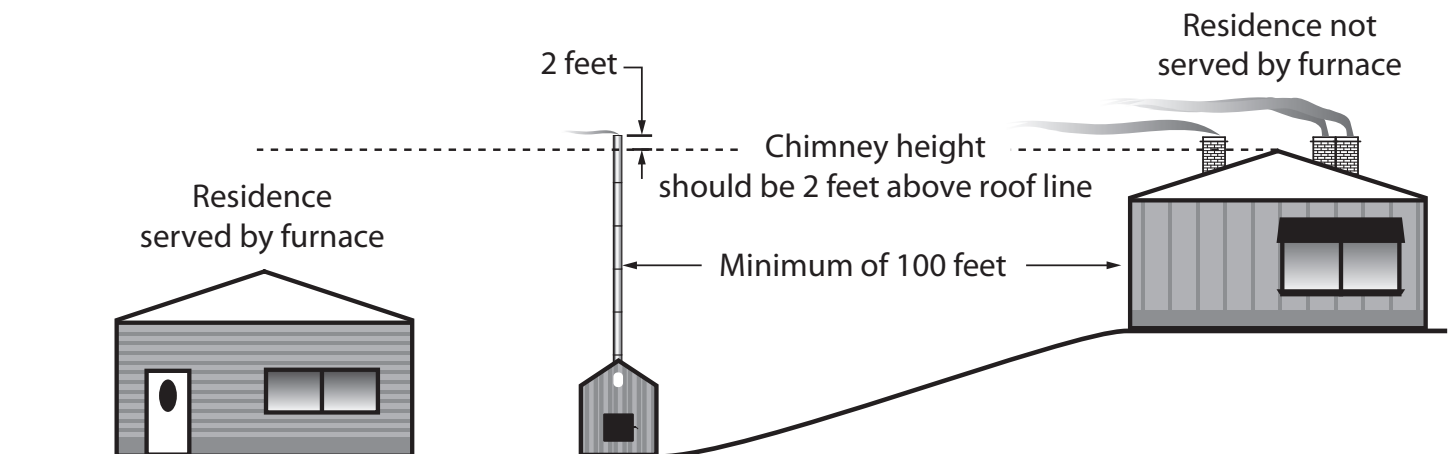

6. Always remember to comply with all applicable state and local codes.

# Safety

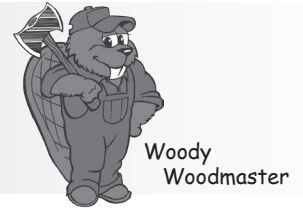

## IMPORTANT SAFETY INSTRUCTIONS READ ALL INSTRUCTIONS BEFORE INSTALLATION

### Pre-Installation Precautions

#### CAUTION!!

All installation and operations must follow STATE and LOCAL CODES for wiring, plumbing, and firing of this unit. These CODES may differ from this manual. Installation must be performed by a Qualified Installer.

#### CAUTION!!

Read and follow these directions carefully. Retain this manual for as long as you own your WoodMaster.

#### CAUTION!!

All WoodMaster models operate at atmospheric pressure. DO NOT obstruct, block, or plug in any way the overflow vent pipe which is located directly behind the chimney on top of the furnace.

#### CAUTION!!

The WoodMaster is designed for outdoor use. We do not recommend installing in a building.

#### CAUTION!!

Manufacturer recommends a minimum 25 foot clearance from buildings or fire hazards. If placed near a fire hazard area an approved spark arrester should be used.

#### CAUTION!!

Only responsible adults should operate your furnace. If furnace is not fired properly damage could result and the warranty be voided.

#### CAUTION!!

Never allow small children to play near or tamper with furnace. Always keep the area around, and in front of fuel door clean and free from combustible materials.

#### CAUTION!!

Do not connect this unit to a chimney flue serving another appliance.

#### CAUTION!!

Load Wood Carefully to avoid injury to hands and fingers that may come into contact with furnace opening.

#### CAUTION!!

Pump must run continuously whenever the WoodMaster is being used.

#### CAUTION!!

Cut split seasoned wood is the recommended fuel. (approximately 25% moisture or less)

## IMPORTANTS INSTRUCTIONS DE SECURITÉ LISEZ TOUT CES INSTRUCTIONS AVANT L'INSTALLATION

### Precautions a prendre avant l'installation

#### ATTENTION!!

Tout installations et opérations doivent être faites en accord aux régulations en force dans votre localité, province ou état pour le cablage électrique, la plomberie et l'opération de cette unité. Ces régulations peuvent différer de celle de ce manuel. L'installation doit être entrepris par un Technicien Qualifié.

#### ATTENTION!!

Lisez et suivez attentivement ces directions. Conservez ce manuel aussi longtemps que vous possederez votre WoodMaster.

#### ATTENTION!!

Tous les models WoodMaster s'opèrent à la pression atmosphérique. NE PAS boucher ou crée d'obstructions qui pourrai restreindre de débit du tuyau de surcharge situé directement a l'arrière de la cheminée en haut de foyer.

#### ATTENTION!!

Le WoodMaster a été conçue pour être utilisé a l'extérieure. Nous ne recommandons pas qu'il soit installé a l'intérieure d'un bâtiment.

#### ATTENTION!!

Il est recommandé par le fabricant qu'une distance minimal de 25 pieds entre le foyer et tout batiments ou zone inflammable. Si placé à proximité d'une zone inflammable, une barrière anti-étincelles doit être utilisé.

#### ATTENTION!!

L'opération de la chaudière doit être restreinte aux adultes responsable. Si la chaudière n'est pas operé proprement, elle risque d'être endommagé et la garantie serait annulé.

#### ATTENTION!!

Ne jamais permettre aux enfants de jouer a proximité ou de toucher la chaudière. Gardez toujours les alentours et l'avant de la porte propre et sans matériaux combustibles.

#### ATTENTION!!

Ne pas connecter cette unité à une chemine utilisé par un autre équipement.

#### ATTENTION!!

Faites attention à vos mains et doigts en mettant le bois au four afin d'éviter de les coincer entre le bois et les bords de la porte.





Woody  
Woodmaster

# Features

## Front View

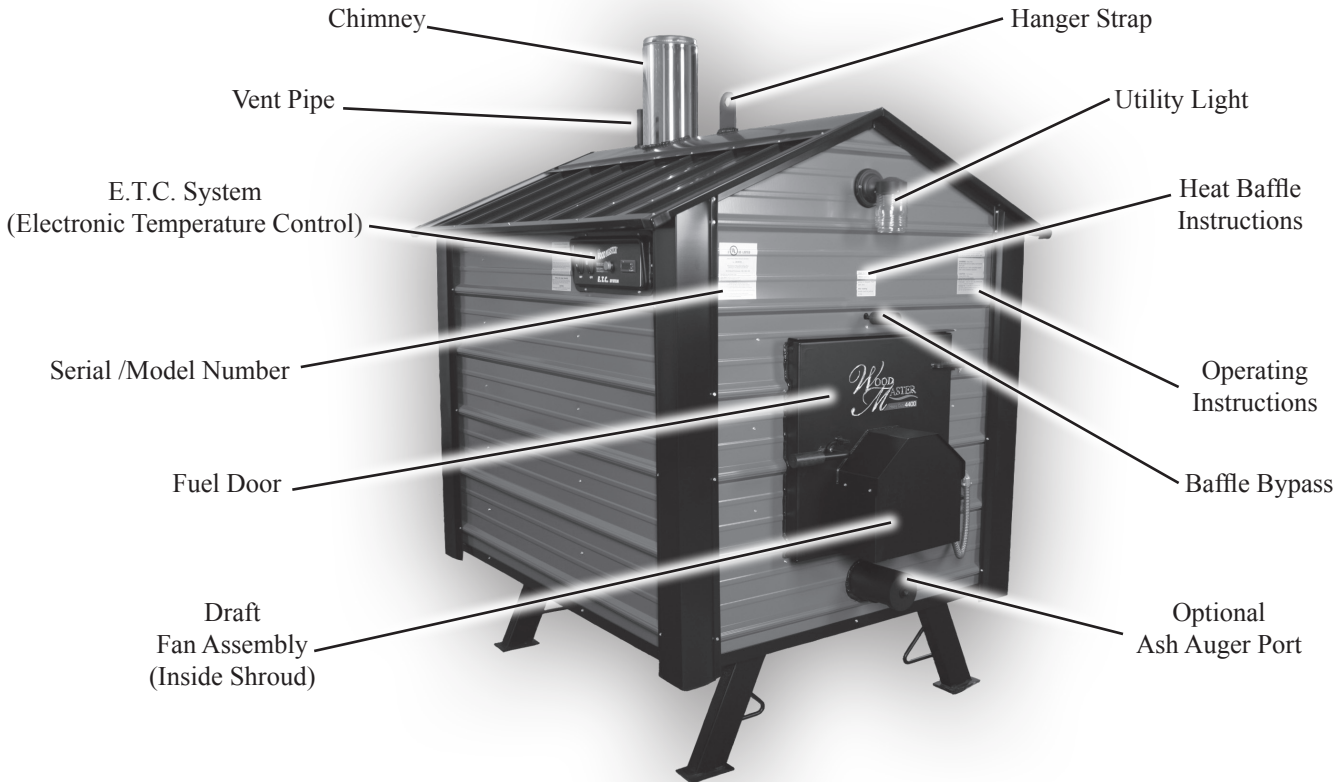

## Rear Panel

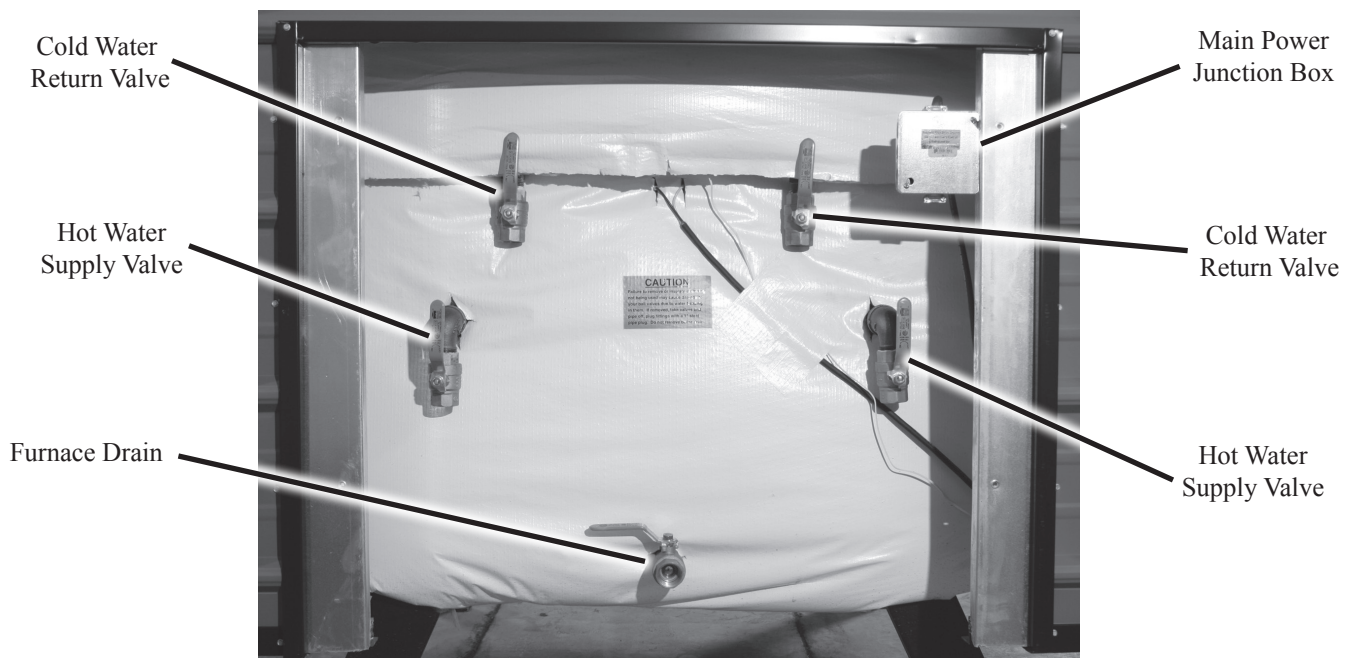

(4400 shown)

# Installation

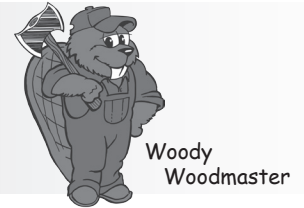

## THE FURNACE

### Choosing Location

The WoodMaster is designed for outdoor use. We do not recommend installing in a building. When installing your WoodMaster, keep in mind the direction of the winds during heating months. Try to place the furnace in an area where exhaust will not be a problem for yourself or any surrounding neighbors.

### Chimney Specifications

To insure proper insulation, use only a Class A Insulated Chimney and Chimney Adapter from your local WoodMaster Dealer or Northwest Mfg., Inc.

**CAUTION!!!**  
Using a non-insulated chimney or failure to use a Class A Insulated Chimney **WILL** result in a voided warranty

### Block or Pad Supports

Under normal conditions four cement blocks are all that is required to support the furnace. Blocks should be at least 6 inches wide, 10 inches long, and 3 inches thick. Under very soft conditions a concrete pad may be needed. For Model 4400 the pad should be no less than 5 feet wide, 6 feet long, and 4 to 6 inches thick. For Model 5500 no less than 6 feet wide, 7 feet long, and 4 to 6 inches thick. Always use a non-combustible base. **For model specific Slab Dimensions, see page 21 in this manual.**

**CAUTION!!!**  
Call Before you dig.

### Trench

The trench must be 24 inches deep and 6 to 12 inches wide. It can be dug with a shovel or a backhoe. Place all the dirt to one side of the trench to allow room for working on the other side.

#### **Wiring**

Place electrical supply in bottom of trench and cover with 6 inches of dirt. Electrical wire rated for underground use (14-2 +ground or 12-2 + ground for the 6500) can be buried in the same trench as the water lines but must maintain a minimum 24 inch depth. Always follow state and local codes.

#### **Water Lines**

The remaining 18 inches of open trench is where the water lines are placed. Use a one inch water line with a minimum rating of 100 PSI at 180 degrees and insure that your water line insulation has a minimum R-value of eight in order to maintain adequate heating efficiency.

**NOTE:** If lines travel under a driveway or where heavy equipment travels, the line should be buried two to three feet deep. If lines travel through a low or wet area, they should be insulated and installed in a water tight piping, (PVC).

**NOTE:** Leave a minimum of three feet of water line exposed above ground at the furnace to insure adequate length for connection.

**NOTE:** Before insulating and burying the water lines, label the hot water supply line at both ends. Once the lines are covered you will be able to easily determine which line is connected to the pump.

**NOTE:** Use only approved water line insulation sold through your WoodMaster Dealer. Poor insulation will cause your WoodMaster furnace to burn large amounts of wood.



Woody  
Woodmaster

# Installation

## THE FURNACE

### Mounting the Pump

Attach the 1" x 2" Black Nipple (0020-250) and one half of the Flanges from the 1" Cast Iron Pump Flange Kit (0020-368) to one of the Hot Water Supply Valves on back of furnace.

Locate one of the Black Rubber Gaskets, and place it between the Pump and the Mounted Flange, bolt the Pump to the Flange. Make sure the arrow on the pump indicating direction of water flow points down.

Bolt the remaining Flange and Gasket to the bottom of the Pump.

**NOTE:** Make sure that the pump is attached to the supply line, not the return.

Cold Water  
Return Valves

Hot Water  
Supply Valves



4400 (pictured)

### Hooking Up Water Lines

#### Hot Water Supply

Attach the 1" Pex x 1" MIP fitting (0020-140) to Flange on bottom of the Pump. Then attach the hot water supply 1" Pex Water Line (0020-130) to the fitting using 1" Pex Crimp Ring (0020-145).

#### Cold Water Return

Attach the 1" Pex x 1" MIP (0020-140) fitting to the Cold Water Return Valve on the same side of the furnace on which the Pump was attached. Then attach the cold water return 1" Pex Water Line (0020-130) to the fitting using 1" Pex Crimp Ring (0020-145).

**Note:** A 1" male Sharkbite Adapter (0020-510) may be substituted for the 0020-140 & 0020-145.

### Wiring The Pump

Remove the cover on the Pump. Then using an approved wire, connect the Ground Wire to the Green Ground Screw on the Pump. Connect the Black Wire to the Yellow Wire on the Pump. Finally, connect the remaining two White Wires together and replace the Pump Cover.

Locate Junction Box on back of furnace and remove the cover. Connect the running end of the approved wire coming from the Pump to the Junction.

**NOTE:** The Wires from the Pump will have to connect with the Main Power Wires in the Junction Box along with the Power Wires from the ETC System.

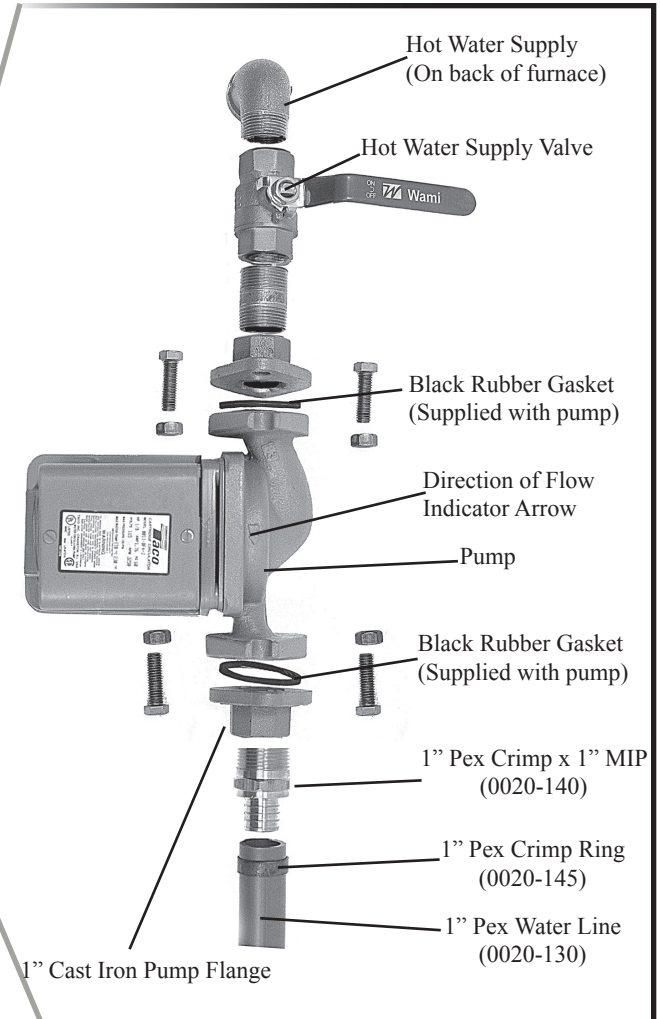

**Caution!!**  
Never run the pumps dry!! The furnace must be full of water and the valves must be open.

**Caution!!**  
The pump must run continuously whenever the Woodmaster Furnace is in use. It cannot be wired to thermostats that only run the pump when the building calls for it.

**Caution!!**  
Disconnect power before servicing any electrical components.



# Installation



Woody  
Woodmaster

## THE HOME

Entering the building with water lines can be done underground or over the sill plate. Once inside the building the typical hookup would run first to the Domestic Hot Water Supply and next to an existing heating system such as a forced air furnace or a hot water heating system. Finally, before leaving the building, a fill valve must be installed near enough to a water supply for filling and flushing the boiler in the WoodMaster furnace.

### Domestic Hot Water

The Domestic Hot Water/Flatplate Kit consists of a Water to Water Heat Transfer unit and the fittings needed to hook it up. The unit mounts on the wall **VERTICALLY** in your utility room and is connected as shown below.

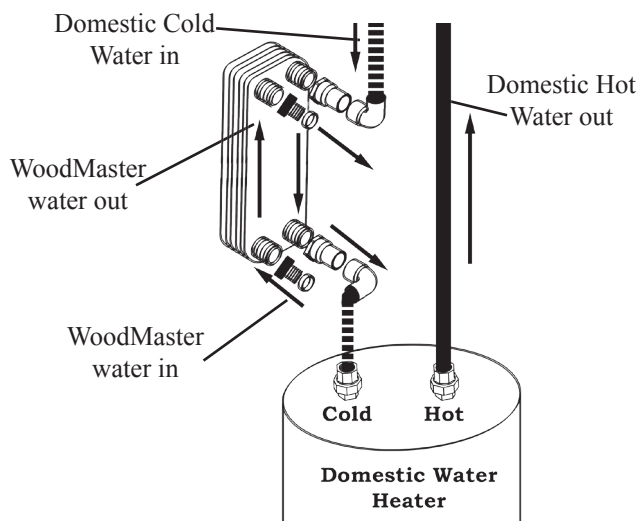

### Existing Forced Air

A water to air heat exchanger is inserted in the existing plenum. In most cases the heat exchanger is placed in a horizontal position, keeping all four sides level. The air must be forced through the finned area of the heat exchanger evenly. The hot water line coming from the hot-water tube enters the bottom fitting of the heat exchanger and exits the top fitting, which returns to the furnace. If the plenum is too large or too small, it must be altered to fit the heat exchanger properly.

NOTE: The WoodMaster Plus Water to Air Heat Exchanger must be installed below any existing Off-Peak electric coils already in the plenum.

After the installation of the WoodMaster add-on water to air exchanger, the air flow may need to be increased to fuel furnaces, electric furnaces, and electric/gas furnaces. Methods of doing this are:

#### Belt Drive System

Blower pulleys and motor pulleys may be changed but the electric current flowing through the motor shall not exceed the nameplate rating. (A blower motor or larger power may be used.)

#### Direct Drive System

The motor shall not be changed, however the speed of the motor may be increased.

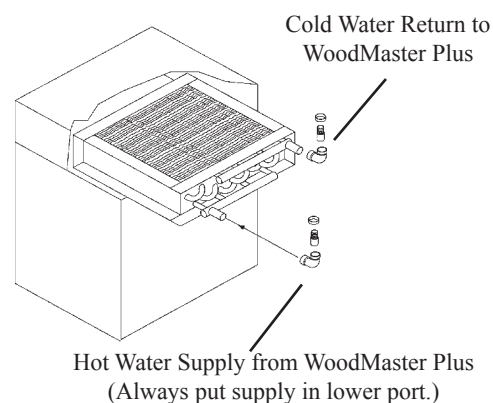
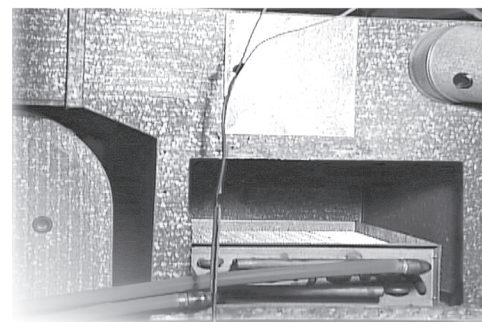

The heat exchanger works on the same principle as your car heater. Air blows through the heat exchanger, taking the heat from the water and blowing it into your existing duct work.

### **Caution!!**

**All wiring must follow state and local codes and should be done by a qualified electrician. Wire thermostats according to directions provided by the manufacturer.**



Woody  
Woodmaster

# Installation

## Existing Hot Water Heat

A Water to Water Heat Transfer Unit (0020-052) is used to connect to an existing hot water boiler system.

**NOTE:** Any changes that are made to an existing boiler should be done by a qualified plumber and follow all state and local codes.

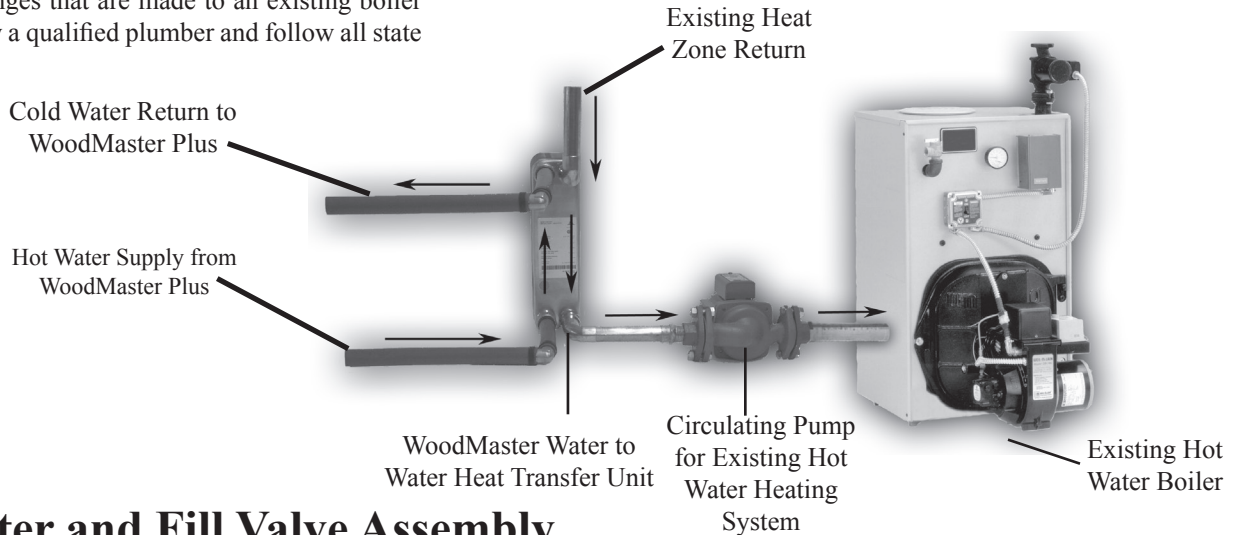

## Inline Filter and Fill Valve Assembly

The Inline Filter and Fill Valve Assembly (0020-275) must be installed in the Cold Water Return Line before the line exits the building. It should be placed so that a garden hose can be connected between a domestic water supply and the Fill Valve.

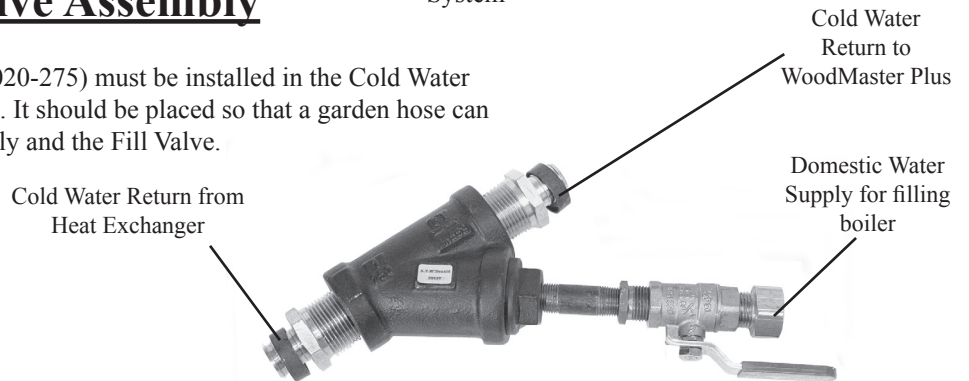

## Auger Assembly

Place the auger carriage in the furnace, insert the center auger through the auger tube and align with the stub shaft on the back of the carriage.

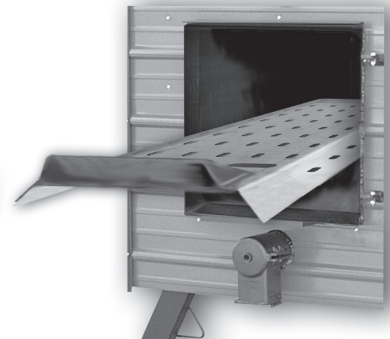
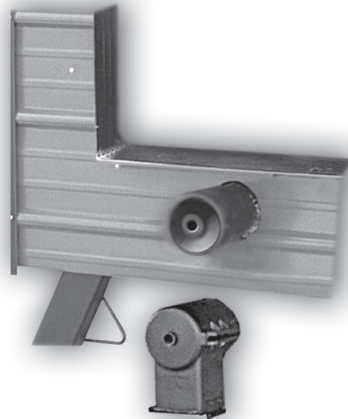
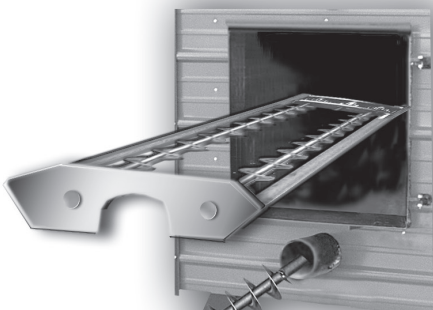

Insert the grate and place over the top of auger carriage.

Place the auger cap over the auger tube and align the center auger shaft with the hole in the auger cap. The Auger cap should completely slide on tube. If this does not happen, the center auger is not all the way on stub shaft. Rotate auger, while pushing in, to insure the cap and auger are installed properly. Tighten the auger cap.

**NOTE:** The Ash Auger and grate must be removed after each heating season for cleaning and maintenance .

# Operation

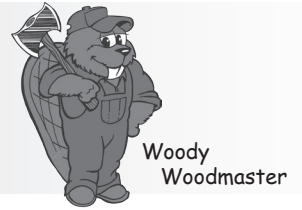

## Filling With Water

Connect a garden hose between a domestic water supply and the furnace fill valve (0020-275), which was installed in the cold water return line at a point just prior to its exiting the building. Make sure that valves not being used on the furnace are closed and the valves that are being used are open. Begin filling and inspect for leaks on all fittings. Repair any leaks that are found.

**CAUTION!!!**  
Feed and return valves that are not being used must be insulated or removed to prevent freezing and breaking.

Routinely pay attention to the water level light. If the light is not lit, this indicates that the water level is low and the furnace may need to have water added. Add water until it flows out of the vent pipe.

**CAUTION!!!**  
Air in the water lines can cause damage to the pump.

## Bleeding The System

While filling the boiler, close the cold water return valve on the furnace for two or three minutes, and then open the valve. This will force trapped air out of the hot water supply line. Repeat this process with the hot water supply valve on the furnace to force air out of the cold water return line. Once both lines have been “bled” continue filling the furnace until the system is full and water comes out of the vent pipe.

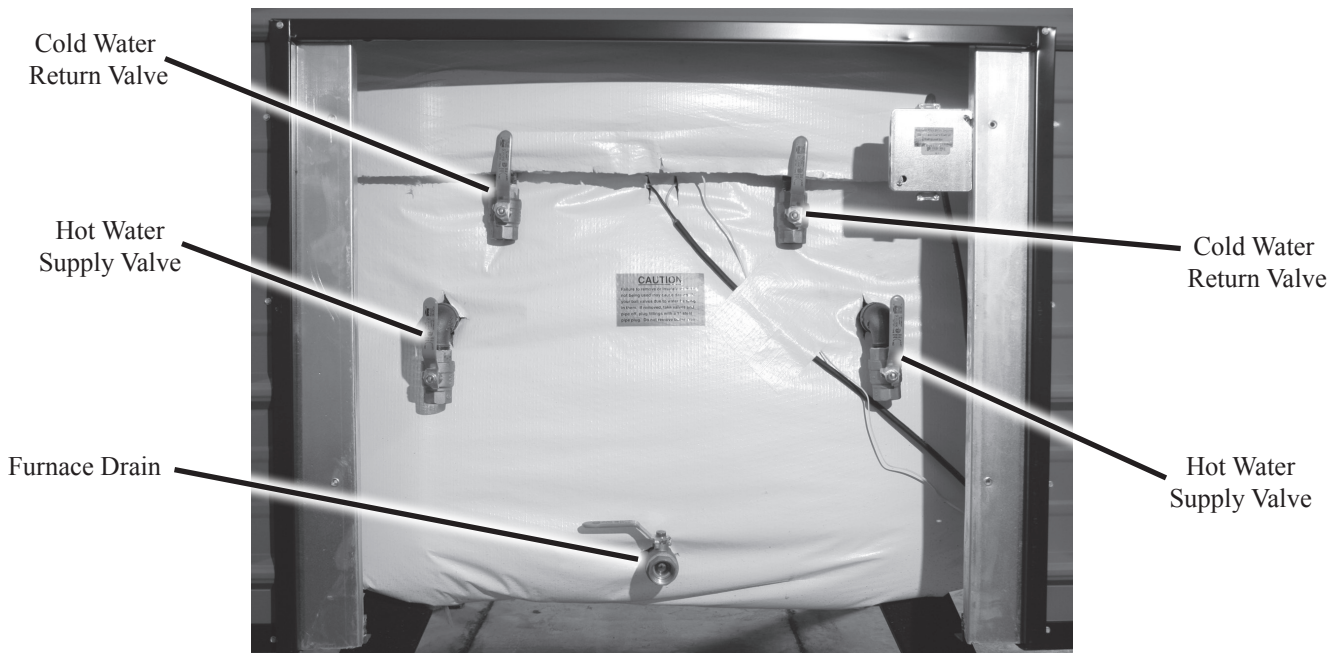

4400 (pictured)



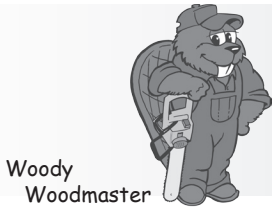

# Operation

## Firing The Furnace

Paper and kindling should be used for starting the fire. Build a small fire, then add wood as needed. Be sure that the pumps are circulating when firing the furnace. Once the furnace has reached 170 degrees, the furnace is ready to be filled to capacity to operate for a 12 hour period. Load wood towards the back of the furnace for improved efficiency. WoodMaster recommends burning cut, split and seasoned wood. Do not overfill so that hot coals fall out of the furnace when opening the fuel door. During periods of warmer weather, you may find it to have creosote inside the firebox. It is important to fill the furnace only with enough wood to last a 12 to 24 hour period. After burning your furnace for a period of time, you will discover how much wood is needed per day and what types of wood burn the best.

### CAUTION!!!

Do not fire with garbage, rubber, gasoline or any oil products. Do not use chemicals or any oil products that were listed above to start fires.

## Loading the Furnace

Before opening the fuel door pull the Bypass Baffle rod out to the first stop point to vent the furnace. Use caution when opening the fuel door since fire and high temperatures may be present. When loading your furnace the manufacturer recommends that you stack your wood lengthwise in two rows as shown below. This will allow air from the draft fan to circulate properly creating the optimum burn environment.

### SIDE VIEW



### FRONT VIEW



Load the back of the furnace first, stacking the wood lengthwise in the fire box. After the rear is loaded, fill the front of the furnace in the same fashion. Be mindful of the latch on the door when you are stacking the wood in the front.

**Note:** The amount of wood needed to heat your system will vary depending on many different factors. System design, insulation values and type of wood are a few of the contributing factors that will determine how much wood is needed.



# Operation

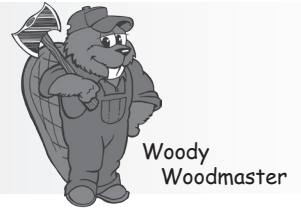

## Boiler Treatment

Allow the system to burn for 2 hours and then add the boiler treatment as follows: Make sure that the water temperature is at least 100 degrees or higher. Add the boiler treatment that came with your furnace to the vent pipe located directly behind the chimney. Treatment must be added on an annual basis. If you are interested in testing the water in your furnace, contact your local dealer for details. For details on how to add your treatment while performing your annual maintenance, refer to page 14.

## Ash Rotation

Maintaining proper ash rotation is crucial to the performance of your WoodMaster furnace. Keeping a fresh bed of coals on the top of your ashes will ensure that you get the most out of whatever kind of wood that you burn by burning and breaking down the wood to its smallest usable form. To make sure that you are rotating your ashes properly, follow the instructions below.

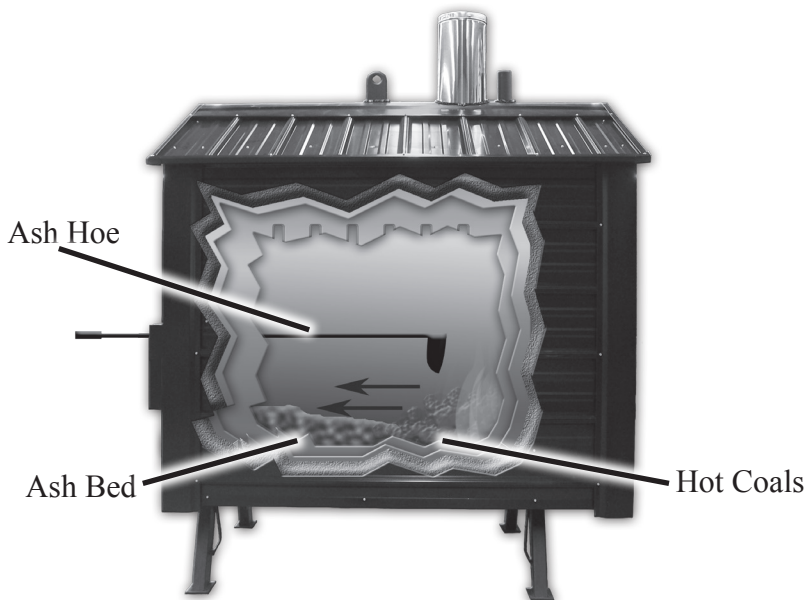

1. With your Ash Hoe, pull the hot coals from the back of the furnace to the front.
2. Load the back of the furnace first, stacking the wood as shown in the previous section. Then fill the front of the furnace.

By loading the furnace as explained, the flame will be towards the front of the furnace and work its way back. This will cause your wood to burn more thoroughly.

## Ash Removal and Disposal (Weekly or as needed)

Remove the ashes when the furnace is very low on wood. If your WoodMaster furnace is not equipped with an Ash Auger System use a shovel to take the ashes from the front of the firebox and use a rake to pull the ashes from the rear of the furnace to create a level bed of hot coals. The ashes should be placed in a metal container with a tight fitting lid. The closed container of ashes should be placed on a noncombustible floor or on the ground and well away from all combustible materials, pending final disposal. Ashes should be retained in the closed container until all of the cinders have thoroughly cooled.

### **CAUTION!!!**

Hot coals can last for days, disposing of them improperly or too soon can cause a fire.



Woody  
Woodmaster

# Maintenance

## **Baffle Bypass Ash Removal (Weekly or as needed)**

To ensure that your Baffle Bypass remains clear of any excessive build-up, you will need to clean it out. To effectively clean out the Baffle Bypass you must:

1. Pull the rod back until it hits the stop.
2. Twist the rod clockwise and pull back in order to pass over the stop.
3. Slide rod in and out several to clean the Baffle Bypass.
4. Slide the rod all the way in.

## **Creosote -- Formation and need for removal**

When wood is burned slowly, it produces tar and other organic vapors, which combine with expelled moisture to form creosote. The creosote vapors condense in the relatively cool chimney flue of a slow-burning fire. As a result, creosote residue accumulates on the flue lining. When ignited this creosote makes an extremely hot fire. The chimney connector and chimney should be inspected at least twice monthly during the heating season to determine if a creosote buildup has occurred. If creosote has accumulated it should be removed to reduce the risk of a chimney fire.

## **Annual WoodMaster Maintenance**

PROTECT your fire chamber by placing the chimney cap over the chimney during the off-season, inspect all silicone caulking and make sure it has a good seal so moisture can't enter furnace. If you have an ash auger, remove it, clean out all ashes and scrape excess creosote from the fire chamber surface. Reinstall the ash auger. Moisture combined with ashes will eat through metal in a very short time.

### **CAUTION!!!**

Warranty does not cover ash corrosion! Neglecting to clean your furnace or cover the chimney, when not in use, will void your warranty. When the furnace is in use, be sure that you maintain a good ash rotation. This should be done weekly.

If you are using a spark arrester or a chimney cap, you will need to provide your furnace with a little more maintenance. It is very important that you keep these areas free of any creosote build up at all times. Failure to do this will cause harm to the roof of your furnace.

### **Caution!!**

Use of a Spark Arrester or chimney cap will require extra care and maintenance. If you don't maintain it properly, it may cause damage to your roof.

## **BOILER TREATMENT:**

It is very important to drain and flush your furnace each spring. To drain furnace -- open drain valve and let furnace empty completely. To flush -- leave drain valve open and close pump valve. Add water to furnace through the return lines. Let flush for several minutes. Close drain valve and open pump valve. Refill furnace and treat water **right away**.

Leaving your furnace empty exposes the water jacket to oxygen which will shorten the life of your furnace. If your system has anti-freeze, you do not need to drain it. However you should then test your water annually. For water sampling contact your dealer.

### **Caution!!**

You must fill with boiler treatment annually.

# Troubleshooting

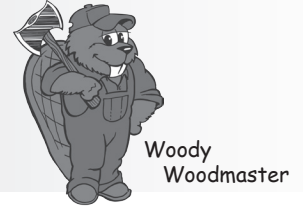

## If furnace is not heating:

1. Check fire.
2. Check pump. If pump is not running, shut off power supply to pump and inspect.
3. Check water level. If water is low, inspect for leaks in the system.
4. Check chimney for creosote build-up. If opening is reduced fire cannot burn properly.
5. Check Fan Draft and Draft Flapper. Make sure they are operating properly.
6. Check Fan Switch on ETC to be sure it is ON. Fan Switch should only be off while filling or cleaning.
7. If water temperature is reading 120° or lower, push Set Button on ETC System to restart Heating Mode.

## Furnace boils:

1. Check fire door. Be sure door was not left open.
2. Check fire door rope. This is the fire resistant gasket around the Fuel Door. Make sure the door has a tight seal.
3. Check air intake on fire door. Make sure cover closes tight.
4. In extremely warm weather, a smaller amount of wood should be used.
5. Check Auger Head for air leaks and that Ash Auger Head Discharge Door is closed.

NOTE: If furnace boiled water out and air entered lines this could damage pump. Be sure to remove air from system. (See Filling With Water on page 11.) A hissing sound coming from the pump, in most cases, means there is air in the system. Check water level to insure that your furnace is full.

If none of these suggestions appear to solve your problem, contact your dealer.



Woody  
Woodmaster

# E.T.C. Guide

## ELECTRONIC TEMPERATURE CONTROL (ETC):

### **Function:** (Factory Settings below)

- The ETC monitors and controls the WoodMaster water temperature by controlling the draft and draft fan.
- During normal operation (adequate wood supply) the controller will turn off the draft and draft fan when the water reaches 170° F (Set) and will turn on the draft and draft fan when the water falls 10° F (Hy).
- During shut down (low wood supply) or when the water falls to 120° F (ALL) the controller will shut off the draft and draft fan. At this time, the WoodMaster will need to be filled with wood and the ETC will need to be reset (see Startup)

### **Energy Start Shut-Down:**

- This function shuts down the WoodMaster draft and draft fan when not in use and back-up system is operating (example: if gone for the weekend, wood firing furnace runs out of wood and back-up system takes over). To restart the WoodMaster, simply push the Set Button.

### **Start Up / Reset**

- The first time the WoodMaster is powered up or when it has shutdown, the controller display will flash “LA” (Low Alarm) two times and then display the water temperature for two seconds and then start over. This is normal and indicates the system has shut down because the water is at or below 120° F.
- To start up (or reset) your WoodMaster, press the set button one time. The display will indicate “rSt” (reset) and after 1 to 2 seconds, the draft will open and the draft fan will turn on. The display will continue to flash “LA” and the water temperature will be displayed until the water temperature reaches 140° (ALL + 20). After water temperature reaches 140° F, only the water temperature will be displayed until the water temperature falls to 120° F.
- **Note:** The fan switch must be in the on position.
- **Note:** Fan switch can be shut off when loading or for servicing.

### **Parameter Description and Factory Settings:**

- Set (set point) - 170° F
- Hy (Differential) - 10° F
- ALL (Low Alarm) - 120° F

### **How To:**

- **View Set Point** — Push and immediately release the set key, display will indicate set point and will return to water temperature after 5 seconds.
- **Change the Set Point** — Push and hold the set key until the set point is displayed, change the value using the up and down arrows, and press the set key. The set point will flash a few times and then the display will return to water temperature.
- **Change Hy or ALL** — Push and hold the set and down arrow keys at the same time until HY is displayed. Using the up and down arrows, select the parameter to be changed (Hy or ALL), push the set key once (value of parameter should be displayed), use arrows to change value, and push the set key (value should flash a few times). After 10-15 seconds the display will change back to water temperature.

### **Green Float Light:**

- Green light on: Water level O.K.
- Green light off: Water level low, add water through vent pipe.

**Light Switch:** Operates light.

**Fan Switch:** The fan switch must be on during normal operation, but may be turned off to fill furnace or for maintenance.





# E.T.C. Reference



Woody  
Woodmaster

## Digital custom controller XR30C FOR WOODMASTER

### CONTENTS

|                                       |   |
|---------------------------------------|---|
| 1. GENERAL WARNING                    | 1 |
| 2. GENERAL DESCRIPTION                | 1 |
| 3. CONTROLLING LOADS                  | 1 |
| 4. FRONT PANEL COMMANDS               | 1 |
| 5. TEMPERATURE ALARM AND ITS DURATION | 1 |
| RECORDING (HACCP)                     | 1 |
| 6. MAIN FUNCTIONS                     | 2 |
| 7. PARAMETERS                         | 2 |
| 8. ALARM SIGNALS                      | 2 |
| 9. DEFAULT SETTING VALUES             | 2 |

### 1. GENERAL WARNING

#### 1.1 PLEASE READ BEFORE USING THIS MANUAL

- This manual is part of the product and should be kept near the instrument for easy and quick reference
- The instrument shall not be used for purposes different from those described hereunder. It cannot be used as a safety device
- Check the application limits before proceeding
- Some parameters, such as CH are not applicable to Woodmaster see default settings grid fig. 15 on next page

#### 1.2 SAFETY PRECAUTIONS

- Check the supply voltage is correct before connecting the instrument
- Do not expose to water or moisture: use the controller only within the operating limits avoiding sudden temperature changes with high atmospheric humidity to prevent formation of condensation
- Warning: disconnect all electrical connections before any kind of maintenance
- Fit the probe where it is not accessible by the End User. The instrument must not be opened
- In case of failure or faulty operation send the instrument back to the distributor or to "Dixell s.r.l." (see address) with a detailed description of the fault
- Consider the maximum current, which can be applied to each relay (see Technical Data)
- Ensure that the wires for probes, loads and the power supply are separated and far enough from each other, without crossing or intertwining
- In case of applications in industrial environments, the use of mains filters (our mod. FT1) in parallel with inductive loads could be useful

### 2. GENERAL DESCRIPTION

Model XR30C, format 32 x 74 mm, is a digital thermostat. It provides two relay outputs, one for the fan, the other one for alarm signalling. The probe input can be selected between PTC or NTC. The instrument has a digital input, for alarm signalling, or for switching the auxiliary output.

### 3. CONTROLLING LOADS

#### 3.1 THE REGULATION OUTPUT

The regulation is performed according to the temperature measured by the probe.

The instruments are provided with the CH programmable parameter, which enables the user to set the regulation both for heating or cooling applications:

CH = Ht: heating applications, which is the application here.

#### 3.2 CH = HT: HEATING APPLICATION.

The Hy value is automatically set under the Set Point. If the temperature decreases and reaches set point minus differential the regulation output is activated and then turned off when the temperature reaches the set point value again.

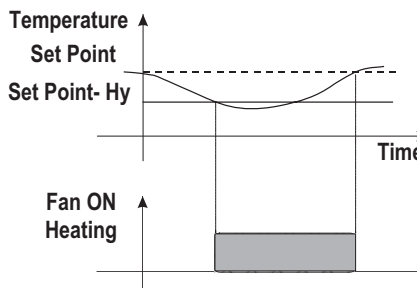

### 4. FRONT PANEL COMMANDS

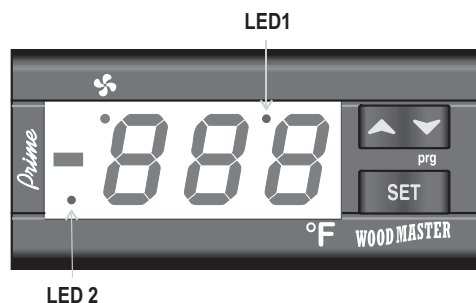

**SET:** Displays the target set point; selects and confirms a parameter in the programming mode. Also used in conjunction with **▲ (UP)** and **▼ (DOWN)** to view the Min and Max recorded temperatures and to reset the stored temperatures.

**▲ (UP):** To see the last temperature alarm that occurred; in programming mode it browses the parameter codes or increases the displayed value.

**▼ (DOWN)** To see the last temperature alarm that occurred; in programming mode it browses the parameter codes or decreases the displayed value.

#### KEY COMBINATIONS:

**▲ + ▼** To lock & unlock the keyboard.

**SET + ▼** To enter in programming mode.

**SET + ▲** To return to the temperature display.

### 4.1 USE OF LEDS

Each LED function is described in the following table.

| LED  | MODE     | FUNCTION   |
|------|----------|--|
|      | ON       | - Output enabled   |
|      | Flashing | - Programming Phase (flashing with LED1)<br>- Anti-short cycle delay enabled |
| LED1 | Flashing | - Programming Phase (flashing with )   |
| LED2 | ON       | - Temperature Alarm has happened, LED2 stays on until reset                  |

### 5. TEMPERATURE ALARM AND ITS DURATION

#### Example of Low temperature alarm

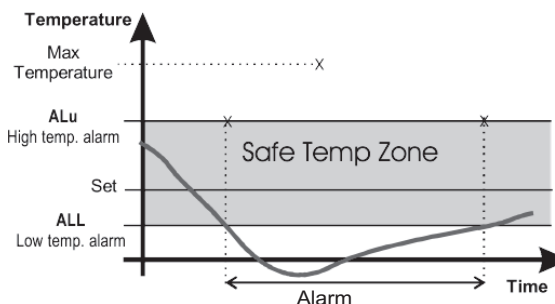



# E.T.C. Reference

## 5.1 HOW TO SEE THE ALARM DURATION AND MAX (MIN) TEMPERATURE

If the LED2, the alarm LED is on, an alarm has taken place

To see the kind of alarm, the max (min) reached temperature and alarm duration do as follows:

1. Push the Up or Down key.
2. On the display the following message is shown: "HAL" for high temperature alarm ("LAL" for the minimum alarm), followed by the **Maximum (minimum) temperature**. Then the "tiM" (tiMe) message is displayed, followed by the "Duration" in h.mm.
3. Then the instrument displays the temperature once again.

**NOTE1:** if an alarm is still occurring the "tim" shows the partial duration.

**NOTE2:** the alarm is recorded when the temperature comes back to normal values

## 5.2 HOW TO RESET A RECORDED ALARM OR ONE THAT IS STILL OCCURRING

1. Hold the SET key pressed for more than 3s, while the recorded alarm is displayed. (The rSt message will be displayed)
2. To confirm the operation, the "rSt" message starts blinking and the normal temperature will be displayed.

## 6. MAIN FUNCTIONS

### 6.1 HOW TO SEE THE SETPOINT

 Push and immediately release the **SET** key: the display will show the Set point value;

Push and immediately release the **SET** key or wait for 5 seconds to display the probe value again.

### 6.2 HOW TO CHANGE THE SETPOINT

1. Push the **SET** key for more than 2 seconds to change the Set point value;
2. The value of the set point will be displayed and the LED1 starts blinking;
3. To change the Set value push the  $\wedge$  or  $\vee$  arrows within 10s.
4. To memorise the new set point value push the **SET** key again or wait 10s.

### 6.3 HOW TO CHANGE A PARAMETER VALUE

To change the parameter's value operate as follows:

 Enter the Programming mode by pressing the Set and DOWN key for 3s  $\clubsuit$  and LED1 starts blinking.

-  SET
1. Select the required parameter.
  2. Press the "SET" key to display its value (only  $\clubsuit$  LED is blinking).
  3. Use "UP" or "DOWN" to change its value.
  4. Press "SET" to store the new value and move to the following parameter.

**To exit:** Press **SET + UP** or wait 15s without pressing a key.

**NOTE:** the set value is stored even when the procedure is exited by waiting the time-out to expire.

### 6.4 HOW TO LOCK THE KEYBOARD



1. Keep pressed for more than 3 s the  $\wedge$  and  $\vee$  keys.
2. The "POF" message will be displayed and the keyboard will be locked. At this point it will be possible only to see the set point or the MAX o Min temperature stored.
3. If a key is pressed more than 3s the "POF" message will be displayed.

### 6.5 TO UNLOCK THE KEYBOARD

Keep pressed together for more than 3s the  $\wedge$  and  $\vee$  keys, till the "Pon" message will be displayed.

## 7. PARAMETERS

### REGULATION

**Hy Differential:** (0,1 + 25,5°C / 1+255 °F) Intervention differential for set point. Fan Cut IN is Set Point Minus Differential (Hy). Fan Cut OUT is when the temperature reaches the set point.

### DISPLAY

**CF Temperature measurement unit:**

°C=Celsius; °F=Fahrenheit. **WARNING:** When the measurement unit is changed the SET point and the values of the parameters Hy, LS, US, Ot, ALU and ALL have to be checked and modified if necessary).

**rES Resolution (for °C):** (in = 1°C; dE = 0.1 °C) allows decimal point display.

### ALARM

**ALL Minimum temperature alarm:** (-50.0 + SET°C; 58+230°F when this temperature is reached the alarm is enabled and fan will shut off.

**AFH Differential for alarm recovery:** ((1+45 °F) It sets the value above the alarm value for alarm recovery.

## 8. ALARM SIGNALS

| Message | Cause                     | Outputs            |
|---------|---------------------------|--------------------|
| "LA"    | Minimum temperature alarm | Outputs unchanged. |

### 8.1 ALARM RECOVERY

Probe alarm "P1" starts some seconds after the fault in the related probe; it automatically stops some seconds after the probe restarts normal operation. Check connections before replacing the probe.

Temperature alarms "HA" and "LA" automatically stop as soon as the thermostat temperature returns to normal values.

Alarms "EA" and "CA" (with i1F=bAL) recover as soon as the digital input is disabled.

Alarm "CA" (with i1F=PAL) recovers only by **switching off and on** the instrument.

## 9. DEFAULT SETTING VALUES

| Label | Name                      | Range                 | °F  | Level |
|-------|---------------------------|-----------------------|-----|-------|
| Set   | Set point                 | LS+US                 | 170 | Pr1   |
| Hy    | Differential              | 0,1+25.5°C/ 1+ 255°F  | 10  | Pr1   |
| ALL   | Minimum temperature alarm | -50.0°C+Set/-58°F+Set | 120 | Pr1   |



e-211299



# E.T.C. Reference



Woody  
Woodmaster

## Changing E.T.C. Settings For units equipped with the XR30C

Note: The procedures are the same whether you are using degrees (F) or degrees (C).

### Changing the Set Point

1. Press and hold the set button for 3 seconds or until the fan symbol is flashing. The number that appeared is the Set Point. (Fig. 1)
2. Use the up or down arrow buttons to adjust the setting.
3. Press the set button to lock in the setting.

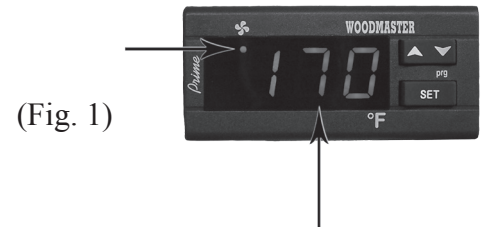

(Fig. 1)

### Changing the Hy

1. Press and hold the arrow down and set buttons until the display reads Hy. (Fig. 2)
2. Release the arrow down and set buttons.
3. Press set button, the number displayed is the differential. (Fig. 3)
4. Press the arrow up or down button to adjust. (Fig. 4)
5. Press the set button. (Fig. 5)
6. The display will read ALL for approximately 30 seconds, it will then return to the water temperature reading. (Fig. 6)



(Fig. 2)



(Fig. 3)



(Fig. 4)



(Fig. 5)



(Fig. 6)

### Changing the ALL

1. When the ETC reads ALL from the previous step, press the set button. The number that appears is the Low Alarm temperature.
2. To adjust the number press the up or down arrow.
3. Press the Set button to lock in the setting.

### Definitions

**Set Point-** The temperature at which the fan will shut down.

**Hy aka Differential-** The amount, in degrees, the temperature has to drop in order to start the fan.

**ALL- aka Low Alarm-** The temperature at which the furnace will shut down.



| WoodMaster Digital Aqua Stat Settings |        |         |
|---------------------------------------|--------|---------|
| Set Point (SP)                        | 170° F | 76.7° C |
| Differential (HY)                     | 10° F  | 5.5° C  |
| Low Alarm (ALL)                       | 120° F | 48.9° C |

### Factory Settings

| WoodMaster Digital Aqua Stat Minimum and Maximum Settings |                                      |
|---|--------------------------------------|
| Set Point (SP)  | 100° F to 180° F<br>38° C to 82° C   |
| Differential (HY)   | 1° F to 45° F<br>1° C to 25° C       |
| Low Alarm (ALL)   | -67° F to 302° F<br>-55° C to 150° C |



Woody  
Woodmaster

# E.T.C. Reference

## Digital custom controller XR30CX FOR WOODMASTER

### CONTENTS

|                                       |   |
|---------------------------------------|---|
| 1. GENERAL WARNING                    | 1 |
| 2. GENERAL DESCRIPTION                | 1 |
| 3. CONTROLLING LOADS                  | 1 |
| 4. FRONT PANEL COMMANDS               | 1 |
| 5. TEMPERATURE ALARM AND ITS DURATION | 1 |
| RECORDING (HACCP)                     | 1 |
| 6. MAIN FUNCTIONS                     | 2 |
| 7. PARAMETERS                         | 2 |
| 8. ALARM SIGNALS                      | 2 |
| 9. DEFAULT SETTING VALUES             | 2 |

### 1. GENERAL WARNING

#### 1.1 PLEASE READ BEFORE USING THIS MANUAL

- This manual is part of the product and should be kept near the instrument for easy and quick reference
- The instrument shall not be used for purposes different from those described hereunder. It cannot be used as a safety device
- Check the application limits before proceeding
- Some parameters, such as CH are not applicable to Woodmaster, see Section 9, Default Settings.

#### 1.2 SAFETY PRECAUTIONS

- Check the supply voltage is correct before connecting the instrument.
- Do not expose to water or moisture: use the controller only within the operating limits avoiding sudden temperature changes with high atmospheric humidity to prevent formation of condensation.
- Warning: disconnect all electrical connections before any kind of maintenance.
- Fit the probe where it is not accessible by the End User. The instrument must not be opened.
- In case of failure or faulty operation send the instrument back to the distributor or to "Dixell s.r.l." (see address) with a detailed description of the fault.
- Consider the maximum current which can be applied to each relay. (see Technical Data)
- Ensure that the wires for probes, loads and the power supply are separated and far enough from each other, without crossing or intertwining.
- In case of applications in industrial environments, the use of mains filters (our mod. FT1) in parallel with inductive loads could be useful.

### 2. GENERAL DESCRIPTION

Model XR30CX, format 32 x 74 mm, is a digital thermostat. It provides two relay outputs, one for the fan, the other one for alarm signalling. The probe input can be selected between PTC or NTC. The instrument has a digital input, for alarm signalling, or for switching the auxiliary output.

### 3. CONTROLLING LOADS

#### 3.1 THE REGULATION OUTPUT

The regulation is performed according to the temperature measured by the probe.

The instruments are provided with the CH programmable parameter, which enables the user to set the regulation both for heating or cooling applications:

CH = Ht: heating applications, which is the application here.

#### 3.2 CH = HT: HEATING APPLICATION.

The Hy value is automatically set under the Set Point. If the temperature decreases and reaches set point minus differential the regulation output is activated and then turned off when the temperature reaches the set point value again.

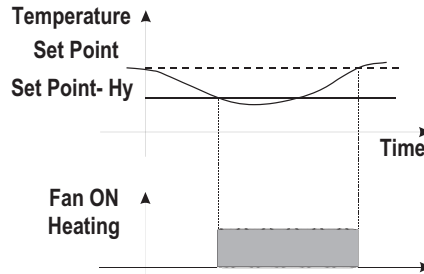

### 4. FRONT PANEL COMMANDS

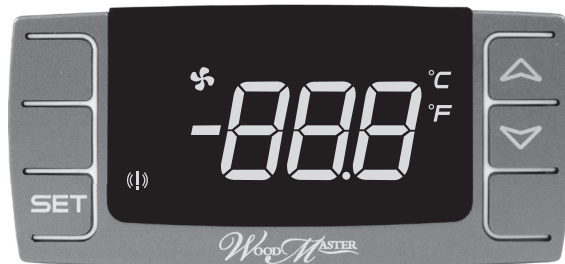

**SET:** Displays the target set point; selects and confirms a parameter in the programming mode. Also used in conjunction with **▲ (UP)** and **▼ (DOWN)** to view the Min and Max recorded temperatures and to reset the stored temperatures.

**▲ (UP):** To see the last temperature alarm that occurred; in programming mode it browses the parameter codes or increases the displayed value.

**▼ (DOWN)** To see the last temperature alarm that occurred; in programming mode it browses the parameter codes or decreases the displayed value.

#### KEY COMBINATIONS:

**▲ + ▼** To lock & unlock the keyboard.

**SET + ▼** To enter in programming mode.

**SET + ▲** To return to the temperature display.

### 4.1 USE OF LEDS

Each LED function is described in the following table.

| LED          | MODE     | FUNCTION  |
|--------------|----------|---|
|              | ON       | - Output enabled  |
|              | Flashing | - Anti-short cycle delay enabled                        |
| <b>°C/°F</b> | Flashing | - Programming Phase                                     |
|              | ON       | - Temperature Alarm has happened,  stays on until reset |

### 5. TEMPERATURE ALARM AND ITS DURATION

#### Example of Low temperature alarm

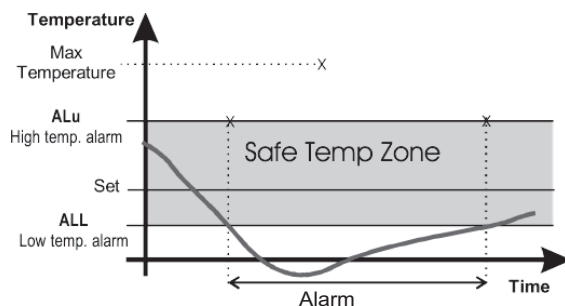



# E.T.C. Reference



Woody  
Woodmaster

## 5.1 HOW TO SEE THE ALARM DURATION AND MAX (MIN) TEMPERATURE

If the alarm LED is on, an alarm has taken place

To see the kind of alarm, the max (min) reached temperature and alarm duration do as follows:

1. Push the Up or Down key.
2. On the display the following message is shown: "HAL" for high temperature alarm ("LAL" for the minimum alarm), followed by the **Maximum (minimum) temperature**. Then the "tiM" (tiMe) message is displayed, followed by the "Duration" in h.mm.
3. Then the instrument displays the temperature once again.

**NOTE1:** if an alarm is still occurring the "tim" shows the partial duration.

**NOTE2:** the alarm is recorded when the temperature comes back to normal values.

## 5.2 HOW TO RESET A RECORDED ALARM OR ONE THAT IS STILL OCCURRING

1. Hold the SET key pressed for more than 3s, while the recorded alarm is displayed. (The rSt message will be displayed)
2. To confirm the operation, the "rSt" message starts blinking and the normal temperature will be displayed.

## 6. MAIN FUNCTIONS

### 6.1 HOW TO SEE THE SETPOINT

SET  Push and immediately release the SET key: the display will show the Set point value;

Push and immediately release the SET key or wait for 5 seconds to display the probe value again.

### 6.2 HOW TO CHANGE THE SETPOINT

1. Push the SET key for more than 2 seconds to change the Set point value;
2. The value of the set point will be displayed and the "C" or "F" starts blinking;
3. To change the Set value push the ^ or v arrows within 10s.
4. To memorize the new set point value push the SET key again or wait 10s.

### 6.3 HOW TO CHANGE A PARAMETER VALUE

To change the parameter's value operate as follows:

1. Enter the Programming mode by pressing Set and v keys for three seconds. (the "C" or "F" LED start blinking)
2. Select the required parameter. Press the SET key to display its value.
3. Use "UP" or "DOWN" to change its value.
4. Press "SET" to store the new value and move to the following parameter.

**To exit:** Press SET + UP or wait 15s without pressing a key.

**NOTE:** the set value is stored even when the procedure is exited by waiting the time-out to expire.

### 6.4 HOW TO LOCK THE KEYBOARD



1. Keep pressed for more than 3 s the ^ and v keys.
2. The "POF" message will be displayed and the keyboard will be locked. At this point it will be possible only to see the set point or the MAX o Min temperature stored.
3. If a key is pressed more than 3s the "POF" message will be displayed.

## 6.5 TO UNLOCK THE KEYBOARD

Keep pressed together for more than 3s the ^ and v keys, till the "Pon" message will be displayed.

## 7. PARAMETERS

### REGULATION

**Hy Differential:** (0,1 ÷ 25,5°C / 1÷255 °F) Intervention differential for set point. Fan Cut IN is Set Point Minus Differential (Hy). Fan Cut OUT is when the temperature reaches the set point.

### DISPLAY

**CF Temperature measurement unit:**

°C=Celsius; °F=Fahrenheit. **WARNING:** When the measurement unit is changed the SET point and the values of the parameters Hy, LS, US, Ot, ALU and ALL have to be checked and modified if necessary).

**rES Resolution (for °C):** (in = 1°C; dE = 0.1 °C) allows decimal point display.

**dLy Display Delay:** (0 ÷20.0m; risul. 10s) when the temperature increases, the display is updated of 1°C/1°F after this time.

### ALARM

**ALL Minimum temperature alarm:** (-50.0 ÷ SET°C; 58÷230°F when this temperature is reached the alarm is enabled and fan will shut off.

**AFH Differential for alarm recovery:** ((1÷45 °F) It sets the value above the alarm value for alarm recovery.

## 8. ALARM SIGNALS

| Message | Cause                     | Outputs            |
|---------|---------------------------|--------------------|
| "LA"    | Minimum temperature alarm | Outputs unchanged. |

### 8.1 ALARM RECOVERY

Probe alarm "P1" starts some seconds after the fault in the related probe; it automatically stops some seconds after the probe restarts normal operation. Check connections before replacing the probe.

Temperature alarms "HA" and "LA" automatically stop as soon as the thermostat temperature returns to normal values.

Alarms "EA" and "CA" (with i1F=bAL) recover as soon as the digital input is disabled.

Alarm "CA" (with i1F=PAL) recovers only by **switching off and on** the instrument.

## 9. DEFAULT SETTING VALUES

| Label | Name                      | Range                 | °F  | Level |
|-------|---------------------------|-----------------------|-----|-------|
| Set   | Set point                 | LS+US                 | 170 | Pr1   |
| Hy    | Differential              | 0,1÷25.5°C/ 1÷ 255°F  | 10  | Pr1   |
| ALL   | Minimum temperature alarm | -50.0°C+Set/-58°F+Set | 120 | Pr1   |



e-211299



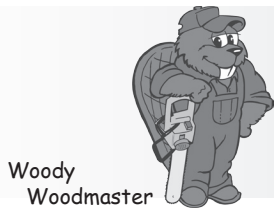

# E.T.C. Reference

## Changing E.T.C. Settings

For units equipped with the XR30CX

Note: The procedures are the same whether you are using degrees (F) or degrees (C).

### Changing the Set Point

1. Press and hold the set button for 3 seconds or until the °C/°F is flashing. The number that appears is the Set Point. (Fig. 1)
2. Use the up or down arrow buttons to adjust the setting.
3. Press the set button to lock in the settings.

(Fig. 1)

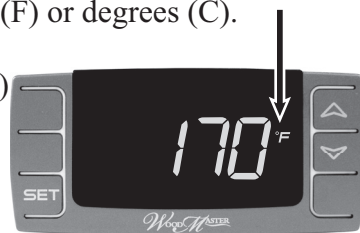

### Changing the Hy

1. Press and hold the down arrow and set buttons until the display reads Hy. (Fig. 2)
3. Press set button, the number displayed is the differential. (Fig. 3)
2. Release the arrow down and set buttons.
4. Press the arrow up or down button to adjust. (Fig. 4)
5. Press the set button. (Fig. 5)
6. The display will read ALL for approximately 30 seconds, (Fig. 5) it will then return to the water temperature reading. (Fig. 6)

(Fig. 2)



(Fig. 3)



(Fig. 4)



(Fig. 5)



(Fig. 6)



### Changing the All

1. When the E.T.C. reads ALL from the previous step press the set -button. The number that appears is the Low Alarm temperature.
2. To adjust the number press the up or down arrow.
3. Press the Set button to lock in the setting.

### Definitions

**Set Point-** The temperature at which the fan will shut down, until hysteresis is achieved.

**Hy aka Differential-** The amount, in degrees, the temperature has to drop in order to start the fan.

**ALL aka Low Alarm-** The temperature at which the furnace will shut down. At which point the furnace should be reloaded and the control is reset.

**Note:** The temperature scale can be changed from Fahrenheit to Celsius with the hot key from your WoodMaster Dealer.

#### **CAUTION!!**

Do not set your (SP) lower than your (ALL)!

#### **WoodMaster Digital Aqua Stat Factory Settings**

|                   |        |        |
|-------------------|--------|--------|
| Set Point (SP)    | 170° F | 76.7°C |
| Differential (HY) | 10° F  | 5.5°C  |
| Low Alarm (ALL)   | 120° F | 48.9°C |

#### **WoodMaster Digital Aqua Stat Minimum and Maximum Factory Settings**

|                   |                                      |
|-------------------|--------------------------------------|
| Set Point (SP)    | 100° F to 180° F<br>38° C to 82° C   |
| Differential (HY) | 1° F to 45° F<br>1° C to 25° C       |
| Low Alarm (ALL)   | -67° F to 302° F<br>-55° C to 150° C |

# Wiring Diagrams



Woody  
Woodmaster

AQUA STAT HARNESS – 02/07/2008

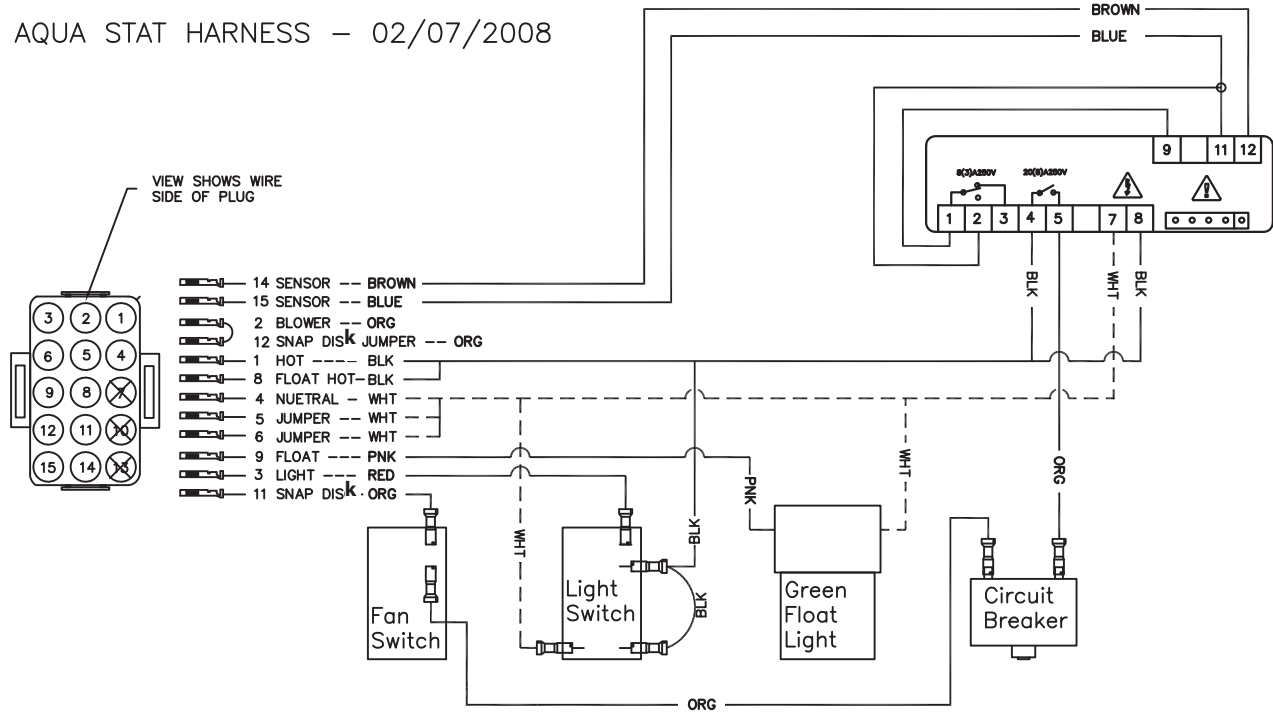

STOVE HARNESS – 02/07/2008

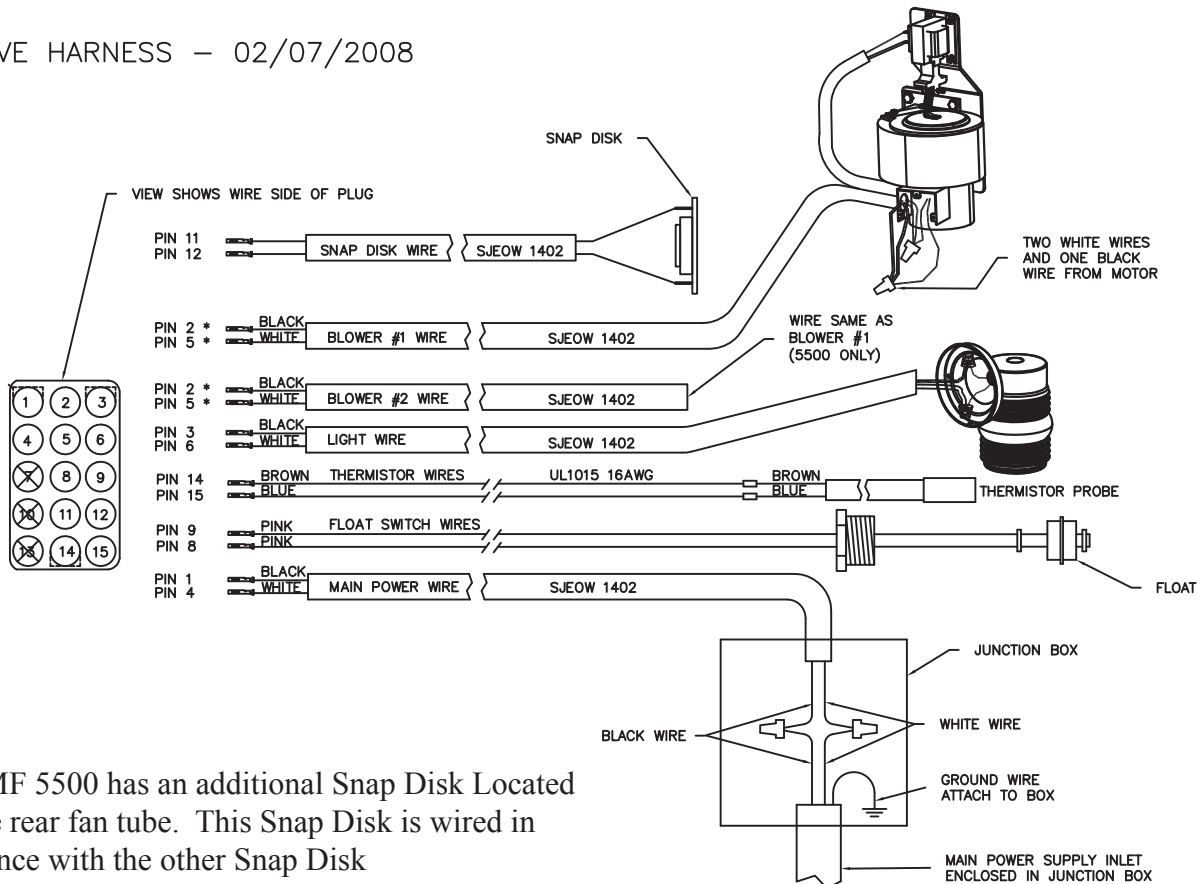

Note: The MF 5500 has an additional Snap Disk Located on the rear fan tube. This Snap Disk is wired in sequence with the other Snap Disk



Woody  
Woodmaster

# Technical Specifications & Slab Dimensions

| Specification                              | 3300  | 4400  | 5500  | 6500  |
|--|---|---|---|---|
| Water Capacity                             | 105 Gallons                                       | 117 Gallons   | 194 Gallons   | 487 Gallons   |
| Amp. Draw<br>@ 120v AC, 60 Hz              | Max- 6 Amp *<br>Idle- .5 Amp<br>Avg. Running- 1.5 | Max- 6.9 Amp *<br>Idle- .5 Amp<br>Avg. Running- 2.5 | Max- 7.5 Amp *<br>Idle- .5 Amp<br>Avg. Running- 3.5 | Max- 19.8 Amp *<br>Idle- .5 Amp<br>Avg. Running- 6.41 |
| Heating Capacity                           | 2000 sq. ft. <sup>1</sup>                         | 5000 sq. ft. <sup>1</sup>                           | 10,000 sq. ft. <sup>1</sup>                         | 20,000 sq. ft. <sup>1</sup>                           |
| Firebox Dimensions                         | 34" x 32"   | 38" x 44"   | 50" x 56"   | 60" x 58"   |
| Weight of Furnace filled<br>with water     | 2292 lb.  | 2784 lb.  | 4450 lb.  | 7789 lb.  |
| Loading Door Opening<br>Outside Dimensions | 20" x 21"   | 24" x 24"   | 27" x 27"   | 44" x 31"   |

\* Amp draw may vary depending on the revision of your furnace and external devices attached to your furnace.  
Maximum Amp Draw can only occur when all devices are operating, this only happens momentarily at the start up.

<sup>1</sup> Actual results will vary depending on the system, applications and insulation values.

**3300 Slab Dimensions**

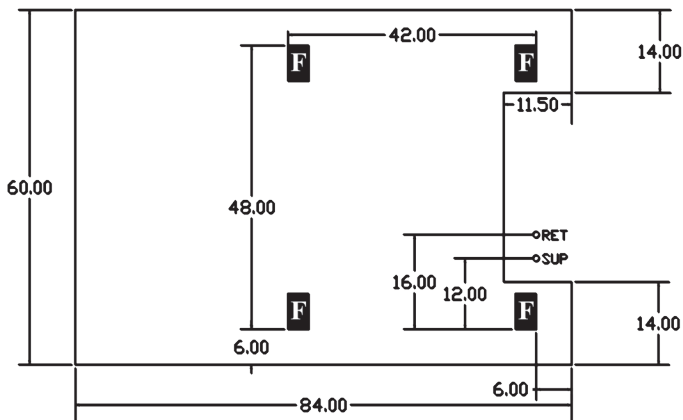

**4400 Slab Dimensions**

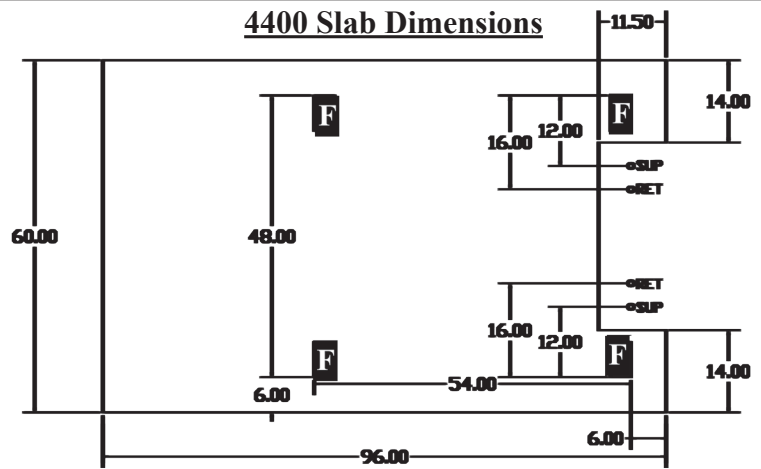

**5500 Slab Dimensions**

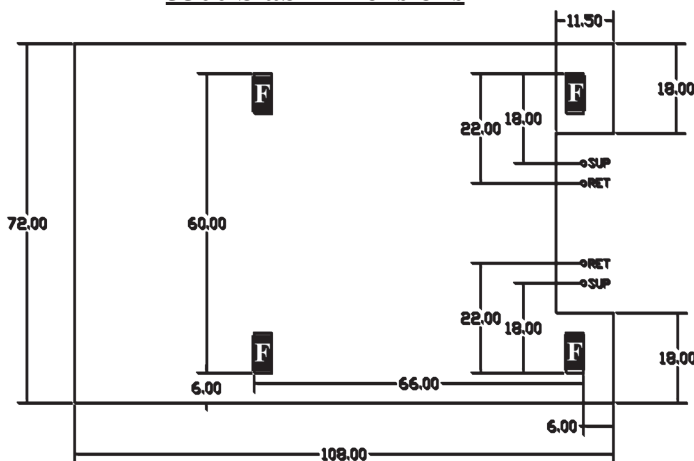

**6500 Slab Dimensions**

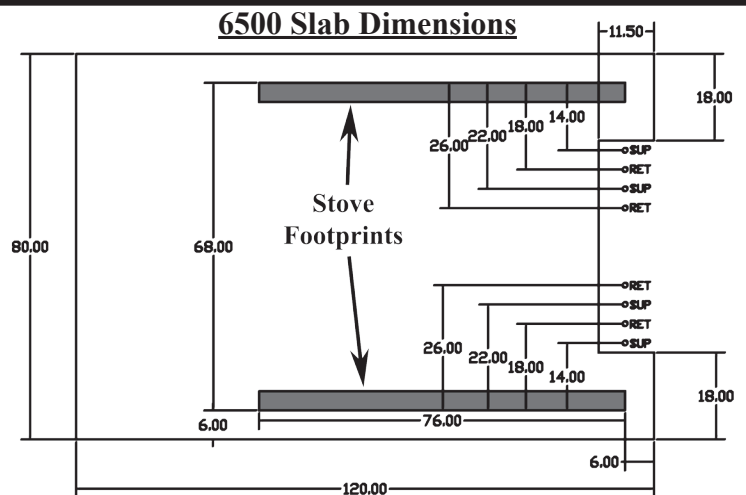

F= Stove Footprint



# WoodMaster Limited Lifetime Warranty

3300/4400/5500/6500

## NORTHWEST MANUFACTURING, INC.

600 Polk Ave. SW – Red Lake Falls, MN 56750

Toll free (800) 932-3629 or (218) 253-4328

### Limited Lifetime Warranty on Fire Drum and Water Jacket

Northwest Manufacturing, Inc. of Red Lake Falls, MN 56750 warrants material and labor on any defects in workmanship on the Fire drum and Water Jacket for a period of ten years from the purchase date to the original owner only. If there is a leak in your properly delivered and installed WoodMaster furnace in the first year, WoodMaster will replace the furnace at no cost to the original owner. (A leak means; a leak in the firebox or water jacket.) Northwest Manufacturing, Inc. will not be responsible for environmental conditions we cannot control. Therefore, Northwest Manufacturing, Inc. will only pay these percentages of costs of warranty work per year, years two (2) through five (5) – 100% of warranty work, the sixth (6) year – 70% of warranty work, the seventh (7) year – 60% of warranty work, the eight (8) year – 40% of warranty work, the ninth (9) year – 20% of warranty work, the tenth (10) year – 10% of warranty work. Years eleven through twenty (11-20) WoodMaster will give you a 10% discount on the purchase of a new WoodMaster furnace. (furnace only) Years twenty-one (21) and beyond WoodMaster will give you a 5% discount on the purchase of a new WoodMaster furnace. (furnace only)

**WARNING:** Northwest Manufacturing, Inc. **will not** warranty the inside of fire drum due to ash corrosion. Rotation of ashes must be taken care of as displayed on the maintenance list, located on the side of the furnace. The fire drum must be completely cleaned of all ashes and creosote a minimum of two (2) times per year, preferably half way through the heating season and immediately after the heating season. The chimney must be covered when the furnace is not in use. If antifreeze is not being used the water jacket must be drained and flushed yearly after each heating season. After the furnace has been drained, immediately refill completely and treat with new boiler treatment.

### Two Year Warranty – Parts and Labor

Northwest Manufacturing, Inc. warrants to the original owner only, any electrical components in the furnace that is defective during normal usage for a period of two (2) years from the date of purchase.

Northwest Manufacturing, Inc. warrants to the original owner only, any defects in materials or workmanship to the front door of the furnace for a period of two (2) years from the date of purchase.

Northwest Manufacturing, Inc. warrants to the original owner only, any defects in materials or workmanship to the stainless steel chimney on the furnace itself for a period of two (2) years from the date of purchase.

These warranties apply only if the device is installed and operated as defined in the Owner's Manual.

Your dealer may charge you for a service call to do warranty work. Parts will be replaced on an even exchange basis.

WoodMaster outdoor wood furnaces are not intended to be the only source of heat; therefore a backup system should be in place to prevent any damage caused by lack of heat.

Damage caused by abuse, accidents, improper installation, overheating, corrosion, freezing or negligence will not be covered under warranty. Damage caused by burning flammable materials (such as petroleum products) will not be covered under warranty.

This warranty is limited to defective parts – repair and/or replacement only, and excludes any incidental and consequential damages connected therewith. Northwest Manufacturing, Inc. is not responsible for replacement of water, water treatment, antifreeze, costs of transportation, or shipping charges. On-site service work will be offered to you. Please call Northwest Manufacturing, Inc. for current non-warranty rates.

**Antifreeze** – Only nontoxic antifreeze is acceptable. Antifreeze will break down over a period of time and therefore should be tested annually. Always dispose of antifreeze by state and local codes. Loss of antifreeze under any condition will not be covered.

**How to file a claim** – ANY CLAIM UNDER THIS WARRANTY **MUST BE MADE TO YOUR DEALER.**

### Auger Stove Supplement – One Year Limited Warranty

#### This warranty is in addition to the warranty on your WoodMaster

Northwest Manufacturing, Inc. warrants to the original owner only, material and labor on any defects in workmanship, on ash auger removable parts, including grate and auger for one (1) year from the date of purchase. Removable ash auger parts are considered and designed to be consumable parts. Grates and augers may warp due to high heat or deteriorate over time and will have to be adjusted or replaced. This warranty will not cover warped grates or augers, nor cover deterioration due to ash corrosion. Ash auger stove modification such as the auger tube, which is welded to the stove, will carry the normal stove warranty. This warranty is limited to defective parts – repair and/or replacement only – and excludes any incidental or consequential damage connected therewith. Northwest Manufacturing, Inc. is not responsible for replacement of water, water treatment, anti-freeze, and cost of transportation or shipping charges. Once a year this Auger System must be removed from the furnace and the furnace completely cleaned out. Refer to the WoodMaster Owner's Manual for Maintenance Procedures.

Customer's Name \_\_\_\_\_ Dealer's Name \_\_\_\_\_

Customer's Signature \_\_\_\_\_ Dealer's Signature \_\_\_\_\_

OWNER'S REGISTRATION CARD

Name \_\_\_\_\_

Installed by:  Dealer  Customer

Address \_\_\_\_\_

If customer, was installation explained to you?

\_\_\_\_\_

Yes  No

Phone \_\_\_\_\_

Type of Installation:

Date of Purchase \_\_\_\_\_

House/Garage  Shop/Shed

Model No. \_\_\_\_\_

Greenhouse  Kiln

Serial No. \_\_\_\_\_

(Model and serial numbers are located on the decal on front of furnace.)

Other \_\_\_\_\_

Purchased:

Dealer's Name \_\_\_\_\_

With Auger  Without Auger

Northwest Manufacturing Inc.  
600 Polk Ave. SW  
Red Lake Falls, MN 56750

PLACE  
POSTAGE  
HERE

Northwest Manufacturing Inc.  
600 Polk Ave. SW  
Red Lake Falls, MN 56750

# WoodMaster Limited Lifetime Warranty

3300/4400/5500/6500

## NORTHWEST MANUFACTURING, INC.

600 Polk Ave. SW – Red Lake Falls, MN 56750

Toll free (800) 932-3629 or (218) 253-4328

### Limited Lifetime Warranty on Fire Drum and Water Jacket

Northwest Manufacturing, Inc. of Red Lake Falls, MN 56750 warrants material and labor on any defects in workmanship on the Fire drum and Water Jacket for a period of ten years from the purchase date to the original owner only. If there is a leak in your properly delivered and installed WoodMaster furnace in the first year, WoodMaster will replace the furnace at no cost to the original owner. (A leak means; a leak in the firebox or water jacket.) Northwest Manufacturing, Inc. will not be responsible for environmental conditions we cannot control. Therefore, Northwest Manufacturing, Inc. will only pay these percentages of costs of warranty work per year, years two (2) through five (5) – 100% of warranty work, the sixth (6) year – 70% of warranty work, the seventh (7) year – 60% of warranty work, the eight (8) year – 40% of warranty work, the ninth (9) year – 20% of warranty work, the tenth (10) year – 10% of warranty work. Years eleven through twenty (11-20) WoodMaster will give you a 10% discount on the purchase of a new WoodMaster furnace. (furnace only) Years twenty-one (21) and beyond WoodMaster will give you a 5% discount on the purchase of a new WoodMaster furnace. (furnace only)

**WARNING:** Northwest Manufacturing, Inc. **will not** warranty the inside of fire drum due to ash corrosion. Rotation of ashes must be taken care of as displayed on the maintenance list, located on the side of the furnace. The fire drum must be completely cleaned of all ashes and creosote a minimum of two (2) times per year, preferably half way through the heating season and immediately after the heating season. The chimney must be covered when the furnace is not in use. If antifreeze is not being used the water jacket must be drained and flushed yearly after each heating season. After the furnace has been drained, immediately refill completely and treat with new boiler treatment.

### Two Year Warranty – Parts and Labor

Northwest Manufacturing, Inc. warrants to the original owner only, any electrical components in the furnace that is defective during normal usage for a period of two (2) years from the date of purchase.

Northwest Manufacturing, Inc. warrants to the original owner only, any defects in materials or workmanship to the front door of the furnace for a period of two (2) years from the date of purchase.

Northwest Manufacturing, Inc. warrants to the original owner only, any defects in materials or workmanship to the stainless steel chimney on the furnace itself for a period of two (2) years from the date of purchase.

These warranties apply only if the device is installed and operated as defined in the Owner's Manual.

Your dealer may charge you for a service call to do warranty work. Parts will be replaced on an even exchange basis.

WoodMaster outdoor wood furnaces are not intended to be the only source of heat; therefore a backup system should be in place to prevent any damage caused by lack of heat.

Damage caused by abuse, accidents, improper installation, overheating, corrosion, freezing or negligence will not be covered under warranty. Damage caused by burning flammable materials (such as petroleum products) will not be covered under warranty.

This warranty is limited to defective parts – repair and/or replacement only, and excludes any incidental and consequential damages connected therewith. Northwest Manufacturing, Inc. is not responsible for replacement of water, water treatment, antifreeze, costs of transportation, or shipping charges. On-site service work will be offered to you. Please call Northwest Manufacturing, Inc. for current non-warranty rates.

**Antifreeze** – Only nontoxic antifreeze is acceptable. Antifreeze will break down over a period of time and therefore should be tested annually. Always dispose of antifreeze by state and local codes. Loss of antifreeze under any condition will not be covered.

**How to file a claim** – ANY CLAIM UNDER THIS WARRANTY **MUST BE MADE TO YOUR DEALER.**

### Auger Stove Supplement – One Year Limited Warranty

#### This warranty is in addition to the warranty on your WoodMaster

Northwest Manufacturing, Inc. warrants to the original owner only, material and labor on any defects in workmanship, on ash auger removable parts, including grate and auger for one (1) year from the date of purchase. Removable ash auger parts are considered and designed to be consumable parts. Grates and augers may warp due to high heat or deteriorate over time and will have to be adjusted or replaced. This warranty will not cover warped grates or augers, nor cover deterioration due to ash corrosion. Ash auger stove modification such as the auger tube, which is welded to the stove, will carry the normal stove warranty. This warranty is limited to defective parts – repair and/or replacement only – and excludes any incidental or consequential damage connected therewith. Northwest Manufacturing, Inc. is not responsible for replacement of water, water treatment, anti-freeze, and cost of transportation or shipping charges. Once a year this Auger System must be removed from the furnace and the furnace completely cleaned out. Refer to the WoodMaster Owner's Manual for Maintenance Procedures.

Customer's Name \_\_\_\_\_ Dealer's Name \_\_\_\_\_

Customer's Signature \_\_\_\_\_ Dealer's Signature \_\_\_\_\_

OWNER'S REGISTRATION CARD

Name \_\_\_\_\_

Installed by:  Dealer  Customer

Address \_\_\_\_\_

If customer, was installation explained to you?

\_\_\_\_\_

Yes  No

Phone \_\_\_\_\_

Type of Installation:

Date of Purchase \_\_\_\_\_

House/Garage  Shop/Shed  
 Greenhouse  Kiln  
 Other \_\_\_\_\_

Model No. \_\_\_\_\_

Serial No. \_\_\_\_\_

(Model and serial numbers are located on the decal on front of furnace.)

Purchased:  With Auger  Without Auger

Dealer's Name \_\_\_\_\_

Northwest Manufacturing Inc.  
600 Polk Ave. SW  
Red Lake Falls, MN 56750

PLACE  
POSTAGE  
HERE

Northwest Manufacturing Inc.  
600 Polk Ave. SW  
Red Lake Falls, MN 56750



# Warranty



## WoodMaster Limited Lifetime Warranty

**3300/4400/5500/6500**

### NORTHWEST MANUFACTURING, INC.

600 Polk Ave. SW – Red Lake Falls, MN 56750

Toll free (800) 932-3629 or (218) 253-4328

### **Limited Lifetime Warranty on Fire Drum and Water Jacket**

Northwest Manufacturing, Inc. of Red Lake Falls, MN 56750 warrants material and labor on any defects in workmanship on the Fire drum and Water Jacket for a period of ten years from the purchase date to the original owner only. If there is a leak in your properly delivered and installed WoodMaster furnace in the first year, WoodMaster will replace the furnace at no cost to the original owner. (A leak means; a leak in the firebox or water jacket.) Northwest Manufacturing, Inc. will not be responsible for environmental conditions we cannot control. Therefore, Northwest Manufacturing, Inc. will only pay these percentages of costs of warranty work per year, years two (2) through five (5) – 100% of warranty work, the sixth (6) year – 70% of warranty work, the seventh (7) year – 60% of warranty work, the eight (8) year – 40% of warranty work, the ninth (9) year – 20% of warranty work, the tenth (10) year – 10% of warranty work. Years eleven through twenty (11-20) WoodMaster will give you a 10% discount on the purchase of a new WoodMaster furnace. (furnace only) Years twenty-one (21) and beyond WoodMaster will give you a 5% discount on the purchase of a new WoodMaster furnace. (furnace only)

**WARNING:** Northwest Manufacturing, Inc. **will not** warranty the inside of fire drum due to ash corrosion. Rotation of ashes must be taken care of as displayed on the maintenance list, located on the side of the furnace. The fire drum must be completely cleaned of all ashes and creosote a minimum of two (2) times per year, preferably half way through the heating season and immediately after the heating season. The chimney must be covered when the furnace is not in use. If antifreeze is not being used the water jacket must be drained and flushed yearly after each heating season. After the furnace has been drained, immediately refill completely and treat with new boiler treatment.

### **Two Year Warranty – Parts and Labor**

Northwest Manufacturing, Inc. warrants to the original owner only, any electrical components in the furnace that is defective during normal usage for a period of two (2) years from the date of purchase.

Northwest Manufacturing, Inc. warrants to the original owner only, any defects in materials or workmanship to the front door of the furnace for a period of two (2) years from the date of purchase.

Northwest Manufacturing, Inc. warrants to the original owner only, any defects in materials or workmanship to the stainless steel chimney on the furnace itself for a period of two (2) years from the date of purchase.

These warranties apply only if the device is installed and operated as defined in the Owner's Manual.

Your dealer may charge you for a service call to do warranty work. Parts will be replaced on an even exchange basis.

WoodMaster outdoor wood furnaces are not intended to be the only source of heat; therefore a backup system should be in place to prevent any damage caused by lack of heat.

Damage caused by abuse, accidents, improper installation, overheating, corrosion, freezing or negligence will not be covered under warranty. Damage caused by burning flammable materials (such as petroleum products) will not be covered under warranty.

This warranty is limited to defective parts – repair and/or replacement only, and excludes any incidental and consequential damages connected therewith. Northwest Manufacturing, Inc. is not responsible for replacement of water, water treatment, antifreeze, costs of transportation, or shipping charges. On-site service work will be offered to you. Please call Northwest Manufacturing, Inc. for current non-warranty rates.

**Antifreeze** – Only nontoxic antifreeze is acceptable. Antifreeze will break down over a period of time and therefore should be tested annually. Always dispose of antifreeze by state and local codes. Loss of antifreeze under any condition will not be covered.

**How to file a claim** – ANY CLAIM UNDER THIS WARRANTY MUST BE MADE TO YOUR DEALER.

### **Auger Stove Supplement – One Year Limited Warranty**

#### **This warranty is in addition to the warranty on your WoodMaster**

Northwest Manufacturing, Inc. warrants to the original owner only, material and labor on any defects in workmanship, on ash auger removable parts, including grate and auger for one (1) year from the date of purchase. Removable ash auger parts are considered and designed to be consumable parts. Grates and augers may warp due to high heat or deteriorate over time and will have to be adjusted or replaced. This warranty will not cover warped grates or augers, nor cover deterioration due to ash corrosion. Ash auger stove modification such as the auger tube, which is welded to the stove, will carry the normal stove warranty. This warranty is limited to defective parts – repair and/or replacement only – and excludes any incidental or consequential damage connected therewith. Northwest Manufacturing, Inc. is not responsible for replacement of water, water treatment, anti-freeze, and cost of transportation or shipping charges. Once a year this Auger System must be removed from the furnace and the furnace completely cleaned out. Refer to the WoodMaster Owner's Manual for Maintenance Procedures.

*W*OOD  
*M*ASTER®