



30⁺
HOURS
BURN TIME

Regency F5100

Extra Large Hybrid Catalytic Wood Stove
Featuring Eco-Boost Technology

EPA
APPROVED

85%
EFFICIENCY

22"
MAX. LOG SIZE

180
SQ. IN. VIEW AREA

90lbs
MAX. WOOD LOAD

4.42
CU. FT. FIREBOX

CAST
IRON DURABILITY

The Largest EPA Wood Stove Available In North America

You don't have to sacrifice *style* anymore.

The Regency F5100 Extra Large Wood Stove lets you enjoy the impressive heat performance of Regency's largest classic wood stove with today's clean modern styling. This catalytic wood stove delivers both function and style that features sleek lines, a contemporary door design and large clean viewing area of a roaring wood fire.

A broad heating *range* means flexibility.

The loading capacity combined with the controllable burn rate of our Eco-Boost technology provides flexibility to heat smaller homes with less reloading and large homes with the maximum capacity available.



Hybrid Catalytic Technology

The catalytic combustor permits the wood stove to burn slowly delivering 30 hours of heat or more* with a single load of wood. Fuel is utilized to its full potential with only 1.46 g/hr of emissions and **85.48%** efficiency!



Burn All Day & All Night

At 4.42 cu. ft. the F5100 is the largest firebox available! Load up to 90 lbs of wood at a time for 30+ hours* of consistent, reliable heat. Convenient loading of 22" logs north to south and east to west.



Easy Single-Lever Operation

A simple single-lever air control conveniently located at the front of the stove can be adjusted to meet home heat requirements, from a hot burn to a smoldering glow that just keeps the chill away.



Large View Cast Iron Door

A heavy duty cast iron door offers 180 square inches viewing area delivering an excellent view of the roaring fire. The door opens to 170° making wood loading easy!

Lifetime Warranty

With over 30 years of wood stove manufacturing expertise, along with the most comprehensive warranty in the industry, the F5100 is guaranteed to deliver a lifetime of dependable heat. The catalytic combustor is covered for the first six years. Consult the manual for complete details.



Standard Features

- Catalytic Stove with Eco-Boost Technology
- 4.42 cu. ft firebox accommodating 22" logs
- Single lever bypass control to engage catalyst
- Single-lever air control to adjust heat output
- Brick-lined firebox
- Rear heat deflector
- Airwash system helps keep the glass clean
- Discreet ashlip
- Contemporary cast iron door in black with 180 sq inch viewing area
- 170 degree opening door for easy loading

Optional Features

- Extra large ash drawer with cover
- Two-speed blower
- Convector airmate
- Outside air kit

Technology	Custom designed Eco-Boost technology (developed in 2012)
Heating capacity	1,500 - 3,000 sq. ft. **
Firebox capacity	4.42 cu. Ft.
Maximum wood load	90 lbs ***
Maximum BTUs per load	765,000 ***
BTU output range	12,000 - 80,000 BTUs
Log size (front-to-back)	22 in.
Log size (side to side)	22 in.
Emissions	1.46 g/hr
Weight	520 lbs
Efficiency	85.48%
Door	25 in. W x 16 in. H 37.6 lbs heavy cast iron
Viewing area	180 sq. in.
Loading opening	20.125 in. W x 10 in. H
Blower (optional)	125 CFM
Bypass assembly	heavy cast iron
Air control	single lever, easy front access
Firebox construction	heavy duty 3/16" steel
Ash pan (optional) capacity	0.55 sq. ft.
Positive cam latching system	yes

* Length of burn time and BTU output depend upon wood species used, moisture content of wood, elevation, climate conditions and installation.

** Varies depending on home floor plan, house layout, heat loss of the house and quality/moisture content of wood.

*** Based on 8,500 BTU's per lbs.

Eco-Boost Technology

Secondary Air Tube

The secondary air tube, working with the catalyst, ensures the fuel is burned to its full potential resulting in low emissions and high heat output.

Catalytic Combustor

Helps create consistent heat by slowly burning unused fuel that would normally go up the chimney as smoke.

Heavy Duty Stainless Steel Flame Shield

Provides better distribution of gases over the catalyst and protects the catalyst from direct flame exposure.

Air Wash System

Helps keep the glass clean and provides an excellent view of the roaring fire.

Single Lever Air Control

Easily controls the heat output and size of the fire by adjusting the amount of air intake.

Extra Large Optional Ash Drawer

The largest concealed ash drawer that allows for easy clean up.

Convactor Airmate

Optional airmate to help direct warm air further into the room.

Simple Temperature Thermometer

The easy to read thermometer indicates when to close the bypass lever and engage catalytic activity.

Cast Iron Bypass Damper

Is used to close the damper and engage the catalytic combustor.

Blower

The 2-speed blower quickly distributes heat throughout the room.

Room Air

Air from the room is drawn in through the bottom of the stove for the primary and secondary combustion.

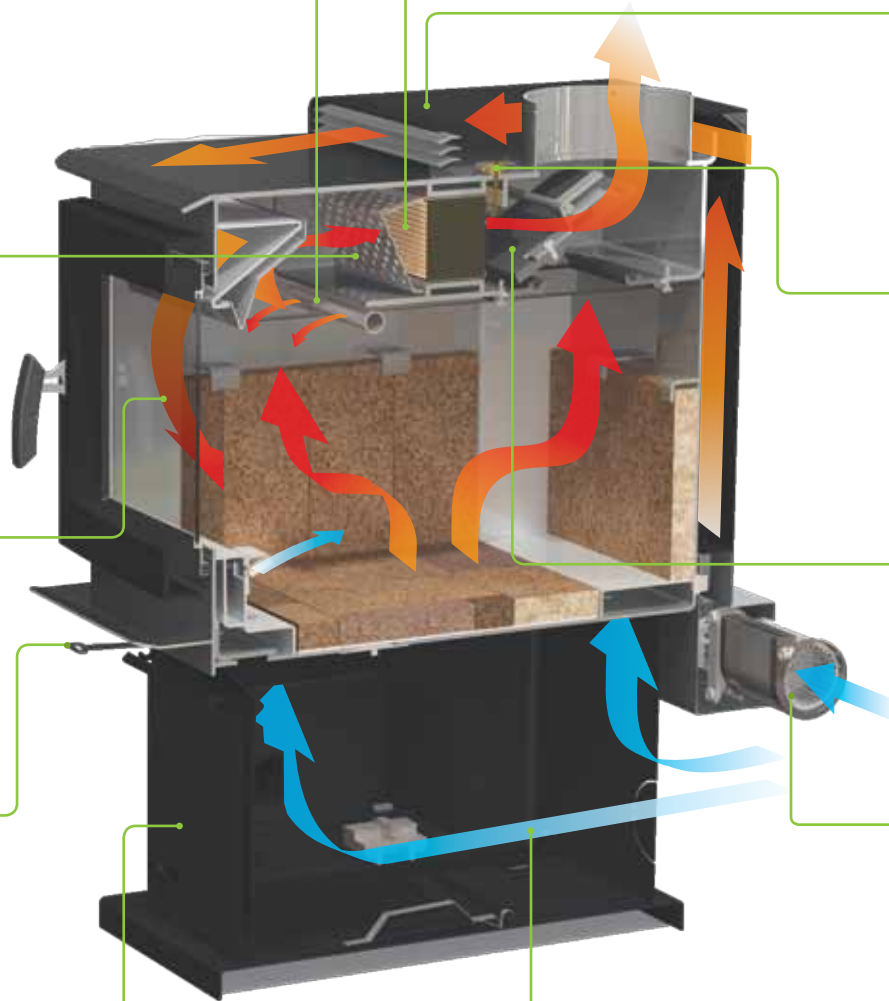

How does Eco-Boost *work*?

A heavy duty, secondary air tube is strategically placed to ensure maximized re-burn of products of combustion before making their way to the combustor. Serving as a pre-filter, the Eco-Boost system maximizes efficiency and prolongs the life of the catalytic combustor by decreasing its exposure to harmful combustion substances.



Specifications

Dimensions

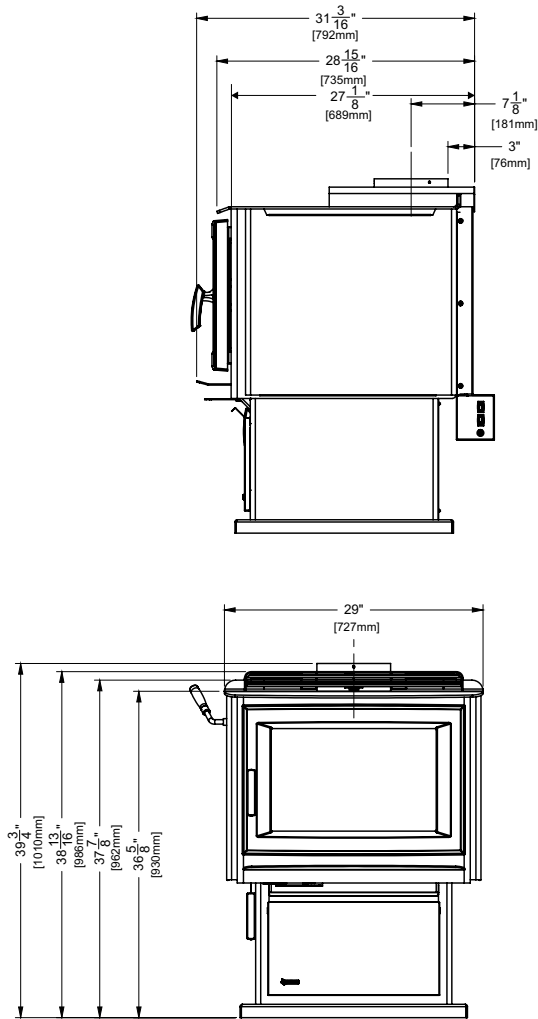

Minimum Clearances to Combustible Materials

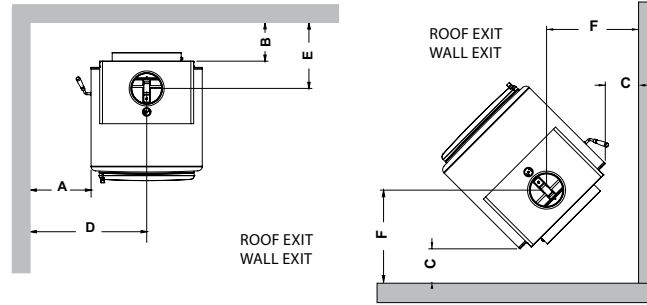

Residential Close Clearance Listed Double Wall Pipe	FROM UNIT		FROM CORNER		FROM FLUE CENTER-LINE		ALCOVE MIN. WIDTH	ALCOVE MAX. DEPTH
	A	B	C	D	E	F	G	H
F5100 with Airmate or Rear Deflector	11"	10"	8"	25-1/2"	17-1/8"	22-1/2"	63"	48"

Mobile Home Close Clearance Listed Double Wall Pipe	FROM UNIT		FROM CORNER		FROM FLUE CENTER-LINE		ALCOVE MIN. WIDTH	ALCOVE MAX. DEPTH
	A	B	C	D	E	F	G	H
F5100 with Airmate or Rear Deflector	11"	10"	8"	25-1/2"	17-1/8"	22-1/2"	63"	48"

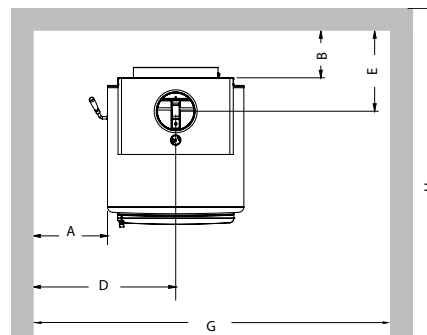

Minimum Alcove Clearance to Combustible Materials

The Regency Freestanding models have been alcove approved and must be installed with a listed double wall connector to the ceiling level.

Note: Minimum alcove ceiling height - 83" Vertical Termination

Floor Protection

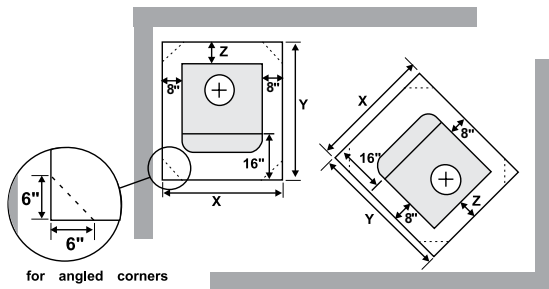

Floor Protection	Residential Close Clearance			Mobile Home Close Clearance		Alcove	
	X	Y	Z	Y	Z	Y	Z
USA	45"	49-1/8"	8"	49-1/8"	8"	49-1/8"	8"
Canada	45"	53-1/8"	8"	53-1/8"	8"	53-1/8"	8"

Your Regency Dealer Is

F5100 Specifications

Max. Cordwood BTUs	80,000	Burn Time (Typical)*	30+ hours
EPA Certified	Yes	Emissions (grams/hr)	1.46 grams
Typical Sq. Ft. Heated	1,500 - 3,000	Firebox Size	4.42 cu. ft.
Efficiency	85.48%	Flue Size	8"
Maximum Log Size	22"		

These are guidelines only, subject to change without notice. Always refer to the actual product manual that comes with your unit for specific, current dimensions and clearances.

© 2013 FPI Fireplace Products International Ltd. Regency is a registered or proprietary trademarks of FPI Fireplace Products International Ltd. All rights reserved. Printed in Canada (02/13)
Part no. 944-415