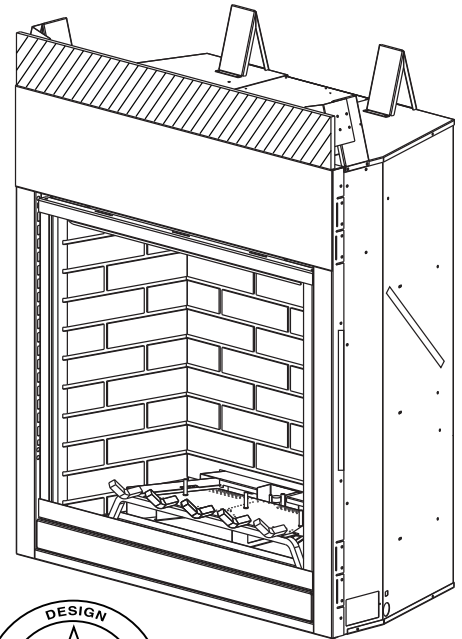




# MLDV Direct Vent Gas Fireplace

**Model: MLDV500**

## Installation & Operating Instructions



### WARNING

IF THE INFORMATION IN THESE INSTRUCTIONS IS NOT FOLLOWED EXACTLY, A FIRE OR EXPLOSION MAY RESULT CAUSING PROPERTY DAMAGE, PERSONAL INJURY OR LOSS OF LIFE.

- Do not store or use gasoline or other flammable vapors and liquids in the vicinity of this or any other appliance.
- **WHAT TO DO IF YOU SMELL GAS**
  - Do not try to light any appliance.
  - Do not touch any electrical switch; do not use any phone in your building.
  - Immediately call your gas supplier from a neighbor's phone. Follow the gas supplier's instructions.
  - If you cannot reach your gas supplier, call the fire department.
- Installation and service must be performed by a qualified installer, service agency or the gas supplier.

**WARNING:** Improper installation, adjustment, alteration, services or maintenance can cause injury or property damage. Refer to this manual. For assistance or additional information consult a qualified installer, service agency or the gas supplier.

This appliance may be installed in an aftermarket\*, permanently located, manufactured home (USA only) or mobile home, where not prohibited by local codes. This appliance is only for use with the type of gas indicated on the rating plate. This appliance is not convertible for use with other gases, unless a certified kit is used.

\* Aftermarket: Completion of sale, not for purpose of resale, from the manufacturer.



**DUE TO HIGH TEMPERATURES, THE APPLIANCE SHOULD BE LOCATED OUT OF TRAFFIC AND AWAY FROM FURNITURE AND DRAPERIES.**

**CHILDREN AND ADULTS SHOULD BE ALERTED TO THE HAZARDS OF HIGH SURFACE TEMPERATURE AND SHOULD STAY AWAY TO AVOID BURNS OR CLOTHING IGNITION.**

**YOUNG CHILDREN SHOULD BE SUPERVISED WHEN THEY ARE IN THE SAME ROOM AS THE APPLIANCE.**

**CLOTHING OR OTHER FLAMMABLE MATERIAL SHOULD NOT BE PLACED ON OR NEAR THE APPLIANCE.**

**KEEP THE ROOM AREA CLEAR AND FREE FROM COMBUSTIBLE MATERIALS, GASOLINE, AND OTHER FLAMMABLE VAPORS AND LIQUIDS.**

**INSTALLER:** Leave this manual with the appliance.

**CONSUMER:** Retain this manual for future reference.

**Thank you and congratulations on your purchase of an  
MHSC Fireplace.**

**PLEASE READ THE INSTALLATION AND OPERATION INSTRUCTIONS BEFORE USING THE APPLIANCE!**

**IMPORTANT: Read all instructions and warnings carefully before starting installation.**

**Failure to follow these instructions may result in a possible fire hazard and will void the warranty.**

<b>Important Safety Information .....</b>	<b>3</b>	<b>Checking Gas Pressure - SCS .....</b>	<b>36</b>
<b>Code Approval .....</b>	<b>4</b>	<b>Electrical Wiring - SCS .....</b>	<b>36</b>
<b>Product Specifications.....</b>	<b>5</b>	Junction Box Wiring .....	37
High Elevations .....	5	Command Center Wall Installation.....	37
Gas Pressures .....	5	Wall Switch Installation .....	37
Gas Specifications & Orifice Size .....	5	Signature Command Wiring Diagram .....	38
<b>Fireplace &amp; Framing Dimensions .....</b>	<b>6</b>	<b>Optional Fan/Blower System - SCS .....</b>	<b>39</b>
<b>Pre-Installation Information.....</b>	<b>7</b>	BLOTSDVSC .....	39
Before You Start.....	7	BLOTSDV .....	40
Items Required for Installation .....	7	<b>Operating Instructions - SCS .....</b>	<b>41</b>
Firebox Framing .....	7	For Your Safety .....	41
Fireplace Location.....	7	Operating Instructions.....	42
<b>Clearances .....</b>	<b>8</b>	To Turn Off Gas To Appliance .....	42
<b>Secure Fireplace to Floor or Framing.....</b>	<b>9</b>	<b>Signature Command System Operation.....</b>	<b>43</b>
Finishing Material.....	9	<b>Final Installation .....</b>	<b>46</b>
<b>Venting Installation.....</b>	<b>10</b>	Glass Frame Removal .....	46
Installation Precautions.....	10	Brick Installation .....	46
Optional Top Vent Application .....	11	Eyebrow/Canopy Installation .....	46
Vent Pipe Clearances .....	12	Rockwool Placement .....	47
Installation Planning.....	13	Log Placement .....	47
Horizontal & Vertical Terminations .....	13	<b>Cleaning and Maintenance .....</b>	<b>50</b>
Termination Location.....	14	Burner, Pilot and Control Compartment.....	50
Termination Clearances .....	15	Pilot Flame .....	50
How to Use the Vent Graph .....	15	Burner Flame .....	50
Rear Wall Vent Installation .....	16	Vent System.....	51
Horizontal w/Vertical Rise Termination Config. ....	17	Glass Door .....	51
Below Grade Installations .....	20	Logs .....	51
Vertical Through-the-Roof Applications.....	21	Rock Wool .....	51
Installation for Vertical Termination .....	22	<b>Troubleshooting .....</b>	<b>52</b>
Flat Ceiling Installation.....	22	Standing Pilot Ignition .....	52
Flex Vent Installation.....	24	Signature Command System .....	54
<b>Fireplace Installation.....</b>	<b>27</b>	<b>Replacement Parts .....</b>	<b>55</b>
Check Gas Type.....	27	Firebox Components.....	55
Gas Line Installation .....	27	Logs .....	56
<b>Check Gas Pressure - Millivolt .....</b>	<b>29</b>	Standing Pilot Millivolt Control .....	57
<b>Electrical Installation - Millivolt.....</b>	<b>29</b>	Signature Command System .....	59
Remote Wall Mounted Switch .....	30	Venting Components.....	61
Optional Fan/Blower - BLOTBLDV) .....	30	<b>Massachusetts Residents Only.....</b>	<b>66</b>
<b>Operating Instructions - Millivolt .....</b>	<b>33</b>	<b>Warranty .....</b>	<b>67</b>
For Your Safety .....	33	<b>Efficiencies.....</b>	<b>68</b>
Lighting Pilot for the First Time .....	33		
Lighting Pilot .....	34		
Lighting Burner.....	35		

**INSTALLER**

Please leave these instructions with the appliance.

**OWNER**

Please retain these instructions for future reference.

<b>WARNING</b>	<ul style="list-style-type: none"> <li>• <b>Read this owner’s manual carefully and completely before trying to assemble, operate, or service this fireplace.</b></li> <li>• <b>Any change to this fireplace or its controls can be dangerous.</b></li> <li>• <b>Improper installation or use of this fireplace can cause serious injury or death from fire, burns, explosions, electrical shock and carbon monoxide poisoning.</b></li> </ul>
----------------	---

This fireplace is a vented product. This fireplace must be properly installed by a qualified service person. The glass door must be properly seated and sealed. If this unit is not properly installed by a qualified service person with glass door properly seated and sealed, combustion leakage can occur.

**CARBON MONOXIDE POISONING:** Early signs of carbon monoxide poisoning are similar to the flu with headaches, dizziness and/or nausea. If you have these signs, the fireplace may not have been installed properly. Get fresh air at once! Have the fireplace inspected and serviced by a qualified service person. Some people are more affected by carbon monoxide than others. These include pregnant women, people with heart or lung disease or anemia, those under the influence of alcohol, and those at high altitudes.

Propane/LP gas and natural gas are both odorless. An odor-making agent is added to each of these gases. The odor helps you detect a gas leak. However, the odor added to these gases can fade. Gas may be present even though no odor exists.

Make certain you read and understand all warnings. Keep this manual for reference. It is your guide to safe and proper operation of this fireplace.

1. This appliance is only for use with the type of gas indicated on the rating plate. This appliance is not convertible for use with other gases unless a certified kit is used.
2. For propane/LP fireplace, do not place propane/LP supply tank(s) inside any structure. Locate propane/LP supply tank(s) outdoors. To prevent performance problems, do not use propane/LP fuel tank of less than 100 lbs. capacity.
3. If you smell gas
  - shut off gas supply.
  - do not try to light any appliance.
  - do not touch any electrical switch; do not use any phone in your building .
  - immediately call your gas supplier from a neighbor’s phone. Follow the gas supplier’s instructions.

4. Never install the fireplace
  - in a recreational vehicle
  - where curtains, furniture, clothing, or other flammable objects are less than 42" from the front, top, or sides of the fireplace
  - in high traffic areas
  - in windy or drafty areas
5. This fireplace reaches high temperatures. Keep children and adults away from hot surfaces to avoid burns or clothing ignition. Fireplace will remain hot for a time after shutdown. Allow surfaces to cool before touching.
6. Young children should be carefully supervised when they are in the same room as the appliance. Toddlers, young children and others may be susceptible to accidental contact burns. A physical barrier is recommended if there are at risk individuals in the house. To restrict access to a fireplace or stove, install an adjustable safety gate to keep toddlers, young children and other at risk individuals out of the room and away from hot surfaces.
7. Do not modify fireplace under any circumstances. Any parts removed for servicing must be replaced prior to operating fireplace.
8. Turn fireplace off and let cool before servicing, installing, or repairing. Only a qualified service person should install, service, or repair the fireplace. Have burner system inspected annually by a qualified service person.
9. You must keep control compartments, burners, and circulating air passages clean. More frequent cleaning may be needed due to excessive lint and dust. Turn off the gas valve and pilot light before cleaning fireplace.
10. Have venting system inspected annually by a qualified service person. If needed, have venting system cleaned or repaired. See *Cleaning and Maintenance*, Page 50.
11. Keep the area around your fireplace clear of combustible materials, gasoline, and other flammable vapor and liquids. Do not run fireplace where these are used or stored. Do not place items such as clothing or decorations on or around fireplace.

12. Do not use this fireplace to cook food or burn paper or other objects.
13. Never place anything on top of fireplace.
14. Do not use any solid fuels (wood, coal, paper, cardboard, etc.) in this fireplace. Use only the gas type indicated on rating plate.
15. This appliance, when installed, must be electrically grounded in accordance with local codes or in the absence of local codes, with the *National Electrical Code*, *ANSI/NFPA 70*, or the *Canadian Electrical Code*, *CSA C22.1*.
16. Do not obstruct the flow of combustion and ventilation air in any way. Provide adequate clearances around air openings into the combustion chamber along with adequate accessibility clearance for servicing and proper operation.
17. When the appliance is installed directly on carpeting, tile or other combustible material other than wood flooring, you must set appliance on a metal or wood panel or hearth pad extending the full width and depth of the appliance.
18. Do not use fireplace if any part has been exposed to or has been under water. Immediately call a qualified service technician to inspect the appliance and replace any part of the control system and any gas control which as been submerged in water.
19. Do not operate fireplace if any log is broken.
20. Do not use a blower insert, heat exchanger insert, or any other accessory not approved for use with this fireplace.
21. Do not operate the fireplace with glass door removed, cracked, or broken.

**CODE APPROVAL**

Direct Vent type appliances draw all combustion air from outside of the dwelling through the vent pipe.

These appliances have been tested by CSA and found to comply with the established standards for DIRECT VENT GAS FIREPLACE HEATERS in the USA and Canada as follows:

**LISTED VENTED GAS FIREPLACE HEATER**

TESTED TO:

ANSI Z21.88-2009 / CSA 2.33-2009 STANDARDS

A manufactured home (USA only) or mobile home OEM installation must conform with the **Manufactured Home Construction and Safety Standard, Title 24 CFR, Part 3280**, or when such a standard is not applicable, the **Standard for Manufactured Home Installations, ANSI/NCSBCS A225.1**, or **Standard for Gas Equipped Recreational Vehicles and Mobile Housing, CSA Z240.4**.

**IMPORTANT:  
PLEASE READ THE FOLLOWING  
CAREFULLY**

It is normal for fireplaces fabricated of steel to give off some expansion and/or contraction noises during the start up or cool down cycle. Similar noises are found with your furnace heat exchanger or car engine.

**IMPORTANT:  
PLEASE READ THE FOLLOWING  
CAREFULLY**

It is not unusual for gas fireplaces to give off some odor the first time it is burned. This is due to the manufacturing process.

**Please ensure that your room is well ventilated during burn off — open all windows.**

It is recommended that you burn your fireplace for at least ten (10) hours the first time you use it. Place the fan switch in the "OFF" position during this time.

**WARNING**

**Never connect unit to private (non-utility) gas wells. This gas is commonly known as wellhead gas.**

NATIONAL  
FIREPLACE  
INSTITUTE



CERTIFIED  
www.nficertified.org

We recommend that our gas hearth products be installed and serviced by professionals who are certified in the U.S. by the National Fireplace Institute® (NFI) as NFI Gas Specialists.

**! WARNING**



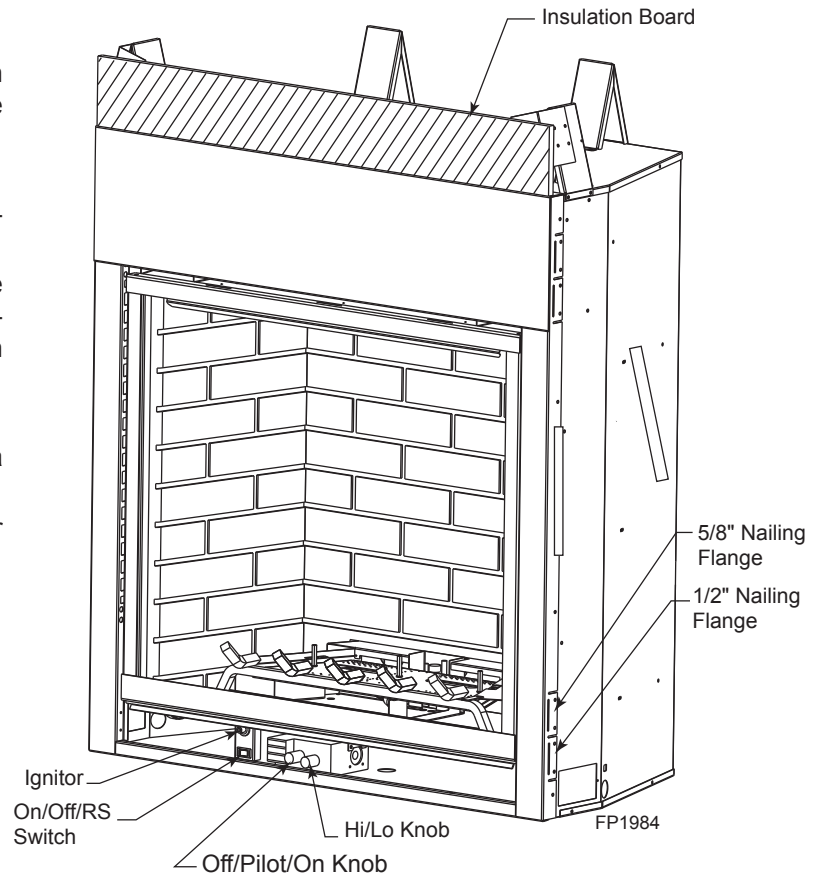
**HOT GLASS WILL  
CAUSE BURNS.  
DO NOT TOUCH GLASS  
UNTIL COOLED.  
NEVER ALLOW CHILDREN  
TO TOUCH GLASS.**

## PRODUCT FEATURES

## MLDV Series Gas Fireplace

### PRODUCT SPECIFICATIONS

- This appliance has been certified for use with either natural or propane gas. See appropriate data plates.
- This appliance is not for use with solid fuels.
- The appliance is approved for bedroom or bed-sitting room installations.
- The appliance must be installed in accordance with local codes if any. If none exist use the current installation code. ANSI Z223.1/NFPA 54 in the USA, CSA B149 in Canada.
- This appliance is mobile home approved.
- The appliance must be properly connected to a venting system.
- The appliance is not approved for closet or recessed installations.



**Figure 1 -**  
**MLDV Series Fireplace**  
**(Millivolt Control shown)**

### HIGH ELEVATIONS

Input ratings are shown in BTU per hour and are certified without deration for elevations up to 4,500 feet (1,370 m) above sea level.

For elevations above 4,500 feet (1,370 m) in USA, installation must be in accordance with the current ANSI Z223.1/NFPA 54 and/or local codes having jurisdiction.

In Canada, please consult provincial and/or local authorities having jurisdiction for installation at elevations above 4,500 feet (1,370 m).

### GAS SPECIFICATIONS & ORIFICE SIZE

Model	Fuel	Max. Input BTU/h	Min. Input BTU/h	Orifice Size
MLDV500NV	Nat.	34,000	22,000	#33
MLDV500PV	LP	34,000	27,000	1.8 mm
MLDV500NSC	Nat.	34,000	22,000	#33
MLDV500PSC	LP	34,000	27,000	1.8 mm

### GAS PRESSURES

	Natural	Propane (LP)
Inlet Minimum	4.5" w.c.	11.0" w.c.
Inlet Maximum	10.5" w.c.	13.0" w.c.
Manifold Pressure	3.5" w.c.	10.0" w.c.

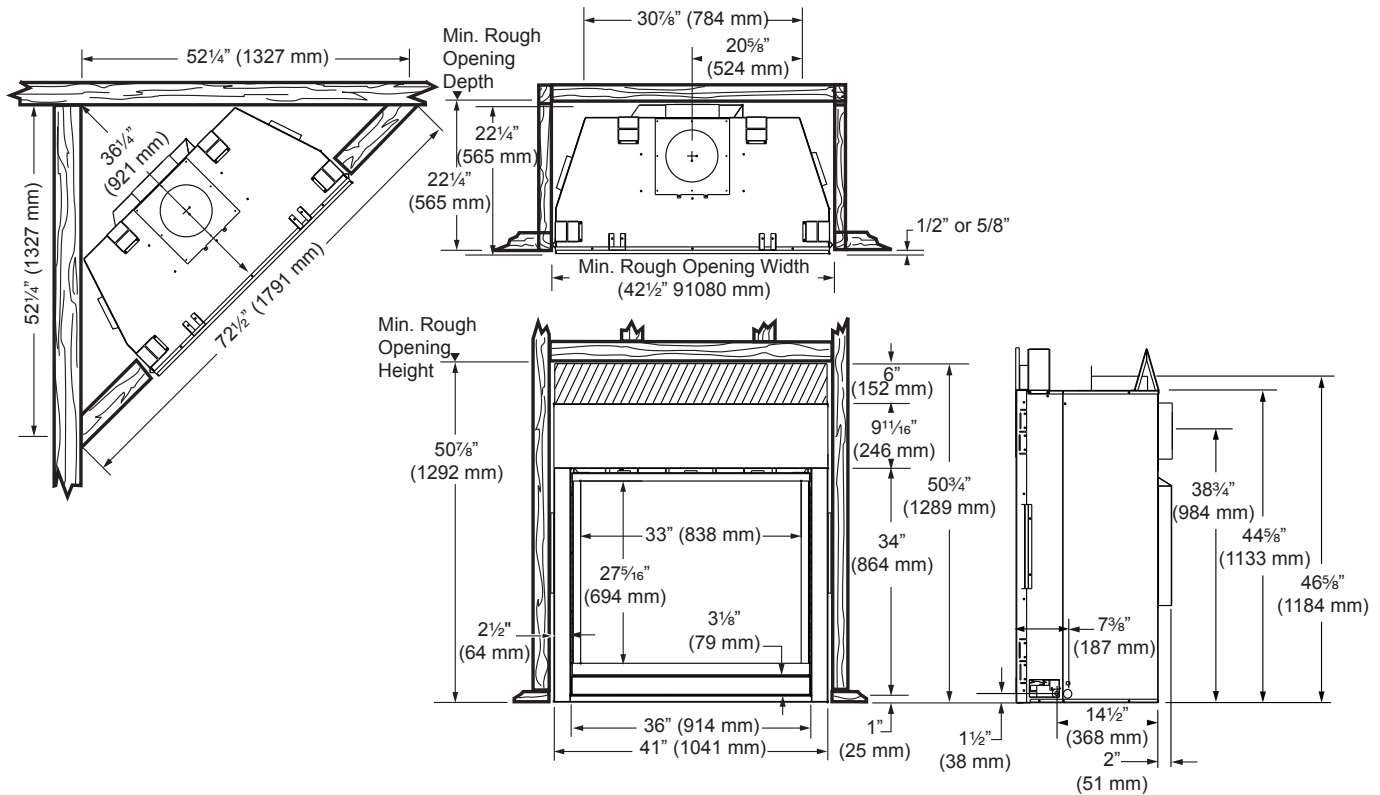


Figure 2 -  
Fireplace and Framing Dimensions

**WARNING**

Do not fill spaces around firebox with insulation or other materials. This could cause a fire.

**NOTE**

**COLD CLIMATE INSULATION**

If you live in a cold climate, seal all cracks around your appliance, and wherever cold air could enter the room, with noncombustible material. It is especially important to insulate the outside chase cavity between the studs and under the floor on which the appliance rests, if the floor is above ground level.

**BEFORE YOU START**

Read this homeowner manual thoroughly and follow all instructions carefully. Inspect all contents for shipping damage and immediately inform your dealer if any damage is found. Do not install any unit with damaged, incomplete, or substitute parts. Check your packing list to verify that all listed parts have been received. You should have the following:

- Fireplace (Firebox and Burner System)
- Log Set
- Rock Wool

**ITEMS REQUIRED FOR INSTALLATION**

**Tools and Building Materials**

- Phillips Screwdriver
- Hammer
- Saw and/or saber saw
- Measuring Tape
- Electric Drill and Bits
- Pipe Wrench
- Caulking Material (noncombustible)
- Fireplace Surround Material (noncombustible)
- Piping Complying with Local Codes
- Pipe Sealant Approved for use with Propane/LPG (Resistant to sulfur compounds)
- Framing Materials
- Wall Finishing Materials
- Level
- Pliers
- Square
- Tee Joint

**FIREBOX FRAMING**

Firebox framing can be built before or after the appliance is set in place. Construct firebox framing following *Figure 2* for firebox and framing dimensions. The framing headers may rest on the top of the firebox standoffs. Do not bring headers below top of standoffs. **NOTE:** When planning your framing and installation, keep in mind that your gas line will come in on the right side of the box (as you are facing it) and your electricity will come in on the left side.

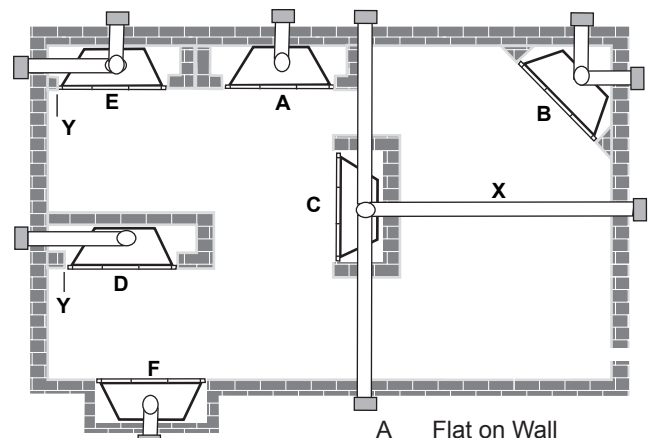
The firebox may be installed directly on a combustible floor or raised on a platform of an appropriate height. When the firebox is installed directly on carpeting, tile, or other combustible material, other than wood flooring, the firebox shall be installed on a metal or wood panel extending the full width and depth of the enclosure.

**FIREPLACE LOCATION**

Plan for the installation of your appliance. This includes determining where the unit is to be installed, the vent configuration to be used, framing and finishing details, and whether any optional accessories (i.e. blower, wall switch, or remote control) are desired. Consult your local building code agency to ensure compliance with local codes, including permits and inspections.

The following factors should be taken into consideration:

- Clearance to side-wall, ceiling, woodwork, and windows. Minimum clearances to combustibles **must be maintained.**
- This fireplace may be installed along a wall, across a corner, or use an exterior chase. Refer to *Figure 3* for suggested locations.
- Location should be out of high traffic areas and away from furniture and draperies due to heat from appliance.
- Never obstruct the front opening of the fireplace.
- Do **not** install in the vicinity where gasoline or other flammable liquids may be stored.
- Vent pipe routing. See *Venting* section found in this manual for allowable venting configurations.
- These units can be installed in a bedroom. See National Fuel Gas Code ANSI Z233.1/NFPA 54 — (current edition), the Uniform Mechanical Code — (current edition), and Local Building Codes for specific installation requirements.
- These units can be installed in a bathroom.



**Figure 3 -  
Locate Gas Fireplace**

- A Flat on Wall
- B Cross Corner
- C Island\*\*
- D Room Divider\*
- E Flat on Wall Corner\*
- F Chase Installation
- Y 6" Minimum

\*\* Island (C) and room divider (D) installation is possible as long as the horizontal portion of vent system (X) does not exceed 20'. See *Install Horizontal Termination Configuration* on Pages 18 and 19.

\* When you install your fireplace in (D) room divider or (E) flat on wall corner positions (Y), a minimum of 6" clearance must be maintained from perpendicular wall and front of fireplace.

CLEARANCES TO COMBUSTIBLES

**WARNING**

Follow these instructions carefully to ensure safe installation. Failure to follow instructions exactly can create a fire hazard.

The appliance cannot be installed on a carpet, tile or other combustible material other than wood flooring. If installed on carpet or vinyl flooring, the appliance shall be installed on a metal, wood or noncombustible material panel extending full width and depth of the appliance.

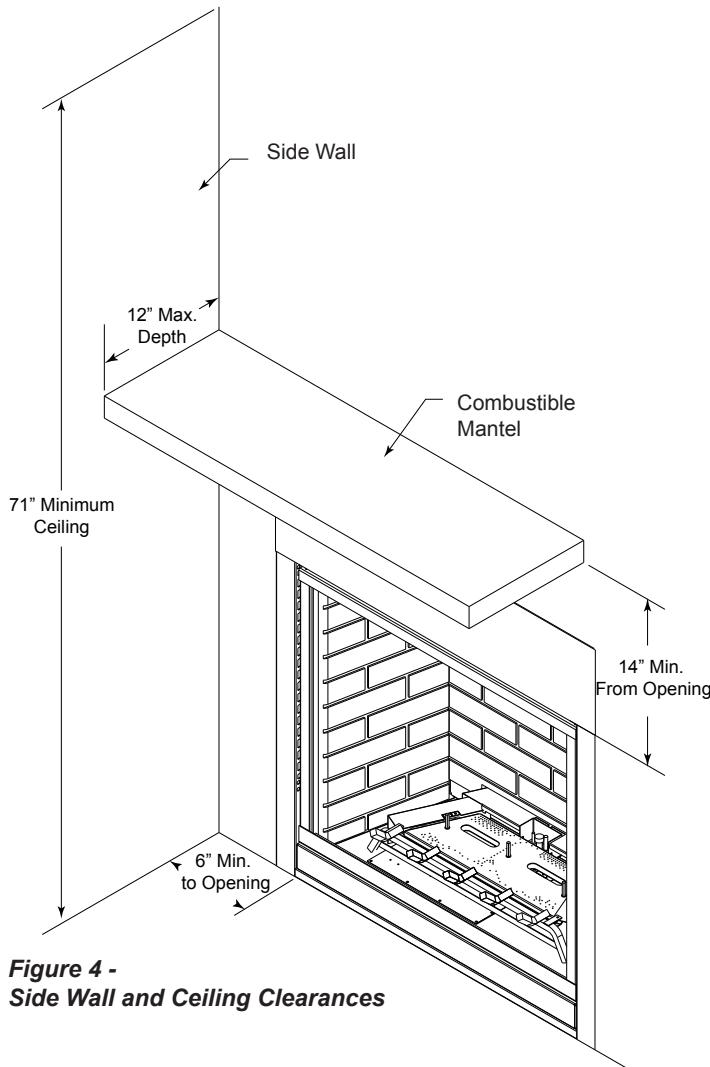


Figure 4 - Side Wall and Ceiling Clearances

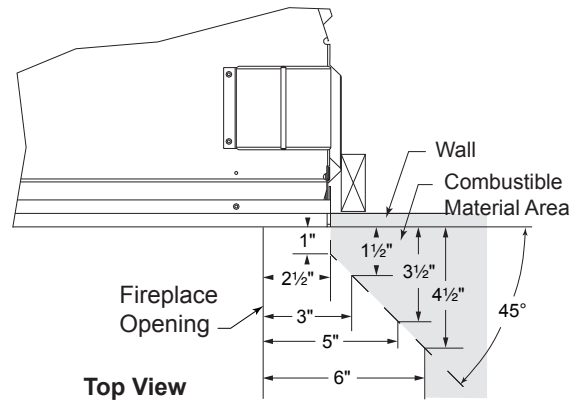


Figure 5 - Mantel clearances.

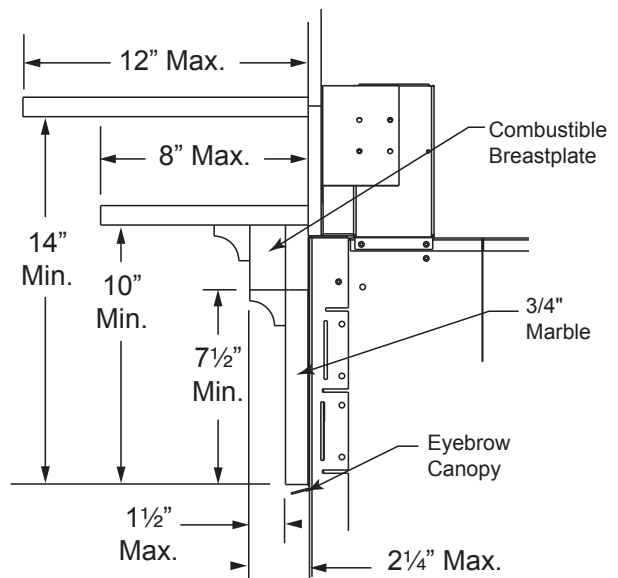


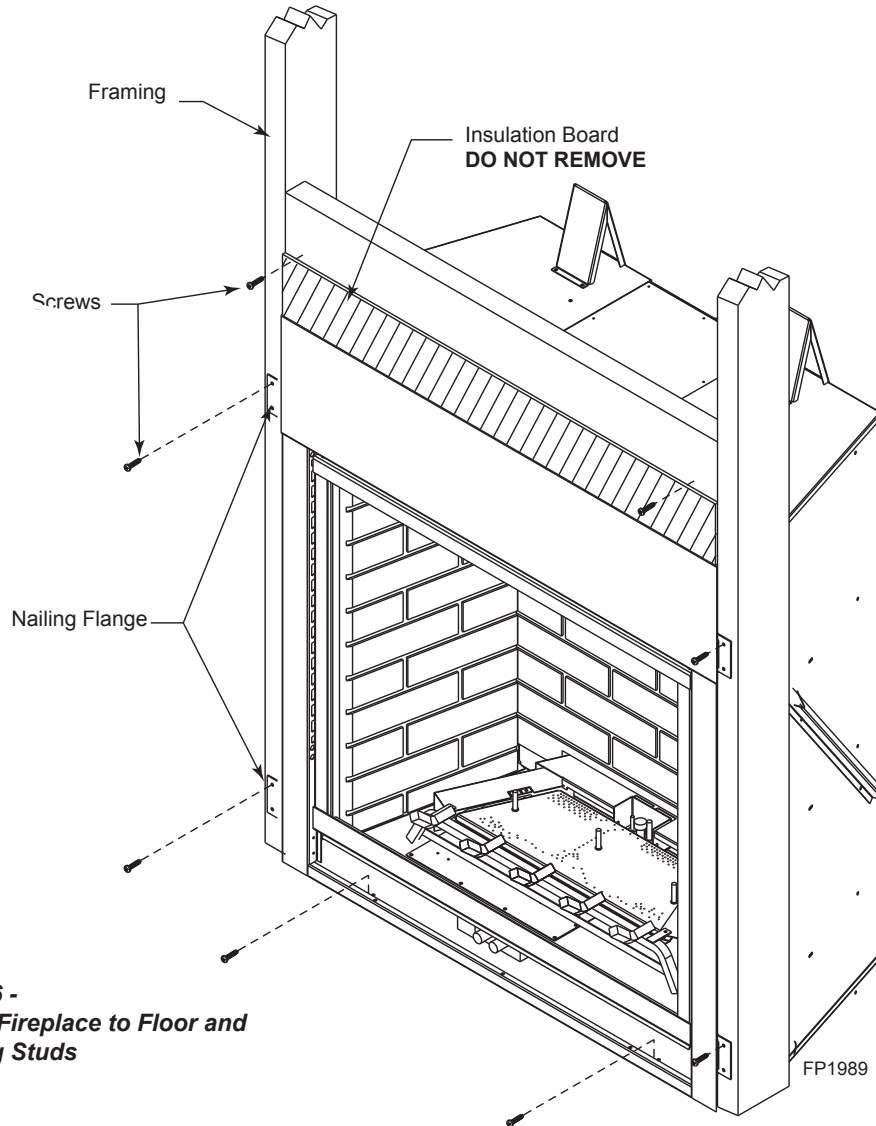
Figure 5a - Mantel Clearance with Eyebrow Canopy

**NOTE:** When eyebrow canopy is used, minimum clearance to combustibles is 2 1/4" maximum out from fireplace front at 7 1/2" minimum from opening. Figure 5a. When eyebrow is not used, clearances to combustibles is 8" maximum out from fireplace front at 10" minimum from opening or 12" maximum out from fireplace front at 14" minimum from opening. Figure 5



The fireplace must be secured to the floor and/or to framing studs as shown in *Figure 6*. Use two (2) wood screws or masonry/ concrete screws to secure fireplace to the floor. Use four (4) screws to attach fireplace to framing. The side nailing flanges are 1/2" or 5/8" to accommodate different wall thickness.

**NOTE**  
**DO NOT REMOVE INSULATION BOARD**



**Figure 6 -  
Secure Fireplace to Floor and  
Framing Studs**

**FINISHING MATERIAL**

**NOTE:** Any remote wiring (i.e. remote control, wall switch, and optional fan) must be done prior to final finishing to avoid costly reconstruction.

Only noncombustible materials (i.e. brick, tile, slate, steel, or other materials with a UL fire rating of Zero) may be used to cover the black painted face of the appliance. It is permissible to bring combustible wall board to the top and side edges of the black painted face. A 300°F minimum adhesive may be used to attach facing materials to the black surface. If joints between the finished wall and the fireplace surround are sealed, a 300°F minimum sealant material (General Electric RTV103 or equivalent) must be used.

## VENTING INSTALLATION

**WARNING**

**Read all instructions completely and thoroughly before attempting installation. Failure to do so could result in serious injury, property damage or loss of life. Operation of improperly installed and maintained venting system could result in serious injury, property damage or loss of life.**

**NOTICE**

**Failure to follow these instructions will void the warranty.**

**INSTALLATION PRECAUTIONS**

Consult local building codes before beginning the installation. The installer must make sure to select the proper vent system for installation. Before installing vent kit, the installer must read this fireplace manual and vent kit instructions.

Only a qualified installer/service person should install venting system. The installer must follow these safety rules:

- Wear gloves and safety glasses for protection.
- Use extreme caution when using ladders or when on rooftops.
- Be aware of electrical wiring locations in walls and ceilings.

The following actions will void the warranty on your venting system:

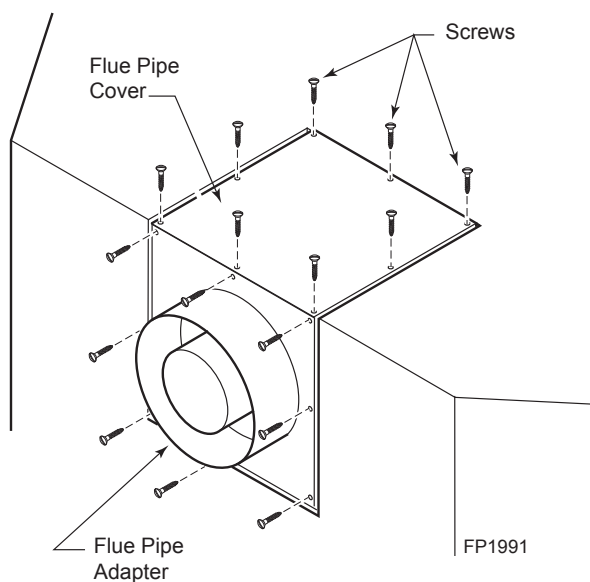
- Installation of any damaged venting component.
- Unauthorized modification of the venting system.
- Installation of any component part not manufactured or approved by MHSC.
- Installation other than permitted by these instructions.

**OPTIONAL TOP VENT APPLICATION**

The appliance is shipped as a rear vent unit. If the installation layout requires the unit to be a top vent configuration, the appliance can be converted by following the steps below.

When removing and refitting the plates and adapter, be sure the associated gaskets are undamaged and refitted as required.

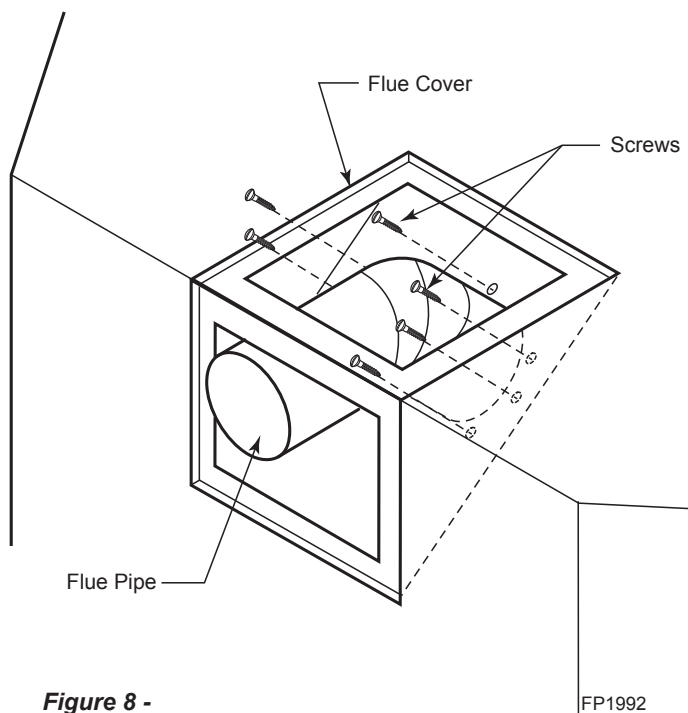
1. Remove the eight (8) screws securing the flue pipe adapter to the fireplace body. *Figure 7*
2. Set the flue pipe adapter aside, complete with the gasket. Do not damage the gaskets as the adapter and gasket must be refitted.



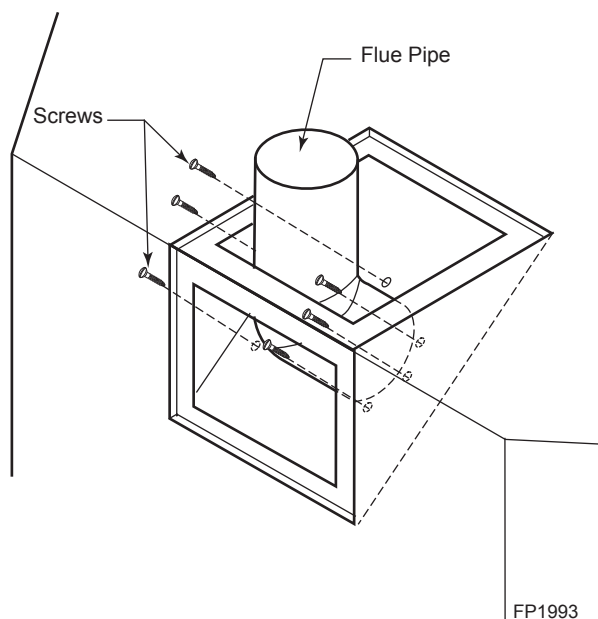
**Figure 7 - Remove 16 screws from Flue Pipe Adapter and Flue Pipe Cover**

3. Remove the eight (8) screws securing the flue pipe cover to the top of the intake box and remove the cover and gasket. *Figure 7*
4. Remove six (6) screws securing the flue pipe to the back of the intake box and remove the pipe and gasket. *Figure 8*
5. Replace the flue pipe to top of firebox. Ensure the gasket is in place and undamaged. Secure with six (6) screws. *Figure 9*
6. Place the flue pipe cover and gasket removed in Step 3 over the flue opening in bottom of the intake box.
7. Refit the flue pipe adapter and gasket to the top of fireplace. Secure the adapter with six (6) screws removed in Step 1.

**WARNING** After conversion to top vent configuration, the 5" (127 mm) flue pipe should be concentric with the 8" (203 mm) outer collar within 1/4".



**Figure 8 - Remove Flue Pipe**



**Figure 9 - Attach Flue Pipe to Top Vent Configuration**

**WARNING**

Horizontal sections of this vent system require a minimum of 3" clearances to combustibles at the top of the flue and 1" clearance at the sides and bottom until the flue penetrates the outside wall. A minimum 1" clearance all around the flue is acceptable at this point of penetration. If vertical rise is 7½" feet or higher when top venting, the clearance to combustibles is 1" on all sides of the horizontal run.

Vertical sections of this vent system require a minimum of 1" clearance to combustibles on all sides of the pipe.

**WARNING**

This fireplace must be vented to the outside. The venting system must NEVER be attached to a chimney serving a separate solid fuel burning appliance. Each gas appliance must use a separate vent system. Do not use common vent systems.

\* A minimum of 3" clearance to the top is required along horizontal length until flue pipe penetrates outside wall.

\*\* A minimum 1" clearance to combustibles permitted all around flue at outside wall

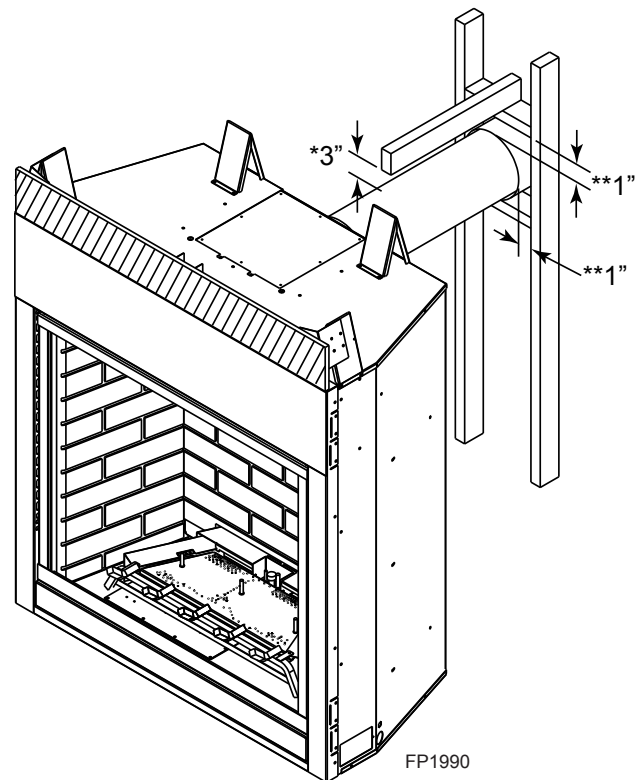
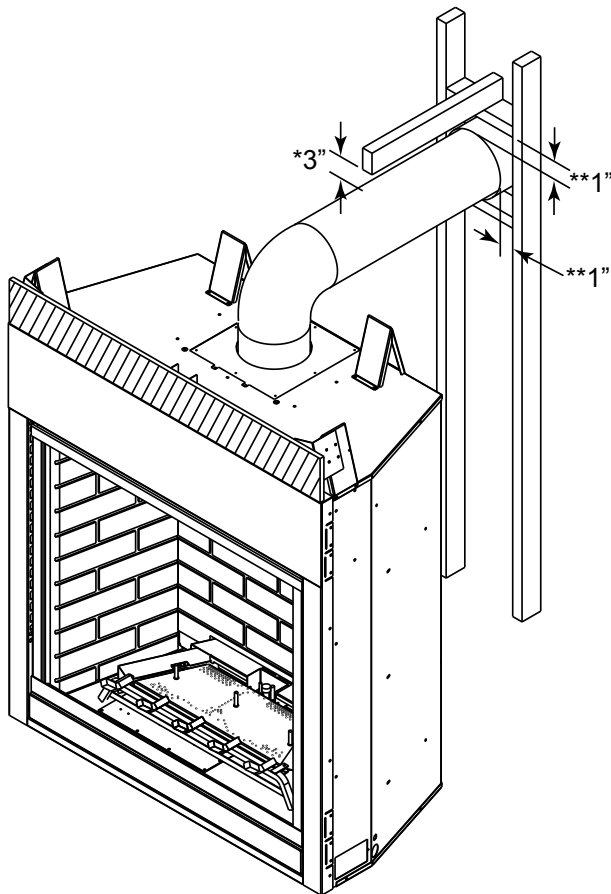


Figure 10 -  
Combustible Clearances for Vent Pipe

**WARNING** Read all instructions completely and thoroughly before attempting installation. Failure to do so could result in serious injury, property damage or loss of life. Operation of improperly installed and maintained venting system could result in serious injury, property damage or loss of life.

**INSTALLATION PLANNING**

There are two basic types of direct-vent installation:

- Horizontal Termination
- Vertical Termination

It is important to select the proper length of vent pipe for the type of termination you choose. It is also important to note the wall thickness.

**FOR HORIZONTAL TERMINATION**

Select the amount of vertical rise desired. All horizontal run of venting must have 1/4" rise for every 12" of run towards the termination below 7 1/2 feet of vertical rise. With 7 1/2 feet or more vertical rise off top of fireplace, the horizontal run may run level. NEVER run vent piping downward.

You may use up to three 90° elbows in this vent configuration. Refer to Horizontal Termination Configurations on Pages 17 and 18.

**FOR VERTICAL TERMINATION**

Measure the distance from the fireplace floor to the ceiling. Add the ceiling thickness, the vertical rise in an attic or second story, and allow for sufficient vent height above the roof line.

**NOTE:** You may use two 45° elbows in place of a 90° elbow. You must follow rise to run ratios when using 45° elbows. The appliance is approved for use with three 90° elbows maximum or a combination of 90° and 45° elbows up to a maximum of 270°.

**WARNING** Never run the vent pipe down. This may cause excessive temperatures which could cause a fire.

**WARNING** Treatment of firestops and construction of the chase may vary from building type to building type. These instructions are not substitutes for the requirements of local building codes. You must follow all local building codes.

For two-story applications, firestops are required at each floor level. If an offset is needed in the attic, additional pipe and elbows will be required.

You may use a chase with a vent termination with exposed pipe on the exterior of the house. Refer to *Installing Vent System in a Chase* below. If pipe is enclosed in chase, it is not exposed.

It is very important that the venting system maintain its balance between the combustion air intake and the flue gas exhaust. Certain limitations apply to vent configurations and must be strictly followed.

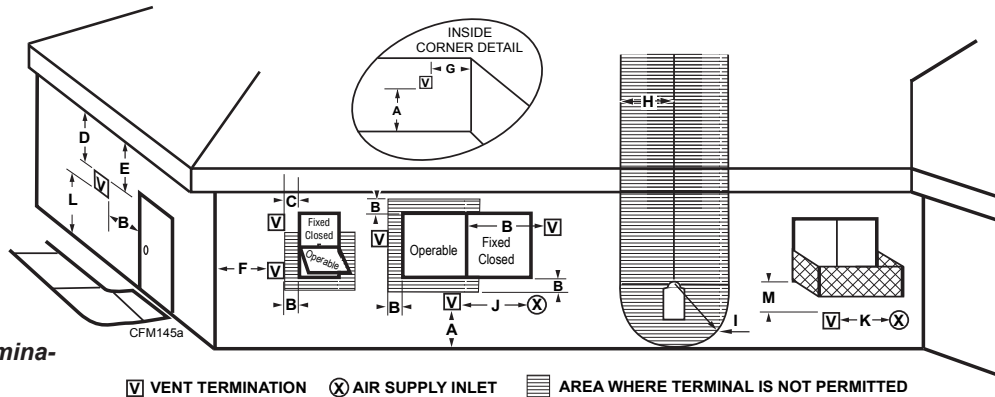
**INSTALLING A VENT SYSTEM IN AN OUTSIDE CHASE**

A chase is a vertical boxlike structure built to enclose venting that runs along the outside of a building. A chase is required for such venting.

**NOTICE** When installing in a chase, you should insulate the chase as you would the outside walls of your home. This is especially important in cold climates. Insulation should be considered a combustible material. Maintain proper clearances to all combustible materials.

**WARNING** Always maintain minimum clearances around vent systems. The minimum clearance to combustibles for horizontal vent pipe are 3" at the top and 1" at the sides and bottom of the vent system until the pipe penetrates the nearest vertical wall (1" required). A 1" minimum clearance all around the pipe must be maintained at outside wall and on vertical runs. Do not pack the open air spaces with insulation or other materials. This could cause high temperatures and may present a fire hazard.  
  
\*Unless the vertical run is 7 1/2 feet or higher (top vent units only), the clearances for the horizontal run is 1" at the top.

**GENERAL VENTING INFORMATION - TERMINATION LOCATION**



**Figure 11 - Horizontal Vent Termination Locations**

☐ V VENT TERMINATION    ⊗ AIR SUPPLY INLET    ▨ AREA WHERE TERMINAL IS NOT PERMITTED

	Canadian Installations <sup>1</sup>	US Installations <sup>2</sup>
A = Clearance above grade, veranda, porch, deck, or balcony	12" (30 cm)	12" (30 cm)
B = Clearance to window or door that may be opened	6" (15 cm) for appliances < 10,000BTU/h (3kW), 12" (30 cm) for appliances > 10,000 Btuh (3kW) and < 100,000 BTU/h (30kW), 36" (91 cm) for appliances > 100,000 BTU/h (30kW)	6" (15 cm) for appliances < 10,000 BTU/h (3kW), 9" (23 cm) for appliances > 10,000 Btuh (3kW) and < 50,000 BTU/h (15kW), 12" (30 cm) for appliances > 50,000 BTU/h(15kW)
C = Clearance to permanently closed window	12" (305 mm) recommended to prevent window condensation	12" (305 mm) recommended to prevent window condensation
D = Vertical clearance to ventilated soffit located above the terminal within a horizontal distance of 2' (610mm) from the center line of the terminal	18" (458 mm)	18" (458 mm)
E = Clearance to unventilated soffit	12" (305 mm)	12" (305 mm)
F = Clearance to outside corner	see next page	see next page
G = Clearance to inside corner (see next page)	see next page	see next page
H = Clearance to each inside of center line extended above meter/regulator assembly	3' (91 cm) within a height of 15' (5 m) above the meter/regulator assembly	3' (91 cm) within a height of 15' (5 m) above the meter/regulator assy
I = Clearance to service regulator vent outlet	3' (91 cm)	3' (91 cm)
J = Clearance to nonmechanical air supply inlet to building or the combustion air inlet to any other appliances	6" (15 cm) for appliances < 10,000 BTU/h (3kW), 12" (30 cm) for appliances > 10,000 BTU/h (3kW) and < 100,000 Btuh (30kW), 36" (91 cm) for appliances > 100,000 BTU/h (30kW)	6" (15 cm) for appliances < 10,000 BTU/h (3kW), 9" (23 cm) for appliances > 10,000 BTU/h (3kW) and < 50,000 BTU/h (15kW), 12" (30 cm) for appliances > 50,000 BTU/h(15kW)
K = Clearance to a mechanical air supply inlet	6' (1.83 m)	3' (91 cm) above if within 10' (3 m) horizontally
L = Clearance above paved sidewalk or paved driveway located on public property	7' (2.13 m)†	7' (2.13 m)†
M = Clearance under veranda, porch, deck or balcony	12" (30 cm)‡	12" (30cm)‡

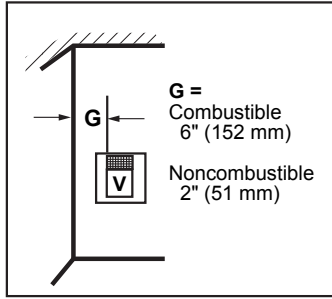
1 In accordance with the current CSA-B149 Installation Codes  
 2 In accordance with the current ANSI Z223.1/NFPA 54 National Fuel Gas Codes  
 † A vent shall not terminate directly above a sidewalk or paved driveway which is located between two single family dwellings and serves both dwellings  
 ‡ only permitted if veranda, porch, deck or balcony is fully open on a minimum 2 sides beneath the floor:

NOTE: 1. Local codes or regulations may require different clearances.  
 2. The special venting system used on Direct Vent Fireplaces are certified as part of the appliance, with clearances tested and approved by the listing agency.  
 3. MHSC assumes no responsibility for the improper performance of the appliance when the venting system does not meet these requirements.

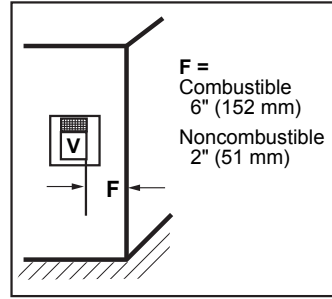
**Termination Clearances**

Termination clearances for buildings with combustible and noncombustible exteriors.

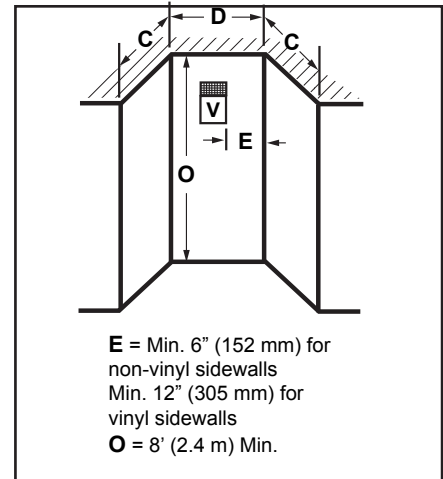
**Inside Corner**



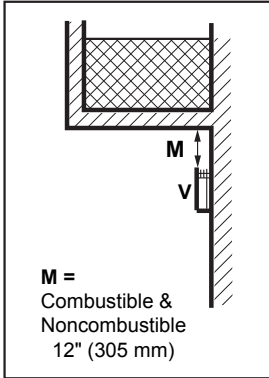
**Outside Corner**



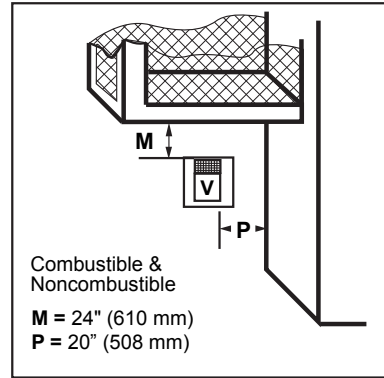
**Alcove Applications\***



**Balcony - with no side wall**



**Balcony - with perpendicular side wall**



584-15

No. of Caps	D <sub>Min.</sub>	C <sub>Max.</sub>
1	3' (914 mm)	2 x D <sub>Actual</sub>
2	6' (1.8 m)	1 x D <sub>Actual</sub>
3	9' (2.7 m)	2/3 x D <sub>Actual</sub>
4	12' (3.7 m)	1/2 x D <sub>Actual</sub>

D<sub>Min.</sub> = # of Termination caps x 3  
C<sub>Max.</sub> = (2 / # termination caps) x D<sub>Actual</sub>

Figure 12 - Allowable Venting

**\*NOTE:** Termination in an alcove space (spaces open only on one side and with an overhang) is permitted with the dimensions specified for vinyl or non-vinyl siding and soffits. 1. There must be a 3' (914 mm) minimum between termination caps. 2. All mechanical air intakes within 10' (1 m) of a termination cap must be a minimum of 3' (914 mm) below the termination cap. 3. All gravity air intakes within 3' (914 mm) of a termination cap must be a minimum of 1' (305 mm) below the termination cap.

**HOW TO USE THE VENT GRAPH**

The Vent Graph should be read in conjunction with the following vent installation instructions to determine the relationship between the vertical and horizontal dimensions of the vent system.

1. Determine the height of the center of the horizontal vent pipe exiting through the outer wall. Using this dimension on the Sidewall Vent Graph below, locate the point intersecting with the slanted graph line.
2. From the point of this intersection, draw a vertical line to the bottom of the graph.
3. Select the indicated dimension, and position the fireplace in accordance with same.

**Example:** If the vertical dimension from the floor of the fireplace is 11' (3.4 m) the horizontal run to the face of the outer wall must not exceed 14' (4.3 m).

**Example:** If the vertical dimension from the floor of the unit is 7' (2.14 m), the horizontal run to the face of the outer wall must not exceed 7' (2.1 m).

Sidewall Vent Graph showing the relationship between vertical and horizontal dimensions for a Direct Vent flue system.

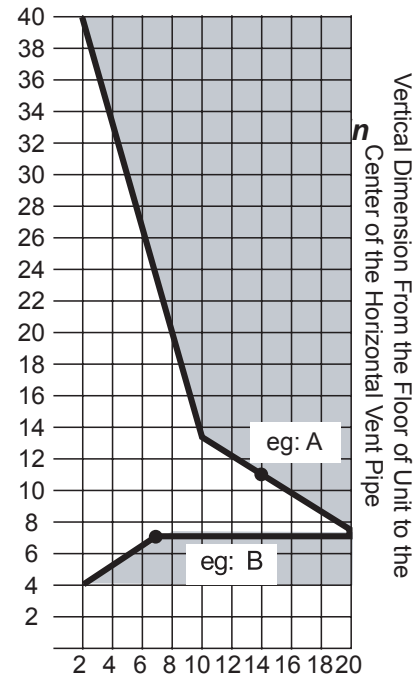
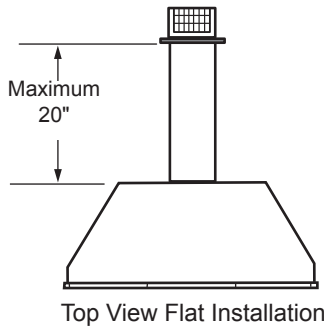


Figure 13 - Rear Wall Venting Graph

## REAR WALL VENT INSTALLATION (5" x 8" VENTING ONLY)

When installed as a rear vent unit, this appliance may be vented directly to a termination located on the rear wall behind the appliance. Only an MHSC brand termination is allowed for this application.

- The maximum horizontal distance between the rear of the appliance and the termination is 20" (508 mm). *Figure 14*

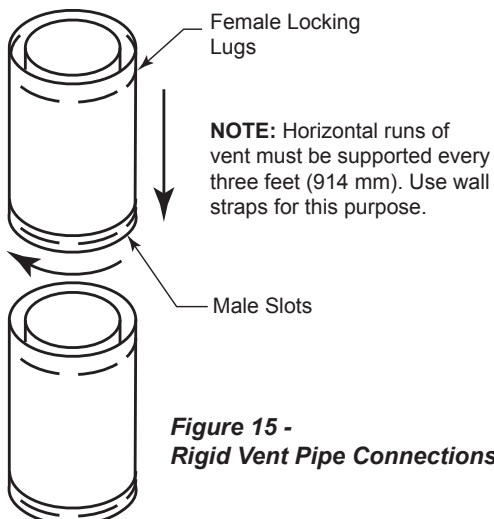


**Figure 14 - Rear Vent Application, Maximum Horizontal Distance**

- Only one 45 degree elbow is allowed in these installations.
- Rigid vent pipes and fittings have special twist-lock connections. Assemble the desired combination of pipe and elbows to the appliance adapter.

**Twist-Lock Procedure:** The female ends of the pipes and fittings have three (3) locking lugs (indentations). These lugs will slide straight into matching slots on the male end of adjacent pipes and fittings. Push the pipe sections together and twist one section clockwise approximately one-quarter turn until the sections are fully locked. *Figure 15*

**NOTE: Sealant is not required to assemble fireplace venting. Do not use silicone sealant at the inner flue exhaust connections.**



**Figure 15 - Rigid Vent Pipe Connections**

- Refer to venting and termination instructions for further instructions.

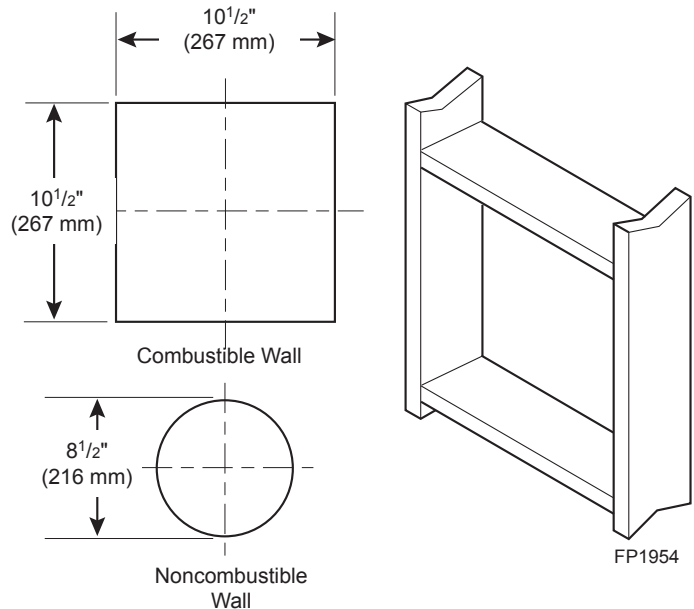
- Locate and cut the vent opening in the wall. For combustible walls first frame in opening.

**Combustible Interior Walls:** Cut a 12<sup>1</sup>/<sub>2</sub>" x 10<sup>1</sup>/<sub>2</sub>" hole through the interior wall.

**Combustible Exterior Walls:** Cut a 10<sup>1</sup>/<sub>2</sub>" x 10<sup>1</sup>/<sub>2</sub>" square hole through the exterior wall frame. *Figure 16*

**Noncombustible Walls:** Hole opening should be 8<sup>1</sup>/<sub>2</sub>" (216 mm) in diameter.

- The center of the hole should align with the center line of the horizontal rigid vent pipe end. Allow 1/4" minimum rise per foot. *Figure 16*



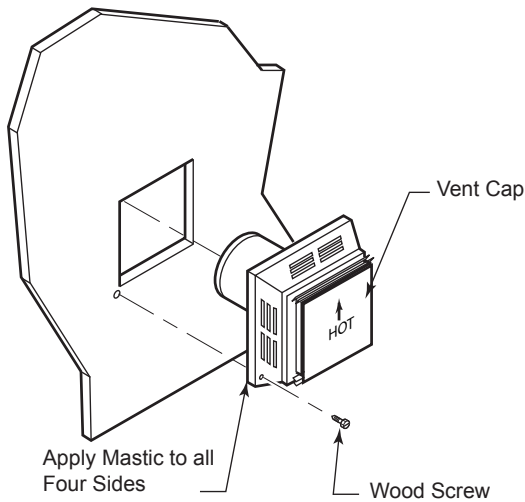
**Figure 16 - Exterior Wall Framing Dimensions**

- Apply a bead of non-hardening mastic around the outside edge of vent cap. Position the vent cap in the center of hole on the exterior wall with the word "UP" on the vent cap facing up. Insure proper clearance of 1" to combustibles is maintained. Attach the vent cap with four (4) wood screws supplied. *Figure 17*

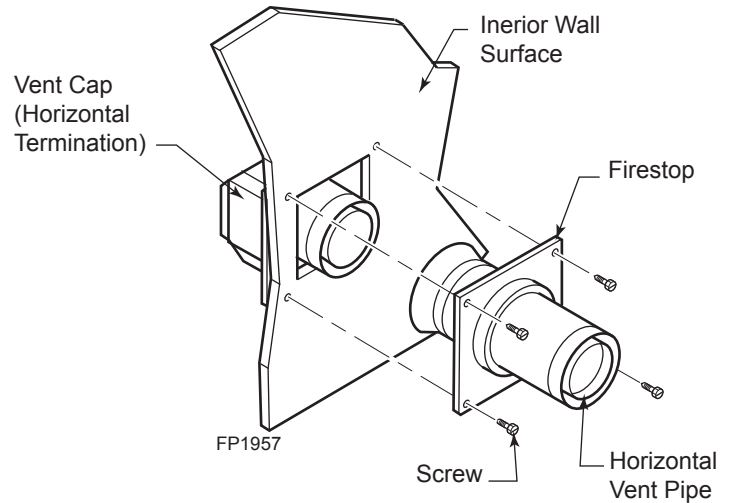
**NOTE: Replace the wood screws with appropriate fasteners for stucco, brick, concrete or other types of siding.**

For vinyl siding, stucco or wood exterior, use vinyl siding standoffs between vent cap and exterior wall for Simpson or Selkirk Terminations only. The vinyl siding standoff prevents excessive heat from melting the vinyl siding material. **NOTE: MHSC Termination does not require standoff. Bolt the vent cap to the standoff or wall. Apply non-hardening mastic around outside edge of the standoff instead of the vent cap assembly. Use wood screws provided to attach the standoff. *Figure 18***

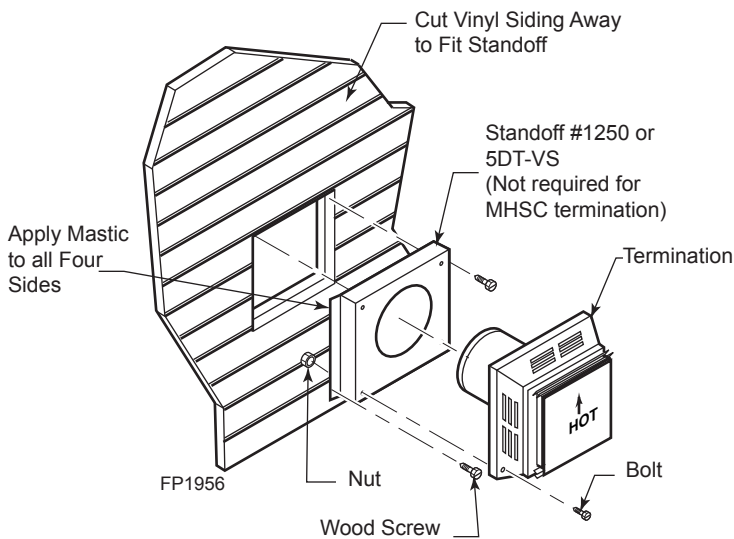




**Figure 17 -  
Install Horizontal Termination**



**Figure 19 -  
Install Firestop on Horizontal Vent Pipe**



**Figure 18 -  
Install Simpson/Selkirk Vinyl Siding Standoff and Termination**

6. Slide the stop over the vent pipe before connecting the horizontal run to the vent cap. *Figure 19*
7. Carefully move the fireplace with vent assembly attached toward the wall and insert the vent pipe into the horizontal termination. The pipe overlap should be a minimum of 1<sup>1</sup>/<sub>4</sub>". Apply silicone to the outer pipe connection. Fasten all vent connections with screws provided.
8. Slide the wall thimble against the interior wall surface and attach with screws. *Figure 19*

**WARNING**  
Do not recess vent termination into any wall. This will cause a fire hazard.

**NOTICE**  
For more information, follow instructions provided with terminations.

**HORIZONTAL WITH VERTICAL RISE  
(THROUGH-THE-WALL)  
TERMINATION CONFIGURATIONS**

Since it is very important that the venting system maintain its balance between the combustion air intake and the flue gas exhaust, certain limitations as to vent configurations apply and must be strictly adhered to.

The Vent Graph, showing the relationship between vertical and horizontal side wall venting, will help to determine the various dimensions allowable. *Figure 13*

Minimum clearance between vent pipes and combustible materials is 3" on top and 1" from bottom and sides unless otherwise noted (Exception: Outside wall with firestop: 1" all around pipes are allowed). If the vertical run is 7<sup>1</sup>/<sub>2</sub> feet or more, off the top of the fireplace, the clearance is 1" on all sides of the horizontal run.

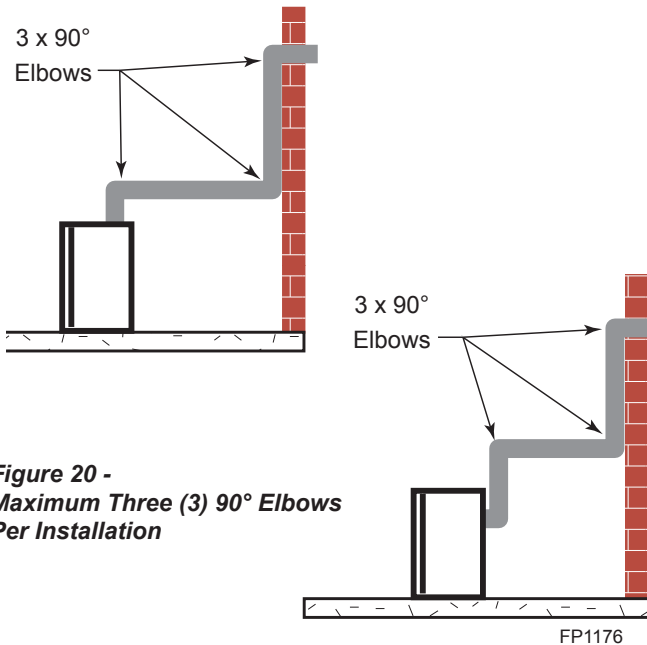
When vent termination exits through foundations less than 20" below siding outcrop, the vent pipe must be flush with the siding.

It is best to locate the fireplace in such a way that minimizes the number of offsets and horizontal vent length.

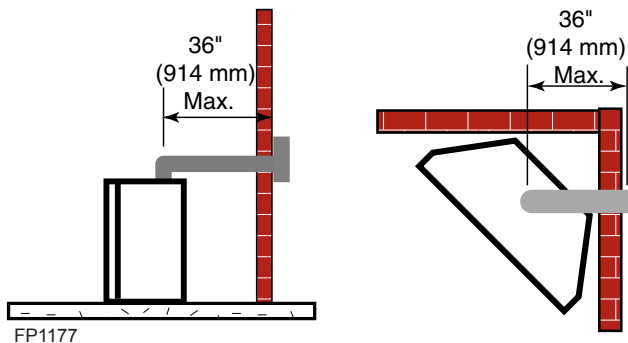
**NOTICE**  
All rear vent through-the-wall applications must use MHSC-designed 5 x 8 square termination. No other manufacturer's termination is permitted in this application.

The horizontal vent run refers to the total length of vent pipe from the flue collar of the fireplace (or the top of the Transition Elbow) to the face of the finished outside wall or the mounting flange of the termination.

- The maximum number of 90° elbows per side wall installation is three (3). *Figure 20*
- If a 90° elbow is fitted directly on the top of the fireplace, the maximum horizontal vent run before the termination or a vertical rise is 36" (914 mm). *Figure 21*



**Figure 20 -**  
Maximum Three (3) 90° Elbows  
Per Installation



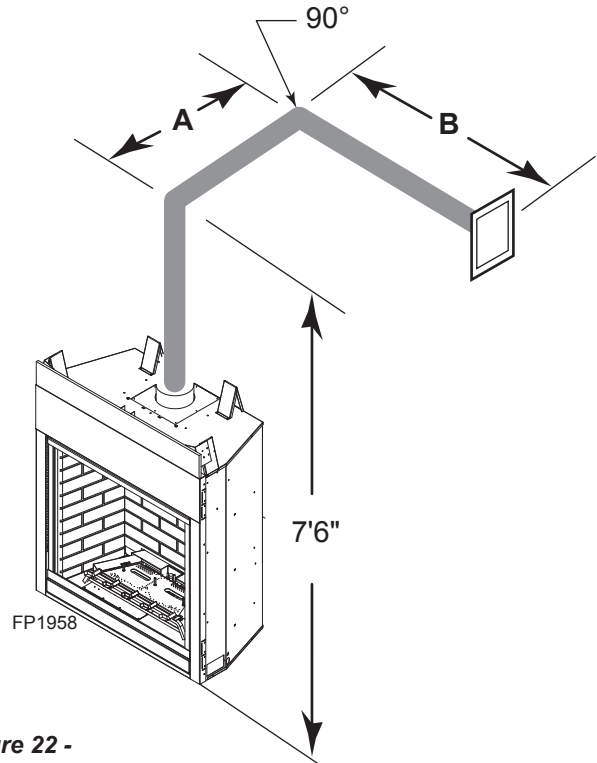
**Figure 21 -**  
Maximum Horizontal Run with No Rise

**WARNING** When installing the appliance as a rear vent unit, the 90° or 45° transition elbow attached directly to the rear of the unit is NOT INCLUDED in the following criteria and calculations and, unless specifically mentioned, should be ignored when calculating venting layouts.

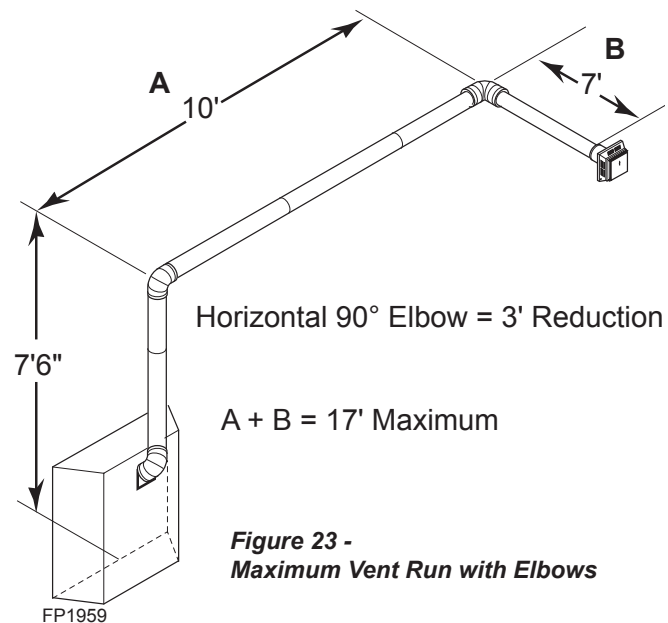
- If a 90° elbow is used in the horizontal vent run (level height maintained) the horizontal vent length is reduced by 36". *Figure 23*. This does not apply if the 90° elbows are used to increase or redirect a vertical rise. *Figure 22*

**Example:** According to the vent graph (Page 17) the maximum horizontal vent length in a system with a 7.5' vertical rise is 20' (6 m) and if a 90° elbow is required in the horizontal vent it must be reduced to 17' (5.2 m).

In *Figures 22 and 23* dimension A plus B must not be greater than 17' (5.2 m).



**Figure 22 -**  
Horizontal Run Reduction

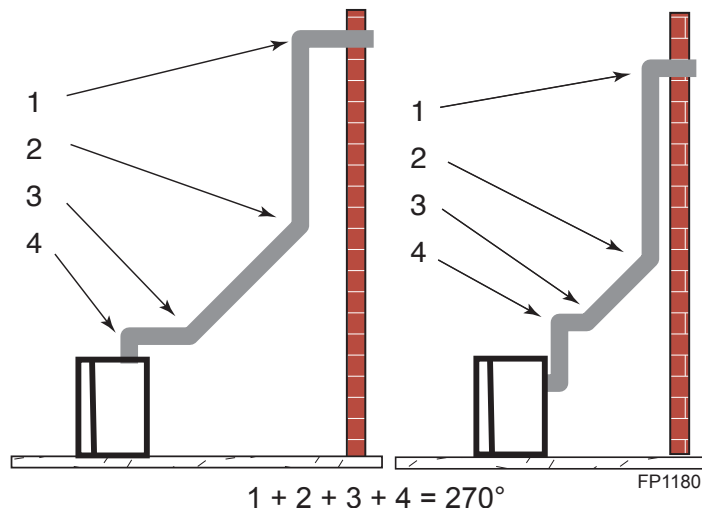


**Figure 23 -**  
Maximum Vent Run with Elbows

- For each 45° elbow installed in the horizontal run, the length of the horizontal run **MUST** be reduced by 18" (457 mm). This does not apply if the 45° elbows are installed on the vertical part of the vent system.
- The maximum number of elbow degrees in a system is 270°. *Figure 24*

*Example:*

Elbow 1 =	90°
Elbow 2 =	45°
Elbow 3 =	45°
Elbow 4 =	90°
<b>Total Angular Variation = 270°</b>	



*Figure 24 - Maximum Elbow Usage*

**HORIZONTAL WITH VERTICAL RISE (THROUGH-THE-WALL) APPLICATIONS**

1. Locate and cut the vent opening in the wall. For combustible walls first frame in opening.

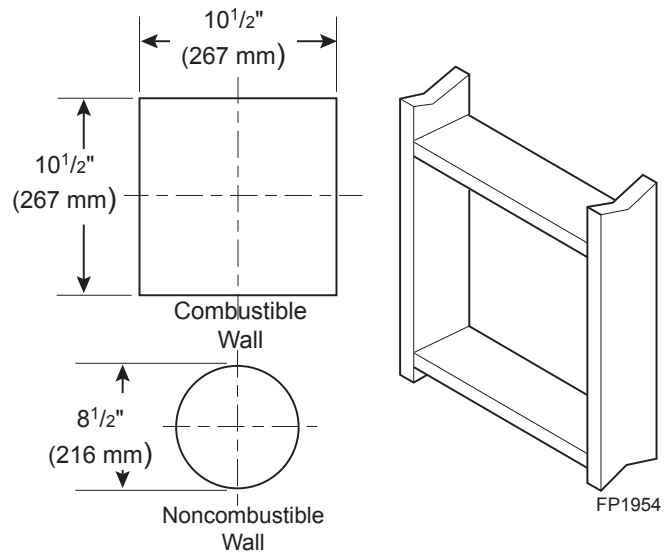
**Combustible Interior Walls:** Cut a 12½"H x 10½" W hole through the interior wall.

**Combustible Exterior Walls:** Cut a 10½"H x 10½"W square hole through the exterior wall frame. *Figure 25*

**Noncombustible Walls:** Hole opening should be 8½" (216 mm) in diameter.

2. The center of the hole should line up with the center line of the horizontal rigid vent pipe end. Allow ¼" minimum rise per foot. *Figure 25*

**NOTE:** #1222DA reducer must be used when 4x6⅝" venting is preferred. The 7TDVP58 reducer must be used when 4" x 7" venting is preferred. Reducer must be installed directly onto unit at the fireplace collar before vertical rise.



*Figure 25 - Exterior Wall Framing Dimensions for 5" x 8"*

**WARNING**

You may use a reducer from 5" x 8" to 4" x 6⅝" or 4" x 7" for horizontal with vertical rise applications. **ONLY** use framing instructions below when using 4" x 6⅝" or 4" x 7" venting.

If the reducer is installed at the rear of the unit, you must immediately follow with a 90° elbow for a vertical rise before continuing with any horizontal run. There is a minimum total height of 7 feet from the fireplace floor to the last section of pipe before horizontal run. Refer to graph on Page 17.

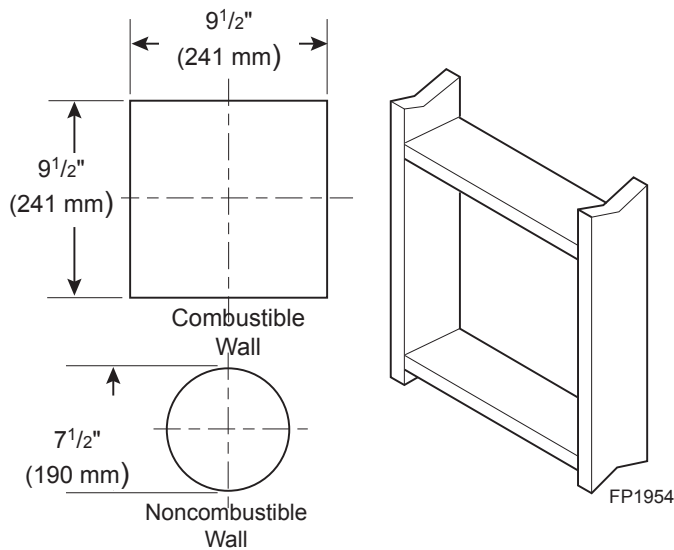
1. Locate and cut the vent opening in the wall. For combustible walls first frame in opening.

**Combustible Interior Walls:** Cut a 11½"H x 9½" W hole through the interior wall.

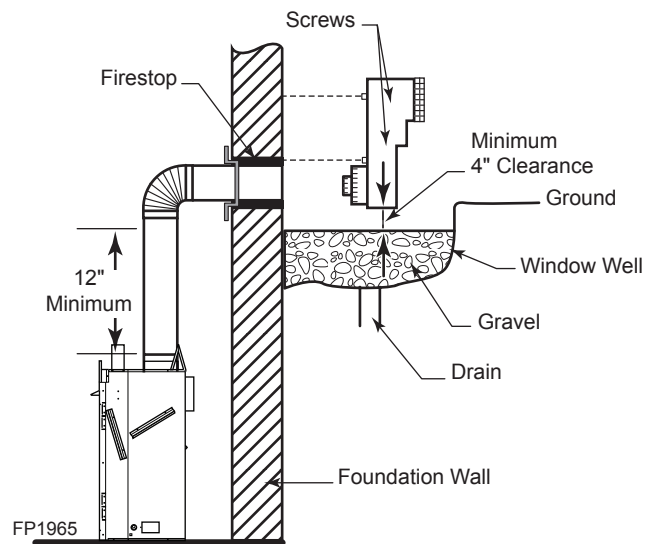
**Combustible Exterior Walls:** Cut a 9½"H x 9½"W square hole through the exterior wall frame. *Figure 26*

**Noncombustible Walls:** Hole opening should be 7½" (190 mm) in diameter.

2. The center of the hole should line up with the center line of the horizontal rigid vent pipe end. Allow ¼" minimum rise per foot. *Figure 26*



**Figure 26 -**  
**Exterior Wall Framing Dimensions**  
**for 4" x 6<sup>5</sup>/<sub>8</sub>" or 4" x 7"**



**Figure 27 -**  
**Below Grade Installation**

## BELOW GRADE INSTALLATIONS

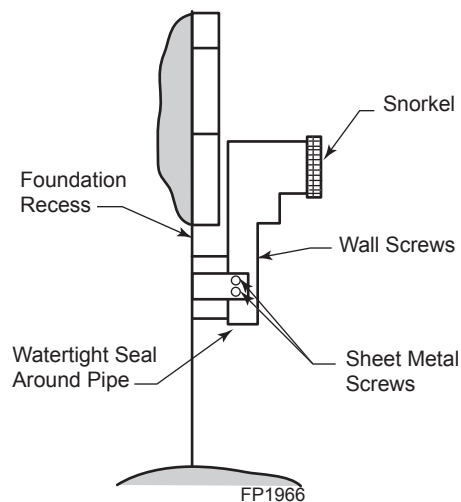
When it is not possible to meet the required vent terminal clearances of 12" above grade level, a snorkel kit is recommended. It allows installation depth down to 7" (178 mm) below grade level. The 7" (178 mm) is measured from the center of the horizontal vent pipe as it penetrates through the wall.

**Ensure that sidewall venting clearances are observed. If venting system is installed below ground, we recommend a window well with adequate and proper drainage to be installed around the termination area.**

If installing a snorkel, a minimum 24" vertical rise is necessary. The maximum horizontal run with the 24" vertical pipe is 36". This measurement is taken from the collar of the fireplace (or transition elbow) to the face of the exterior wall. Refer to the Sidewall Venting Graph for extended horizontal run if the vertical exceeds 24".

1. Establish vent hole through the wall.
2. Remove soil to a depth of approximately 16" below base of snorkel. Install drain pipe. Install window well (not supplied). Refill hole with 12" of coarse gravel leaving a clearance of approximately 4" below snorkel. *Figure 27*
3. Install vent system.
4. Ensure a watertight seal is made around the vent pipe coming through the wall.
5. Apply high temperature sealant caulking (supplied) around the 5" and 8" snorkel collars.
6. Slide the snorkel into the vent pipes and secure to the wall.
7. Level the soil so as to maintain a 4" clearance below snorkel. *Figure 27*

If the foundation is recessed, use recess brackets (not supplied) for securing lower portion of the snorkel. Fasten brackets to wall first, then secure to snorkel with self drilling #8 x 1/2 sheet metal screws. It will be necessary to extend vent pipes out as far as the protruding wall face. *Figure 28*



**Figure 28 -**  
**Snorkel Installation, Recessed Foundation**

**WARNING**

- Do not back fill around snorkel.
- A clearance of at least 4" must be maintained between the snorkel and the soil.

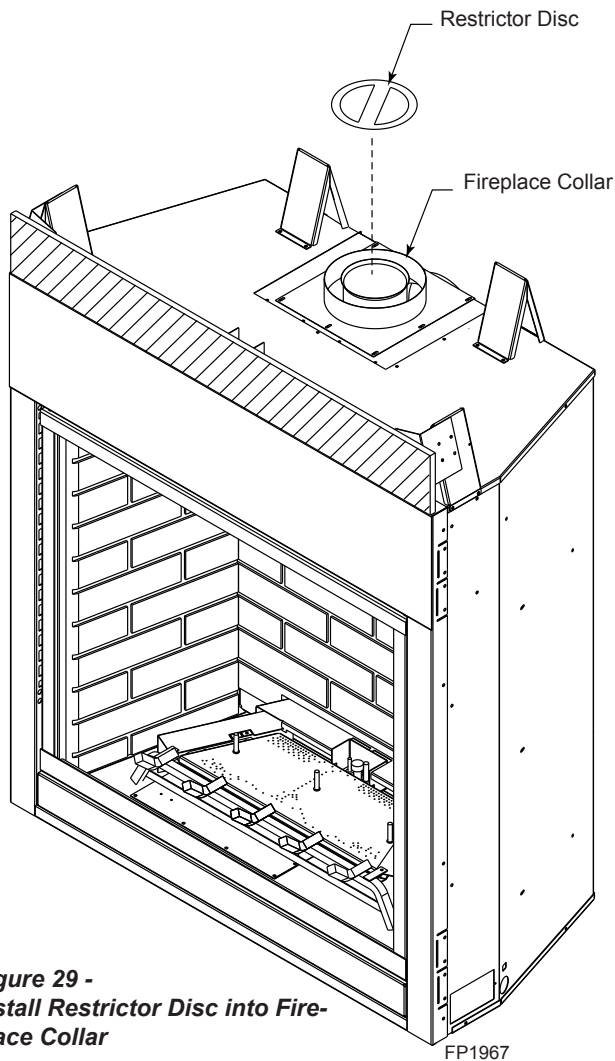
**VERTICAL THROUGH-THE-ROOF APPLICATIONS**

Install restrictor disc as shown in *Figure 29* for vertically vented applications.

Up to two (2) restrictor discs may be needed for 40' installation.

The two (2) restrictor discs supplied will work for most installations. If a third disc is needed order Part No. 56D3027.

You may use a reducer to 4" x 6<sup>5</sup>/<sub>8</sub>" or 4" x 7" in vertically vented applications. If a reducer is used, only one restrictor may be used.

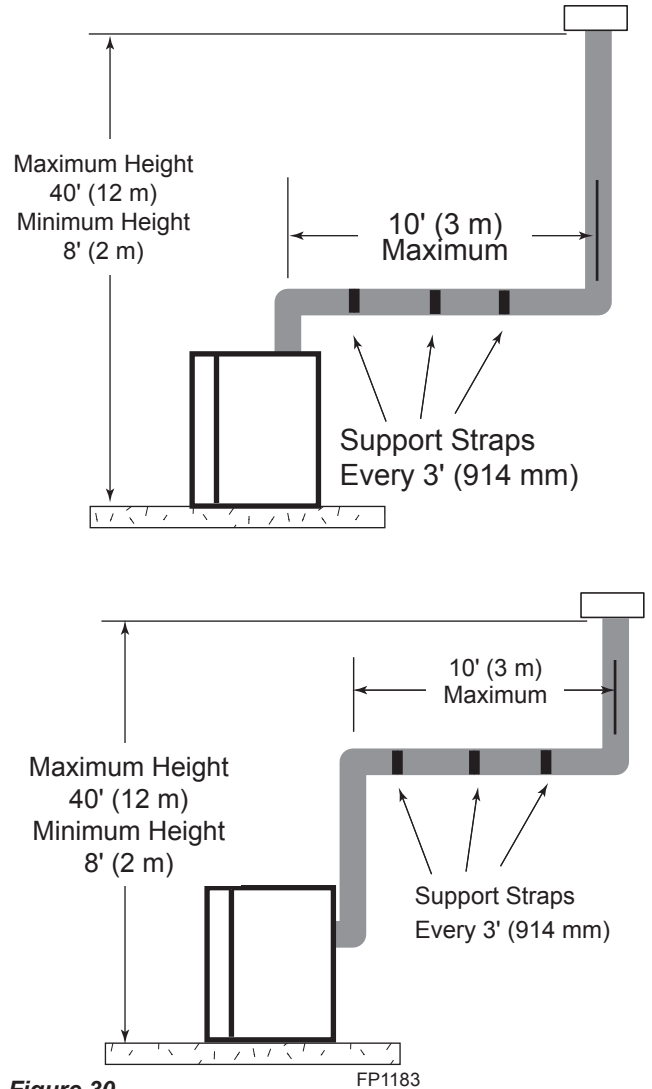


**Figure 29 -  
Install Restrictor Disc into Fire-  
place Collar**

**NOTICE** A restrictor disc must be installed on any vertical termination that is higher than 12'.

This Gas Fireplace has been approved for,

- Vertical installations up to 40' (12 m) in height. Up to a 10' (3 m) horizontal vent run can be installed within the vent system using a maximum of two 90° elbows. *Figure 30*



**Figure 30 -  
Support Straps for Horizontal Runs**

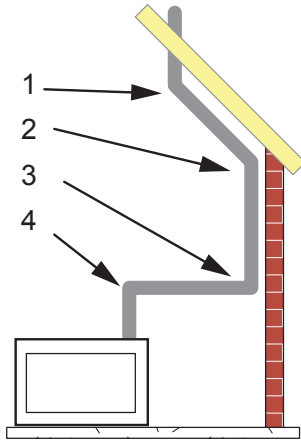
- Up to two 45° elbows may be used within the horizontal run. For each 45° elbow used on the horizontal plane, the maximum horizontal length must be reduced by 18" (450 mm).

*Example:* Maximum horizontal length

No elbows	= 10' (3 m)
1 x 45° elbows	= 8.5' (2.6 m)
2 x 45° elbows	= 7' (2.1 m)

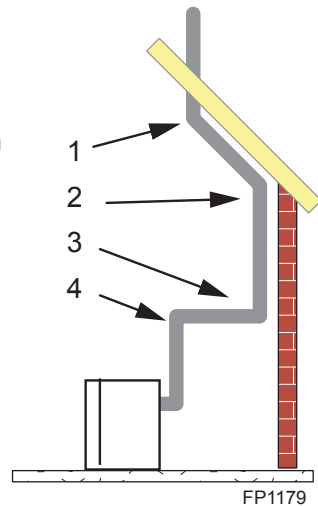
- A minimum of an 8' (2.5 m) vertical rise is required.

- Two sets of 45°elbows offsets may be used within the vertical sections. From 0 to a maximum of 8' (2.5 m) of vent pipe can be used between elbows. *Figure 31*
- Determine the roof pitch and use the appropriate starter kit for offset installation.
- The maximum angular variation allowed in the system is 270°. *Figure 31*
- For the minimum height of the vent above the highest point of penetration through the roof refer to Page 25, Figure 35.



Example: Elbow 1 = 90°  
 Elbow 2 = 45°  
 Elbow 3 = 45°  
 Elbow 4 = 90°  
 Total Angular Variation = 270°

Figure 31 - Maximum Elbow Usage



### INSTALLATION FOR VERTICAL TERMINATION

1. Determine the route your vertical venting will take. If ceiling joist, roof rafters or other framing will obstruct the venting system, consider an offset. Refer to *Figure 32* to avoid cutting load bearing members.

**NOTE:** Pay special attention to these installation instructions for required clearances (air space) to combustibles when passing through ceilings, walls, roofs, enclosures, attic rafters, etc. Do not pack air spaces with insulation. Also note maximum vertical rise of the venting system and any maximum horizontal offset limitations. Offsets must fall within the parameters shown on *Page 17, Figure 13*.

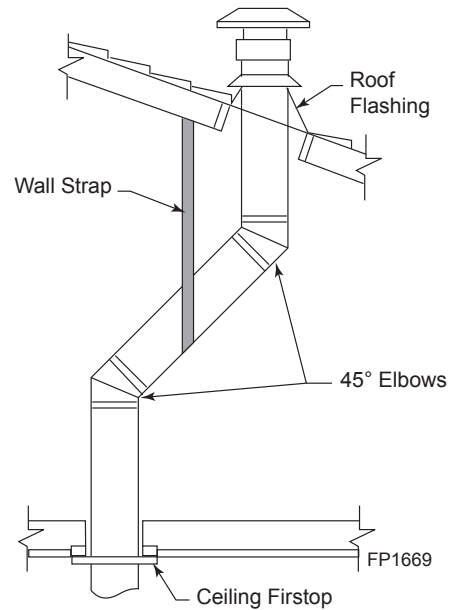


Figure 32 - Offset with Wall Strap and 45° Elbows

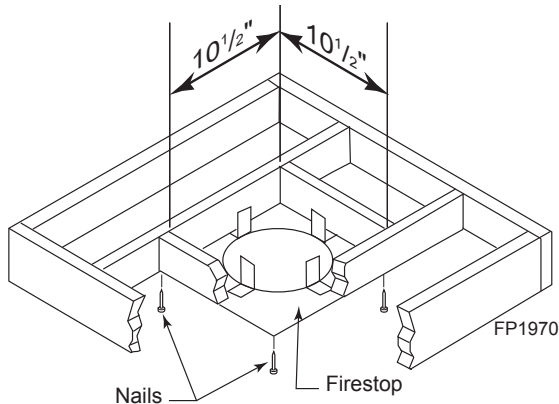
2. Set fireplace in desired location. Drop a plumb line down from the ceiling to the position of the flue exit. Mark the center point where the vent will penetrate the ceiling. Drill a small locating hole at this point.  
 Drop a plumb line from the inside of the roof to the locating hole in the ceiling. Mark the center point where the vent will penetrate the roof. Drill a small locating hole at this point.

### FLAT CEILING INSTALLATION

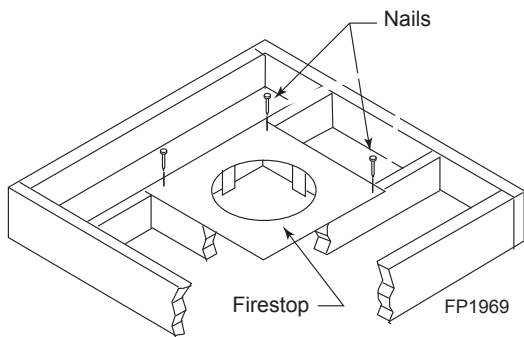
1. Cut a 10½" (267 mm) square hole in the ceiling using the locating hole as a center point. The opening should be framed to 10½" x 10½" (267 x 267 mm) inside dimensions as shown in *Figure 33* using framing lumber the same size as the ceiling joist. If the area above the ceiling is an insulated ceiling or a room, nail firestop from the top side. This prevents loose insulation from falling into the required clearance space. *Figure 34*.

Otherwise, install firestop below the framed hole. The firestop should be installed with no less than three (3) nails per side. *Figure 34.*

- Assemble the desired lengths of pipe and elbows necessary to reach from the burner system flue up through the firestop. Be sure pipe and elbow connections are fully twist-locked. *Page 18, Figure 15.*



**Figure 33 -**  
**If Area Above is Not a Room, Install Firestop**  
**above Framed Hole as Shown**



**Figure 34 -**  
**If Area Above is a Room, Install Firestop**  
**above Framed Hole as Shown**

- Cut a hole in the roof using the locating hole as a center point. (Cover any exposed open vent pipes before cutting hole in roof). The 10 1/2" x 10 1/2" (267 x 267 mm) hole must be measured on the horizontal. Actual length may be larger depending on the pitch of the roof. There must be a 1" minimum clearance from the vent pipe to combustible materials. (Insulation should be considered a combustible material). Frame the opening as shown on *Page 18, Figure 16.*

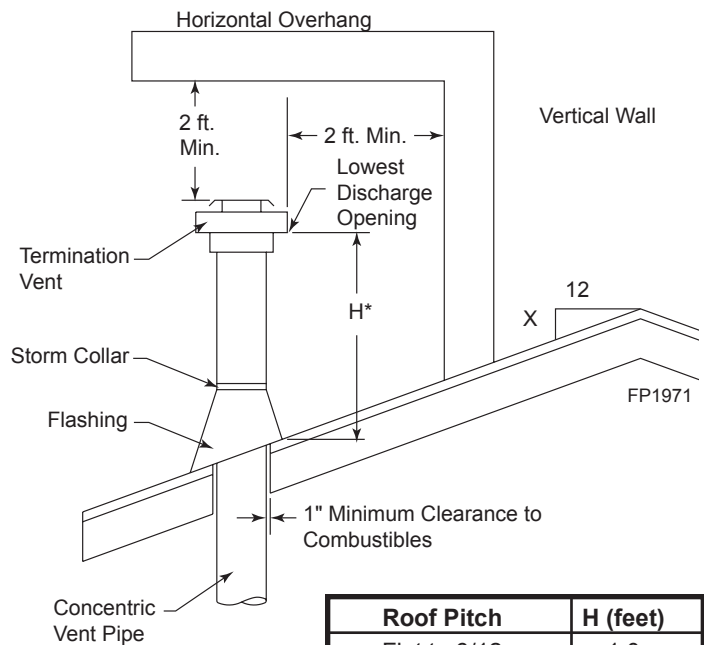
- Connect a section of pipe and extend up through the hole.

**NOTE:** If an offset is needed to avoid obstructions, you must support the vent pipe every three (3) feet. Use wall straps for this purpose. *Figure 32.* Whenever possible, use 45° elbows instead of 90° elbows. The 45° elbow offers less restriction to the flow of the flue gases and intake air.

- Place the flashing over the pipe section(s) extending through the roof. Secure the base of the flashing to the roof and framing with roofing nails. Be sure roofing material overlaps the top edge of the flashing. There must be a 1" clearance from the vent pipe to combustible materials.
- Continue to add pipe sections until the height of the vent cap meets the minimum requirements below.

**NOTE:** You must increase vent height for steep roof pitches. Nearby trees, adjoining roof lines, steep pitched roofs, and other similar factors may cause poor draft or down-drafting in high winds. Increasing the vent height may solve this problem.

**NOTE:** If the vent pipe passes through any occupied areas above the first floor, including storage spaces and closets, you must enclose pipe. You may frame and sheetrock the enclosure with standard construction material. Make sure to meet the minimum allowable clearances to combustibles. Do not fill any of the required clearance spaces with insulation.



Roof Pitch	H (feet)
Flat to 6/12	1.0
Over 6/12 to 7/12	1.25
Over 7/12 to 8/12	1.5
Over 8/12 to 9/12	2.0
Over 9/12 to 10/12	2.5
Over 10/12 to 11/12	3.25
Over 11/12 to 12/12	4.0

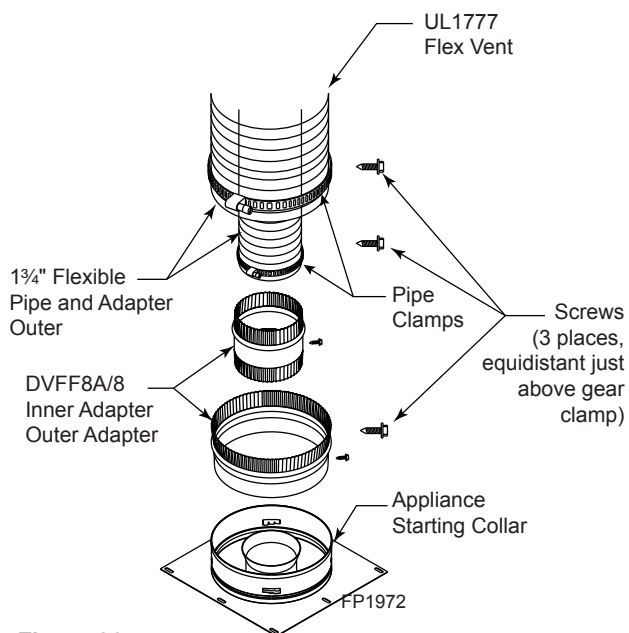
\*H - Minimum height from roof to lowest discharge opening of vent

**Figure 35 -**  
**Minimum Chimney Clearance**

1. Flexible UL1777 listed venting may be used in any venting application where rigid direct vent components can be used. **All restrictions, clearances and allowances that pertain to the rigid piping apply to the flexible venting.** Flex kits may not be modified. Flex kits may be added to the end of a vent run made of rigid vent sections using pipe manufacturer's approved flex to pipe adapters. This may occur only if doing so does not violate any of the venting length, height, routing, horizontal to vertical ratio requirements or clearance considerations detailed in this manual.

### 5" x 8" Flex Vent Pipe

2. The flex adapter starter kit (DVFF8A/8) is used to attach flex venting to the appliance starting collar. It includes 5" inner and 8" outer adapter rings. *Figure 36*
  - The inner and outer adapter rings are required to start all flex runs.
  - Never install damaged or torn flexible venting.
  - Over tightening clamps may rip, tear, or otherwise damage flexible venting.
  - The adapter kit does not include individual pipe sections which may be purchased separately. (UL1777 listed type venting only.)
3. Start the flexible vent as follows:
  - A. Installing the inner flex adapter and pipe. *Figure 36*

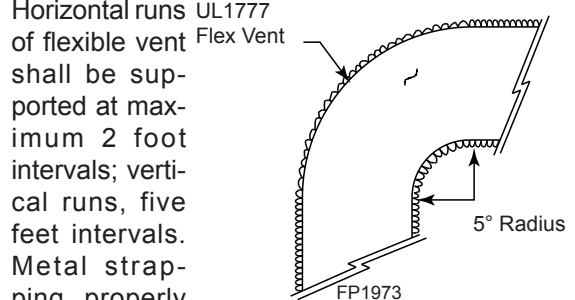


**Figure 36 -  
Typical Appliance Connection**

**NOTE**

**Flex vent pipe spacers: Refer to manufacturer's specifications for correct positioning of the spacer springs to maintain proper distance between inside and outside pipe.**

1. Insert the long side of the 5" inner ring into exhaust pipe, gently tap to seat into place, and secure with screws.
  2. Slide the small gear clamp over the inner flexible vent pipe, and push out of the way.
  3. Pull and extend the inner flexible vent.
  4. Slide the inner vent onto the adapter collar, for a minimum 1 $\frac{3}{4}$ " overlap.
  5. Locate the clamp at approximately 3/4" from the flex end and tighten.
  6. Secure the clamped inner section with three self-tapping screws, drilled equidistant, just above the clamp perimeter.
- B. Installing the outer flex pipe. *Figure 36*
    1. Firmly insert the 8" outer adapter ring into the outer appliance starting collar and secure with screws.
    2. Slide the large gear clamp over the outer flexible vent pipe, and push out of the way.
    3. Pull and extend the outer flexible vent.
    4. Slide the outer vent onto the appliance collar outer adapter for a minimum 1 $\frac{3}{4}$ " overlap.
    5. Locate the clamp at approximately 3/4" from the flex end and tighten.
    6. Secure the clamped outer section with three self-tapping screws, drilled equidistant, just above the clamp perimeter.
- C. Routing UL1777 flex pipe.
    1. Always maintain the required clearance when routing the flex vent assembly.
    2. Install firestop spacers, *Figure 38*, when penetrating ceiling, attic spaces, or walls.
    3. Do not allow the flexible vent to bend in radius tighter than 5" (127 mm). *Figure 37*
    4. Horizontal runs of flexible vent shall be supported at maximum 2 foot intervals; vertical runs, five feet intervals. Metal strapping, properly secured, is an acceptable means to support the flexible vent.



**Figure 37 -  
Minimum Radius for Flex  
Vent Section**

5. Flexible vent spacers are to be installed at intervals prescribed by the flexible vent manufacturer; and in such a way as to maintain concentric inner and outer vent spacing.

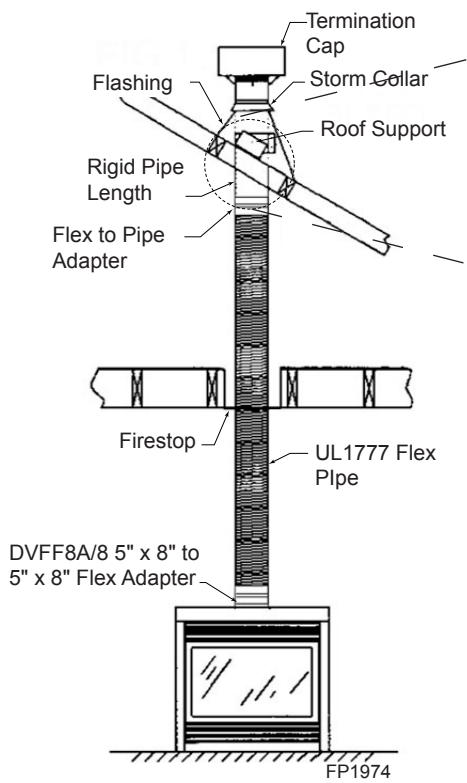


**D. Attaching flexible venting to vertical termination assemblies.**

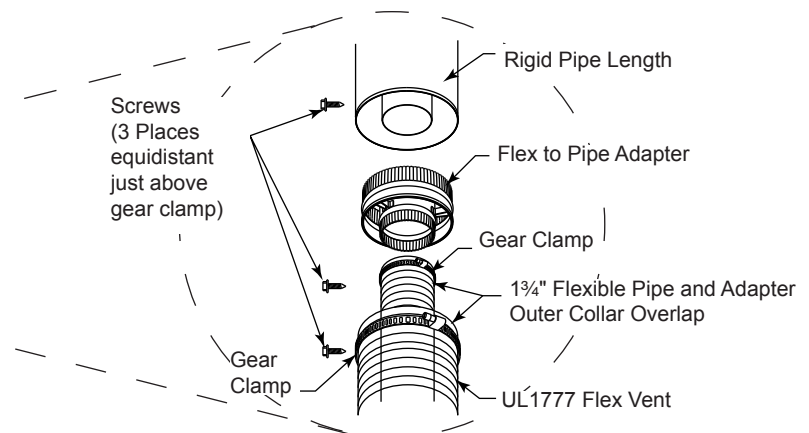
1. When using Simpson pipe, an MHSC flex-to-pipe adapter and/or rigid pipe section(s) is required to connect the flexible vent assembly to the vertical termination by using three self-penetrating screws.
2. Review *Figure 39* and corresponding instructions for proper overlap, clamp and screw placement.
3. Three each self-penetrating screws are drilled opposite one another and below the gear clamp.
4. Use only listed and approved terminations and accessories, installed per the installation instructions and *Figure 38*.

**E. Installing flexible venting to horizontal termination assemblies.**

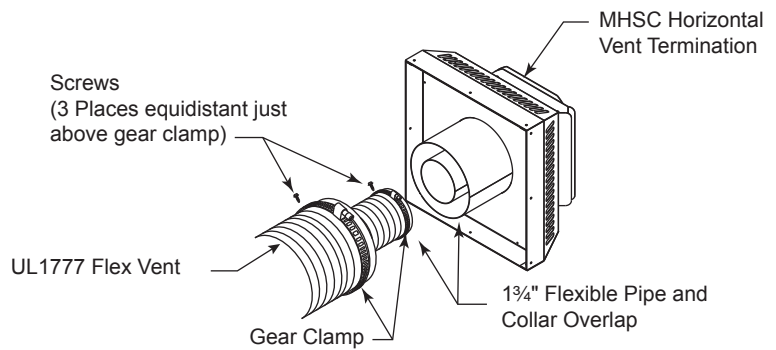
1. Connect the 5" flexible vent to the horizontal termination as in *Figure 40*.
2. Connect the 8" flexible vent to the termination ring as in *Figure 40*.
3. Review *Figure 40* for proper overlap and clamp placement.
4. Three each self-penetrating screws are drilled opposite one another and below the gear clamp.
5. Use only listed and approved terminations and accessories, installed per the termination instructions and *Figure 40*.



**Figure 38 - Typical Vertical Flex Vent Installation**



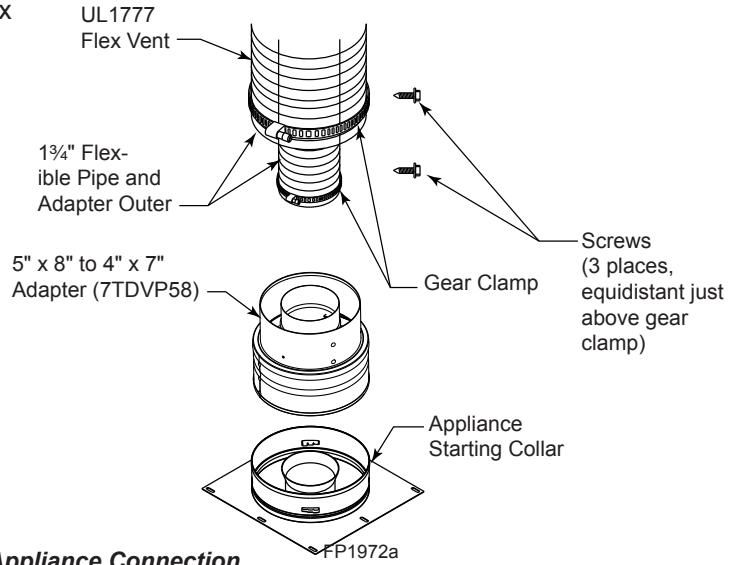
**Figure 39 - Typical Pipe Connection**



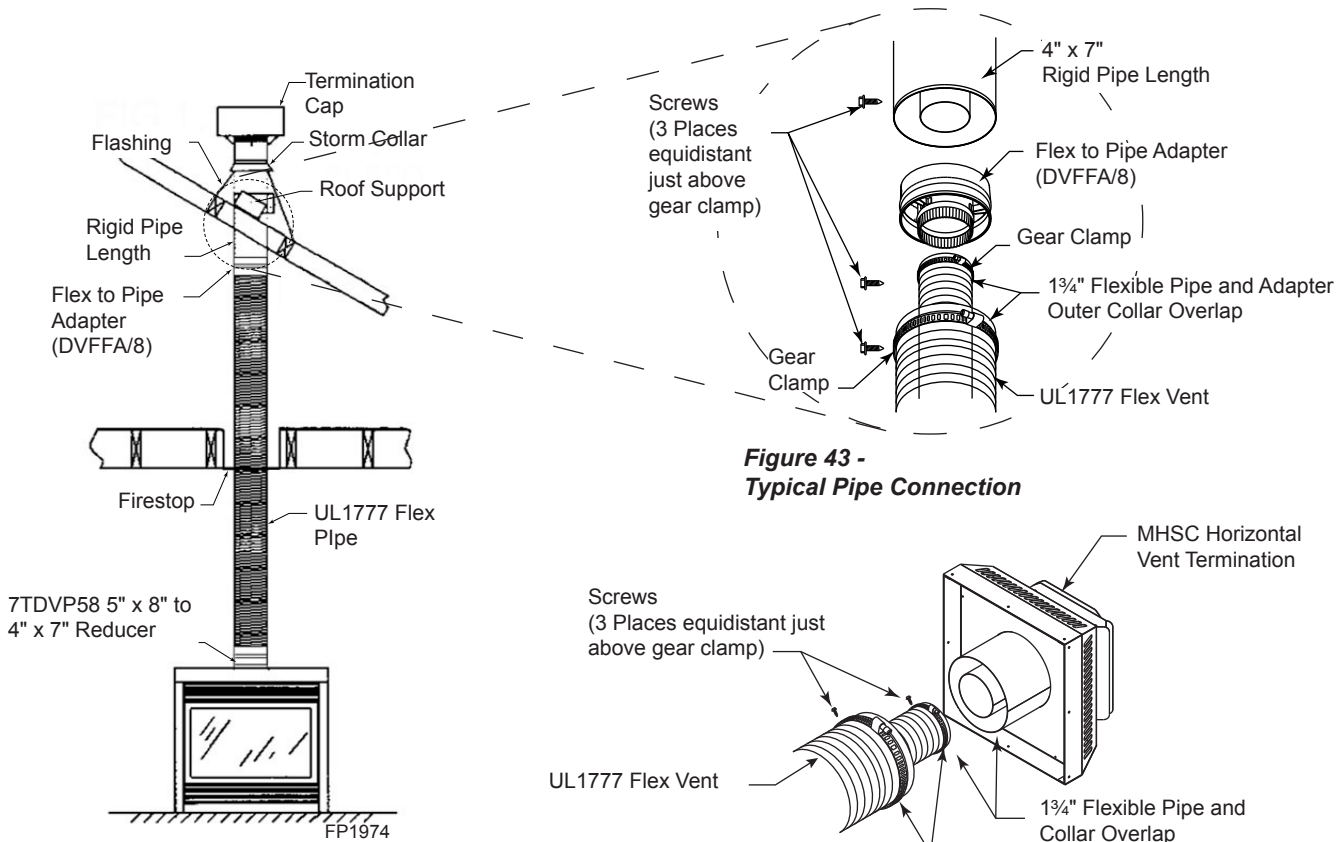
**Figure 40 - Typical Horizontal Flex Vent Installation**

**4" x 7" Flex Pipe**

If you prefer to use 4" x 7" flex pipe, you must install model 7TDVP58 reducer (5" x 8" to 4" x 7") onto the fireplace collar. Then follow the assembly guidelines for 5" x 8" flex venting.



**Figure 41 - Typical 4" x 7" Appliance Connection**



**Figure 42 - Typical Vertical Flex Vent Installation**

**Figure 43 - Typical Pipe Connection**

**Figure 44 - Typical Horizontal Flex Vent Installation**

**CHECK GAS TYPE**

Use proper gas type for the fireplace you are installing. If you have conflicting gas type, do not install fireplace. See dealer where you purchased the fireplace for proper fireplace for your gas type or conversion kit.

**INSTALLING GAS PIPING TO FIREPLACE / BURNER SYSTEM LOCATION**

**WARNING** A qualified installer or service person must connect appliance to gas supply. Follow all local codes.

**INSTALLATION ITEMS NEEDED**

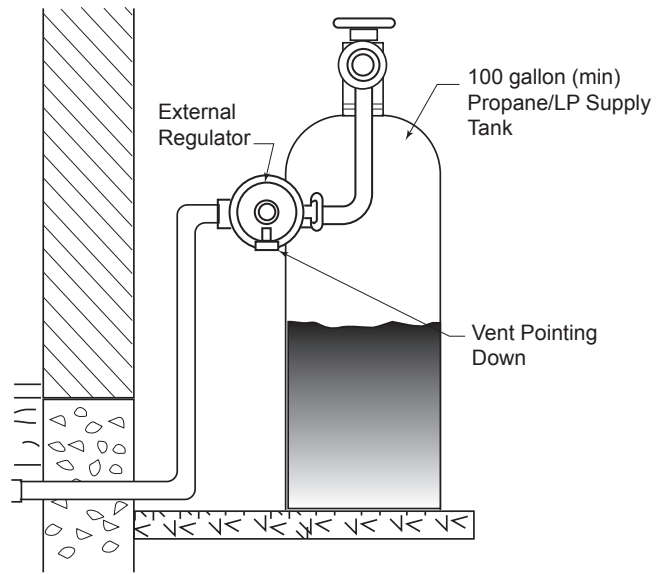
Before installing fireplace and burner system, make sure you have the items listed below.

- Tee joint
- Equipment shutoff valve\*
- Sediment trap (recommended)
- External regulator (supplied by installer)
- Piping (check local codes)
- Sealant (resistant to propane/LP gas)
- approved flexible gas line with gas connector (if allowed by local codes — not provided)
- Pipe wrench
- Test gauge connection\*

\* A CSA design-certified equipment shutoff valve with 1/8" NPT tap is an acceptable alternative to test gauge connection. Purchase the CSA design-certified equipment shutoff valve from your dealer.

For propane/LP connections only, the installer must supply an external regulator. The external regulator will reduce incoming gas pressure. You must reduce incoming gas pressure to between 11 and 13 inches of water. If you do not reduce incoming gas pressure, burner system regulator damage could occur. Install external regulator with the vent pointing down as shown in *Figure 45*. Pointing the vent down protects it from freezing rain or sleet.

**CAUTION** For propane/LP units, never connect fireplace directly to the propane/LP supply. This burner system requires an external regulator (not supplied). Install the external regulator between the burner system and propane/LP supply.



**Figure 45 - External Regulator with Vent Pointing Down (Propane/LP Only)**

**CAUTION** Use only new black iron or steel pipe. Internally tinned copper or copper tubing can be used per National Fuel Code, Section 2.6.3, providing gas meets hydrogen sulfide limits, and where permitted by local codes. Gas piping system must be sized to provide minimum inlet pressure (listed on data plate) at the maximum flow rate (BTU/hr). Undue pressure loss will occur if the pipe is too small.

When using copper or flex connectors use only fittings approved for gas connections. The gas control inlet is 3/8" NPT.

**WARNING**

Only persons licensed to work with gas piping may make the necessary gas connections to this appliance.

**CAUTION**

A manual shutoff valve must be installed upstream of the appliance. Union tee and plugged 1/8" NPT pressure tapping point should be installed upstream of the appliance. *Figure 46*

**NOTE :** The gas line connection may be made using 1/2" rigid tubing or an approved flex connector. Since some municipalities have additional local codes it is always best to consult your local authorities and the current edition of the National Fuel Gas Code ANSI.Z223.1, NFPA54. In Canada CSA-B149 (1 or 2) Installation Code.

A listed manual shutoff valve must be installed upstream of the appliance. Union tee and plugged 1/8" NPT pressure tapping point should be installed upstream of the appliance. *Figure 46*

**IMPORTANT:** Install main gas valve (equipment shutoff valve) in an accessible location. The main gas valve is for turning on or shutting off the gas to the fireplace.

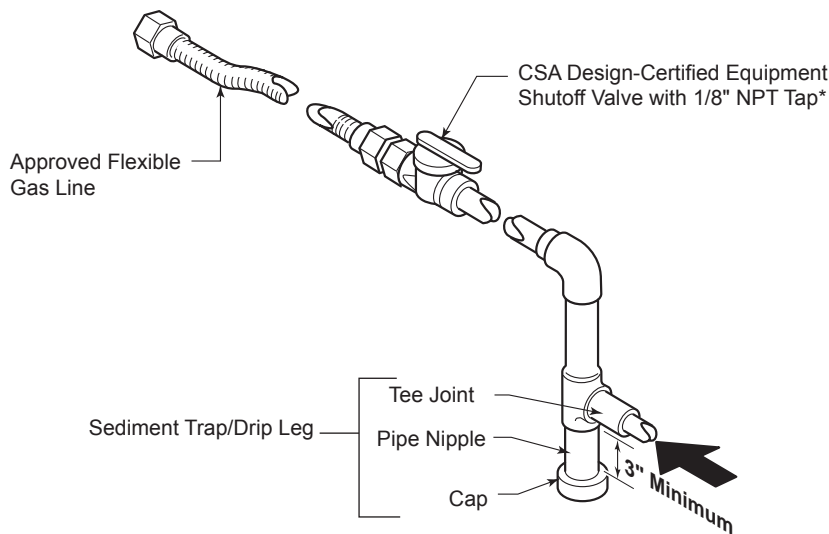
Check your building codes for any special requirements for locating equipment shutoff valve to fireplaces.

Apply pipe joint sealant lightly to male threads. This will prevent excess sealant from going into pipe. Excess sealant in pipe could result in clogged burner system valves

We recommend that you install a sediment trap/drip leg in supply line as shown in *Figure 46*. Locate sediment trap/drip leg where it is within reach for cleaning. Install in piping system between fuel supply and burner system. Locate sediment trap/drip leg where trapped matter is not likely to freeze. A sediment trap collects moisture and contaminants and keeps them from going into the burner system gas controls. If sediment trap/drip leg is not installed or is installed wrong, burner system may not run properly.

**CAUTION**

Use pipe joint sealant that is resistant to liquid petroleum (LP) gas.



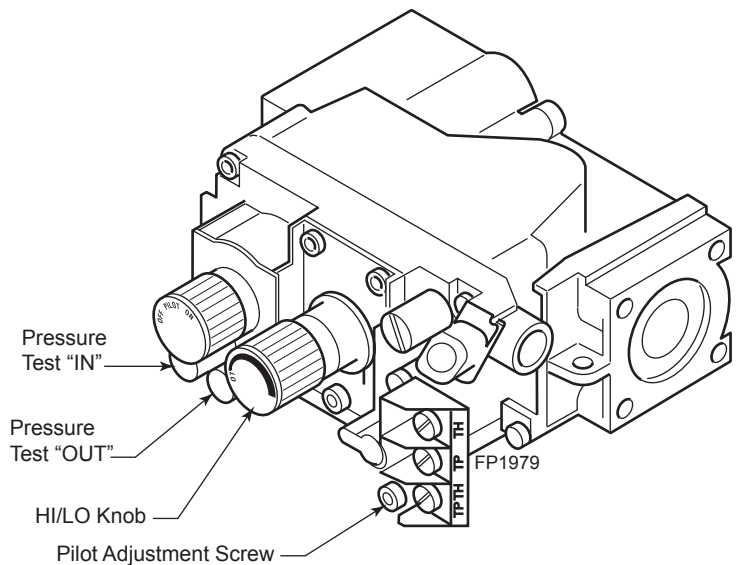
**Figure 46 - Gas Connection**

**Natural Gas**  
From Gas Meter  
(4.5" w.c. to 10.5" w.c. Pressure)

**Propane/LP**  
From External Regulator  
(11" w.c. to 13" w.c. Pressure)

## CHECK GAS PRESSURE and ELECTRICAL INSTALLATION - MILLIVOLT

1. Check gas type. The gas supply must be the same as stated on the appliance's rating decal. If the gas supply is different from the fireplace, STOP! Do not install the appliance. Contact your dealer immediately.
2. To ease installation, a 24" (610 mm) flex line with manual shut-off valve has been provided with on this appliance. Install and attach 1/2" gas line onto shut-off valve.
3. After completing gas line connection, purge air from gas line and test all gas joints from the gas meter to the fireplace for leaks. Use a solution of 50/50 water and soap solution or a gas sniffer.
4. To adjust flame height, turn HI/LO knob to HI to get maximum pressure to burner. Turn HI/LO knob to LO to get minimum pressure.
5. To check gas pressures at valve, turn captured screw counter clockwise 2 or 3 turns and then place tubing to pressure gauge over test point. Turn unit to high. *Figure 47* After taking pressure reading, be sure and turn captured screw clockwise firmly to reseal. Do not over torque. Check test points for gas leaks.



**Figure 47 -  
Gas Pressure Check at Gas Valve**

### ELECTRICAL WIRING

This fireplace will work without any electrical supply. Electricity is only needed to operate blower.

**NOTE:** If installed in mobile home, fireplace must be bolted securely to floor.

#### WARNING

Electrical connections should only be performed by a qualified, licensed electrician. Main power must be off when connecting to main electrical power supply or performing service. All wiring shall be in compliance with all local, city and state codes. The appliance, when installed, must be electrically grounded in accordance with local codes or in the absence of local codes, with the National Electrical Code ANSI/NFPA 70 (latest edition) and Canadian Electrical Code, CSA C22.1.

#### WARNING

Do not use open flame to check for gas leaks.

#### CAUTION

Label all wires before disconnecting when servicing controls. Wiring errors can cause improper and dangerous operation.

Verify proper operation after servicing.

**REMOTE WALL MOUNTED SWITCH**

A remote wall switch and up to fifteen (15) feet of 18 Ga. wire may be used with this appliance. Attach the wall switch in a junction box at the desired location on the wall. *Figure 48*. Do not extend beyond the wall switch wire length provided.

**NOTE:** Extended lengths of wire may cause the fireplace not to function properly. Longer length of wire is permitted if the wire is made out of larger gauge (diameter) wire. Always check with local code.

**WARNING** Do not connect wall switch 110V circuit.

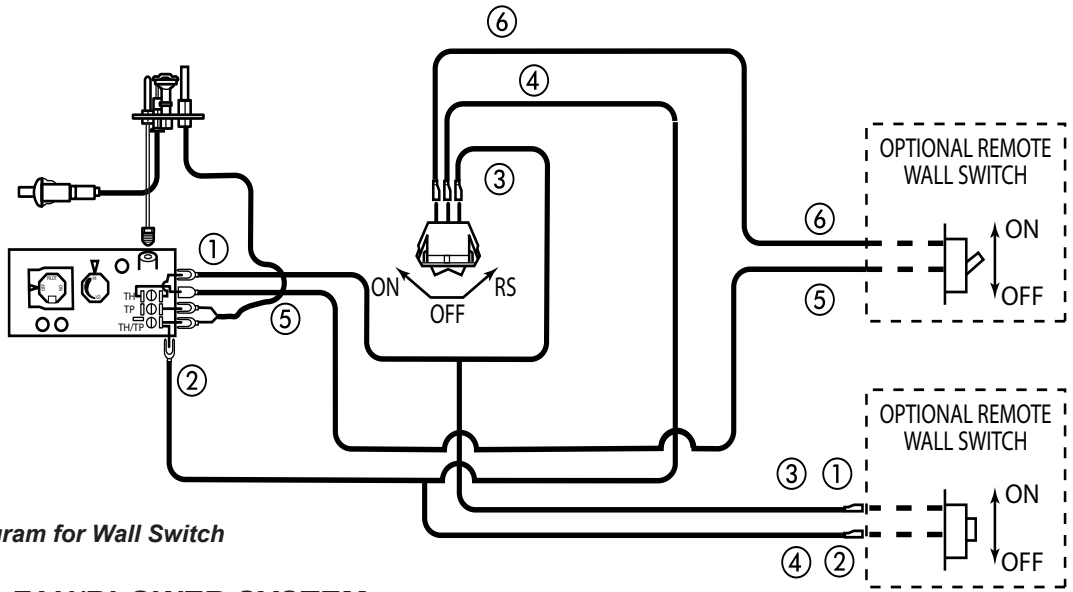


Figure 48 - Wiring Diagram for Wall Switch

**OPTIONAL FAN/BLOWER SYSTEM (BLOTBLDV)**

**Installation Instructions**

**Wiring**

1. Before installing the blower, wire the receptacle into an electrical circuit. This should be done before framing the fireplace. Wire with minimum 60° C wire in accordance with prevailing codes.
2. Remove the external junction box cover by removing the screw from the left side of the outside firebox wall. Junction box was installed at the factory.
3. The junction box cover has a factory installed "romex" style strain relief connector. After connecting the wires, route the wire leads through this connector. Refer to the wiring diagram in *Figure 49*.

**Before Installing the Blower**

1. Always turn off the gas supply and allow the unit to cool down before proceeding.
2. Clean the inside of the firebox (wall and floor), where the blower and wires will be installed. Make sure the firebox wall and floor are clean and dry before mounting the blower.

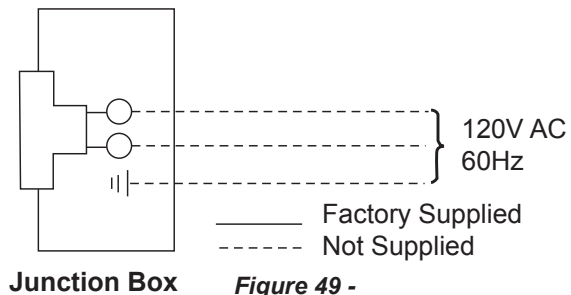
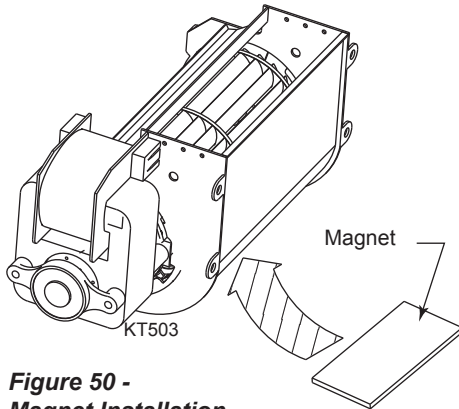


Figure 49 - Junction Box Wiring Diagram

**Install the Blower**

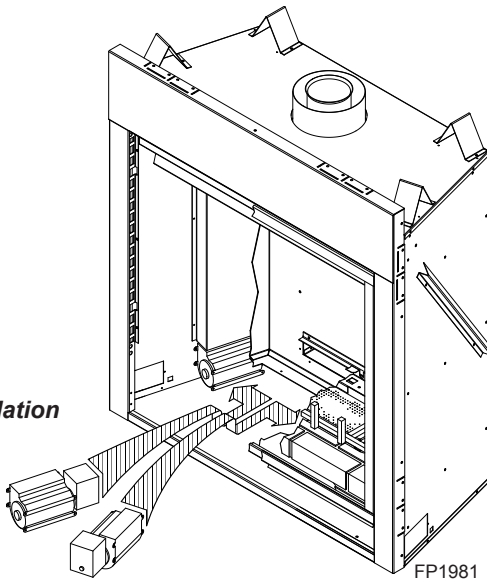
1. Remove the lower access panel by pulling up and away from unit.
2. Remove glass frame by releasing the two (2) latches (500 Model has three (3) latches) below the firebox opening and lifting glass frame up and away from unit.
3. Remove logs.
4. Remove grate from engine by lifting up.

5. Remove hearth brick and wall brick panels.
6. Disconnect the gas line to the valve.
7. Remove screws securing engine base to firebox floor and lift engine up to remove.
8. Two (2) magnetic strips have been supplied to secure each blower to the firebox floor. Place on bottom of each blower before installing. *Figure 50*
9. The blowers are to be inserted flat through the engine cutout in the firebox floor. Slide each blower over to the sidewall location. *Figure 51*

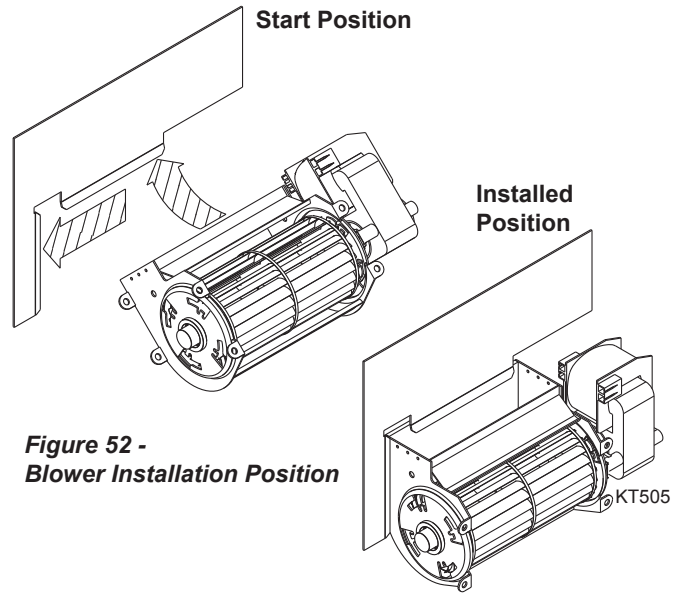


**Figure 50 - Magnet Installation**

**Figure 51 - Blower Installation**



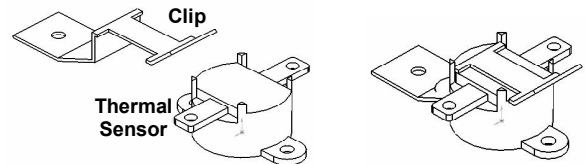
10. Turn blowers with discharge vent facing up. Slide the discharge vent so that it is facing up. Slip discharge vent flange under the flange bracket flush against the sidewall. Slide blower side tabs over into side flange. *Figure 52*. The blower is now locked in place.
11. Attach the speed control to the underside of the firebox using the supplied velcro, locating as far to the right or left as possible.
12. The thermal sensor clip is located beneath the firebox floor near the center. Slide the thermal sensor into the



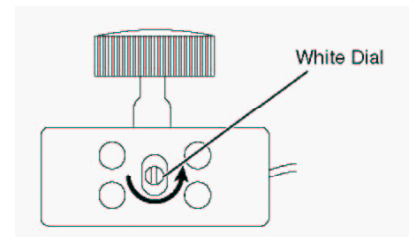
**Figure 52 - Blower Installation Position**

clip until it snaps in place. Make sure the terminals on the thermal sensor are perpendicular to the clip. *Figure 53*

**WARNING:** It is important to arrange the blower wire harness so the wires can not come in contact with blower fan blades.



**Figure 53 - Thermal Sensor Installation**



**Figure 54 - Location of White Dial on Speed Control**

13. Connect wiring according to the wiring diagram *Figure 55*.
14. Replace engine in reverse order of removal.
15. Plug in the blower.
16. Re-install firebrick, grate, logs, and glass door in reverse order of removal.
17. To test blower operation, set the variable speed blower on the LOW setting. Turn the fireplace on high. The blower should turn on within 10 minutes.

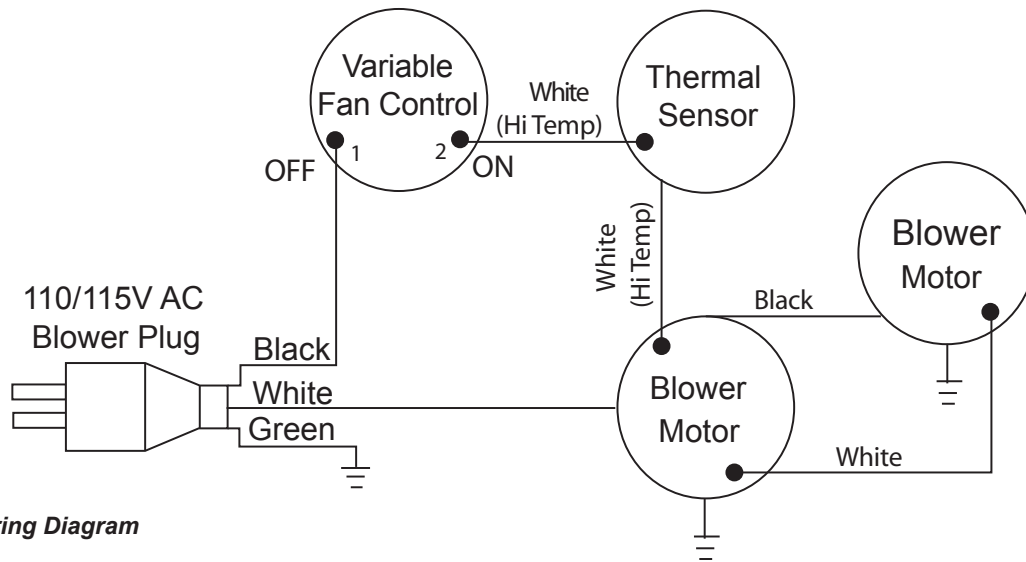


Figure 55 -  
Blower Wiring Diagram

**WARNING**

Electrical Grounding Instructions: This appliance is equipped with a three-prong (grounding) plug for your protection against shock hazard and should be plugged directly into a properly grounded three prong receptacle.

**NOTE:** Some older units are not equipped with mounting brackets. Velcro and magnets are used to mount blowers to sidewall and floor.



**FOR YOUR SAFETY READ BEFORE LIGHTING****WARNING**

If you do not follow these instructions exactly, a fire or explosion may result causing property damage, personal injury or loss of life.

- A. This appliance is equipped with a pilot which must be lit with built-in piezo ignitor while following these instructions exactly.
- B. BEFORE OPERATING smell all around the appliance area for gas. Be sure to smell next to the floor because some gas is heavier than air and will settle on the floor.

**WHAT TO DO IF YOU SMELL GAS:**

- Turn off all gas to the appliance.
  - Open windows.
  - Do not attempt to light any appliance.
  - Do not touch any electric switch; do not use any phone in your building.
  - Immediately call your gas supplier from a neighbor's phone. Follow the gas supplier's instructions.
  - If you cannot reach your gas supplier, call the fire department.
- C. Use only your hand to push in, or turn the gas control knob. Never use tools. If the knob will not push in or turn by hand, don't try to repair it. Call a qualified service technician. Force or attempted repair may result in a fire or explosion.
  - D. Do not use this appliance if any part of it has been under water. Immediately call a qualified service technician to inspect the appliance and to replace any part of the control system and any gas control that has been under water.

**LIGHTING PILOT FOR THE FIRST TIME****INITIAL LIGHTING**

Purge air from the supply line as follows:

- Open main shutoff valve.
- Unscrew main pressure test point.
- Leave inlet test screw open until gas comes in.
- When gas is flowing, tighten inlet screw immediately.

**WARNING**

Never use an open flame to check for gas leak.

**LEAK TESTING**

1. Follow the pipe from the gas supply line connection to the gas valve. Check connection for leaks with soap and water mixture.
2. Next check for gas leaks at the burner with soap and water mixture.
3. Check the pilot for gas leaks with soap and water mixture.

## LIGHTING PILOT FOR THE FIRST TIME

### APPROVED LEAK TESTING METHOD

You may check for gas leaks with the following methods only:

- Soap and water solution
- An approved leak testing spray
- Electronic sniffer

**WARNING**

If using a soap and water solution to test for leaks, **DO NOT** spray solution onto control body.

**NOTE:** Remove any excessive pipe compound from the connections. Excessive pipe compound can set off electronic sniffers.

**DANGER**

Never check for gas leak with open flame!

Check for gas leaks in each of the following locations:


- Pipe from the gas supply line connection to the gas valve
- Burner connections
- Pilot
- Each joint or connection
- Field made joints / gas shutoff valve
- Factory made joints
- All joints on valve and control body

## LIGHTING PILOT

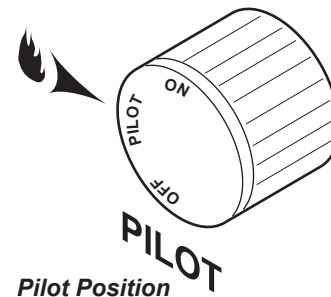
**WARNING**

The control has an interlock device that does not allow the lighting of the fireplace up to the moment the safety device of the flame has not interrupted the gas flow. After that period of time (when the magnet is closed), it is possible to start the lighting operation.

The gas control knob is designed to be operated by hand. **DO NOT** use any tools during this operation. Damaged knobs may result in serious injury.

1. Depress and turn knob counterclockwise  to pilot position.
2. Depress fully and hold pilot gas knob. Depress piezo igniter as many times as needed to ignite pilot. Keep knob fully depressed for a few seconds. Release and check that pilot continues to burn.

If the pilot does not stay lit, repeat steps 1 and 2.

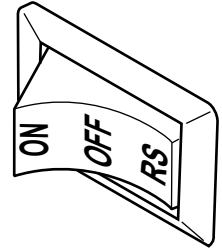


Continued on next page

## LIGHTING BURNER


### MAIN BURNER SWITCH

The "ON/OFF/RS" switch for the main burner can be found behind door of the fireplace. This switch allows you to turn on and to turn off the main burner without using the gas valve knob. Make sure the button is in the "ON" position to light the main burner.



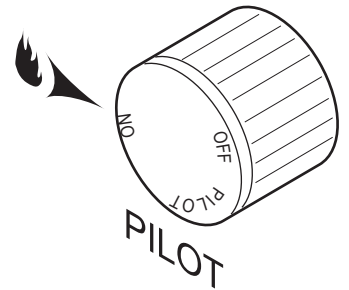
*On/Off/RS Switch*

### LIGHTING THE BURNER

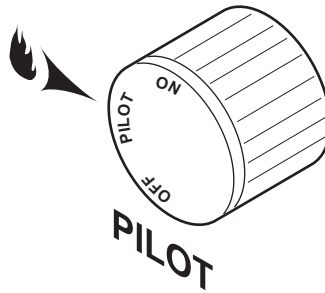
Depress and turn the knob counterclockwise  to the "ON" position. It will take less than four (4) seconds for the burner to ignite.

### PILOT POSITION

Depress and turn knob to pilot position to keep burner off while maintaining the pilot light.

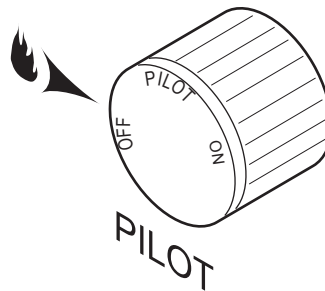


*On Position*



*Pilot Position*

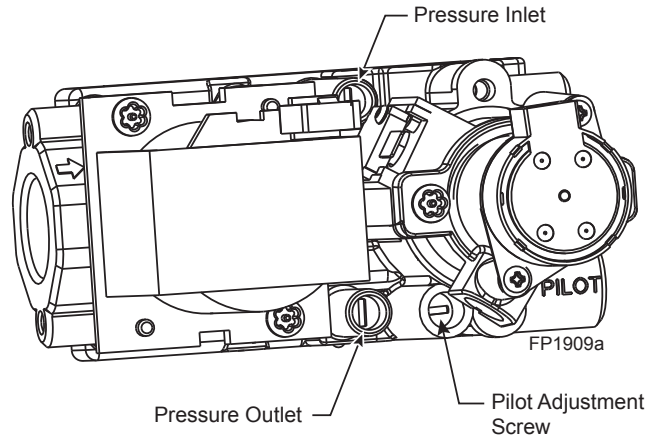
Depress and turn knob clockwise  to "OFF" position.



*Off Position*

## CHECK GAS PRESSURE and ELECTRICAL INSTALLATION - SIGNATURE COMMAND

1. Check gas type. The gas supply must be the same as stated on the appliance's rating decal. If the gas supply is different from the fireplace, **STOP!** Do not install the appliance. Contact your dealer immediately.
2. To ease installation, a 24" (610 mm) flex line with manual shut-off valve has been provided with on this appliance. Install and attach 1/2" gas line onto shut-off valve.
3. After completing gas line connection, purge air from gas line and test all gas joints from the gas meter to the fireplace for leaks. Use a solution of 50/50 water and soap solution or a gas sniffer.
4. To check gas pressures at valve, turn captured screw counter clockwise 2 or 3 turns and then place tubing to pressure gauge over test point. Turn unit to high. *Figure 56.* After taking pressure reading, be sure and turn captured screw clockwise firmly to reseal. Do not over torque. Check test points for gas leaks.



**Figure 56 -  
Signature Command Valve**

**WARNING**

**Do not use open flame to check for gas leaks.**

## ELECTRICAL WIRING

### General

1. This fireplace is equipped with the Signature Control valve which operates on 6 volts. The 6 volt DC adapter plugs into the fireplace junction box A/C power supply. Four (4) "AA" batteries are used for back up during power outages.
2. The Signature Command System can also be operated without A/C power. The system can run on four (4) "AA" batteries for approximately six (6) months under normal use.
3. A/C power must be used to power the A/C module, blowers, lights and AUX accessories if used with this fireplace.

### Optional Accessory Requirements

1. This fireplace may be used with a wall switch, wall mounted thermostat and/or Signature Command wireless controls.
2. The command center control may be mounted on the wall with the use of the SCSWEK 15ft. wall mount extension kit.

**WARNING**

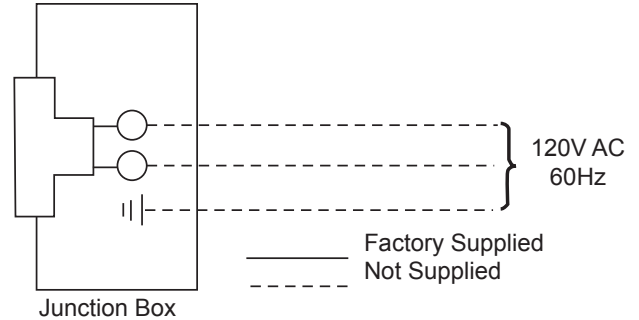
**Electrical connections should only be performed by a qualified, licensed electrician. Main power must be off when connecting to main electrical power supply or performing service. All wiring shall be in compliance with all local, city and state codes. The appliance, when installed, must be electrically grounded in accordance with local codes or in the absence of local codes, with the National Electrical Code ANSI/NFPA 70 (latest edition) and Canadian Electrical Code, CSA C22.1.**

**CAUTION**

**Label all wires before disconnecting when servicing controls. Wiring errors can cause improper and dangerous operation.**

## JUNCTION BOX WIRING

1. This should be done before framing the fireplace. Wire the receptacle into an electrical circuit. Wire with minimum 60° C wire in accordance with prevailing codes.
2. Remove the external junction box cover by removing the screw from the side of the outside firebox wall. Junction box was installed at the factory.
3. The junction box cover has a factory installed "romex" style strain relief connector. After connecting the wires, route the wire leads through this connector. Refer to the wiring diagram in *Figure 57*.



**Figure 57 -  
Junction Box Wiring Diagram**

## COMMAND CENTER WALL INSTALLATION

The command center may be mounted on the wall with the use of the SCSWEK Kit (15ft. cable, junction box, wall cover).

Mount the junction box provided at the desired location on the wall. Do not extend beyond the 15 ft. wire cable provided. If a longer distance is required, the 15 ft. may be extended up to 30 ft. maximum by using two (2) SCSWEK cables plugged together.

Route the wire from junction box to lower control area at bottom of fireplace. Unplug the 12" cable from the command center. Attach the connector to the pins from wire by pushing in to connector making sure to follow the color code on connector. Plug the 15 ft. extension cable into the 2 ft. cable. Remove command center from the fireplace and plug the other end of the extension cable into the command center. Snap on wall cover provided and screw to junction box.

## WALL SWITCH INSTALLATION

The wall switch wire connection is located off the 2 ft. wire harness from the control box to the command center. *Figure 58*. The connection is labeled "Wall Switch". Unplug the male and female connectors and connect the two (2) low voltage wires provided. Run wire to desired location on wall. Up to 50 ft. of 18 ga. wire may be used if necessary. Attach wires to wall switch. Mount the wall switch in to junction box and screw on cover.

**WARNING**

**Do not connect wall switch to 110 V circuit.**

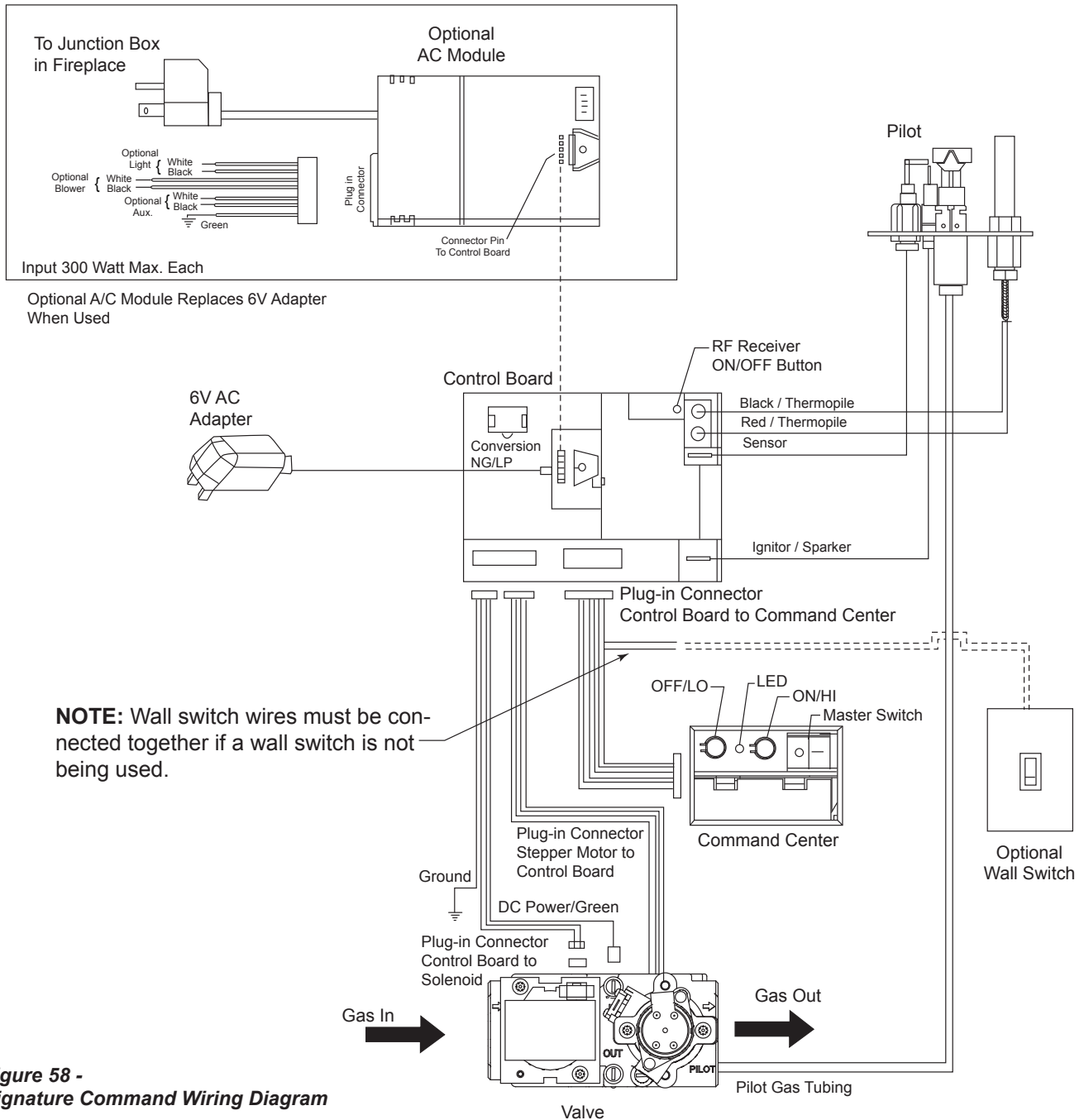


Figure 58 - Signature Command Wiring Diagram

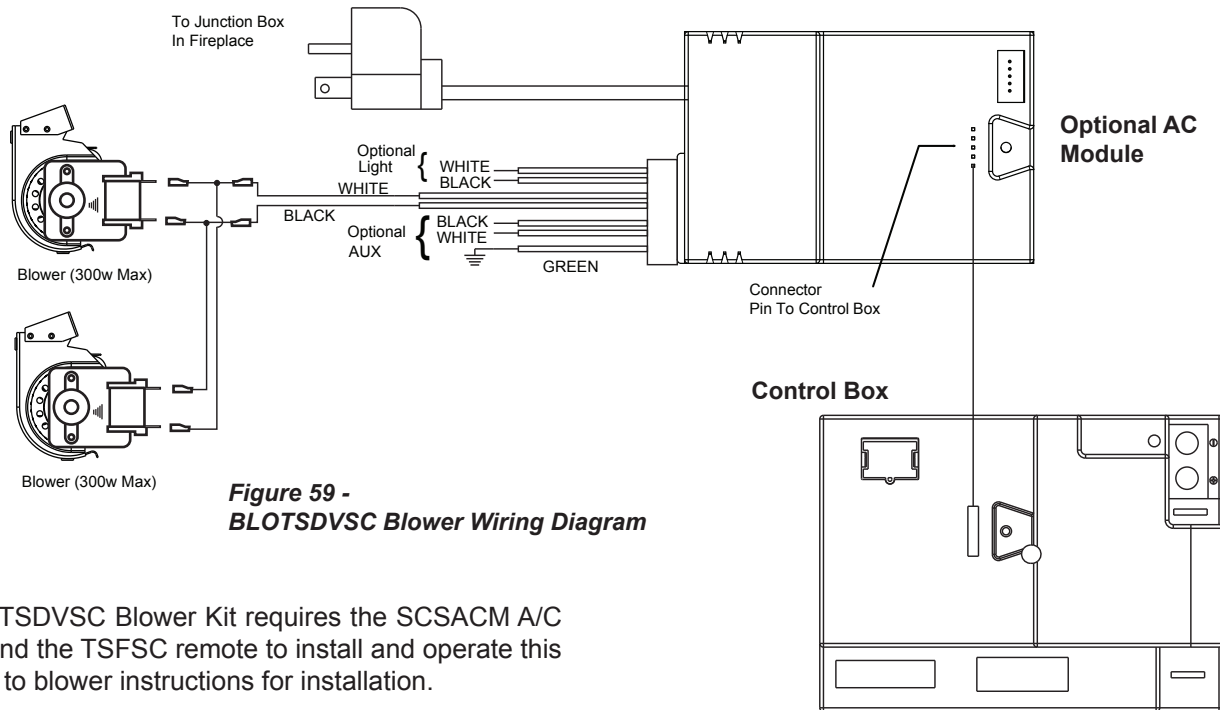
**CAUTION** Electrical connections should only be performed by a qualified, licensed electrician. Main power supply must be turned off before connecting fans to the main electrical power supply or performing service.

**WARNING** Electrical Grounding Instructions: This appliance is equipped with a three-prong (grounding) plug for your protection against shock hazard and should be plugged directly into a properly grounded three-prong receptacle.

**WARNING** Electrical connections should only be performed by a qualified licensed electrician. Main power supply must be turned off before connecting the fan to the main electrical power supply or performing service.

**NOTE** The black and white wires on the AC box wiring harness are marked 'Blower', 'Light' and 'Aux'. It is important to use the wires marked 'Blower' or the control will not work correctly.

**BLOTSDVSC SIGNATURE COMMAND BLOWER**

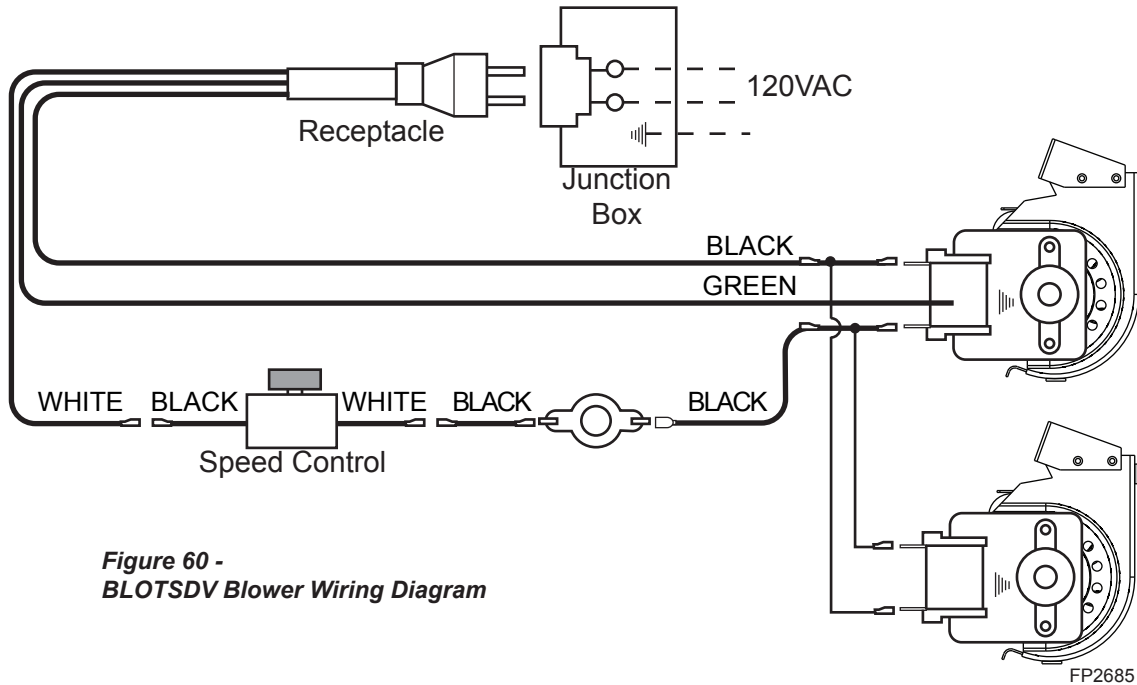


**Figure 59 - BLOTSDVSC Blower Wiring Diagram**

The BLOTSDVSC Blower Kit requires the SCSACM A/C Module and the TSFSC remote to install and operate this kit. Refer to blower instructions for installation.

FP2103

**BLOTSDV AUTOMATIC THERMOSTAT BLOWER**



**Figure 60 -  
BLOTSDV Blower Wiring Diagram**

Before installing the blower, wire the receptacle into an electrical circuit. This should be done before framing the fireplace. Wire with minimum 60° C wire in accordance with prevailing codes.



**FOR YOUR SAFETY READ BEFORE LIGHTING****WARNING**

If you do not follow these instructions exactly, a fire or explosion may result causing property damage, personal injury or loss of life.

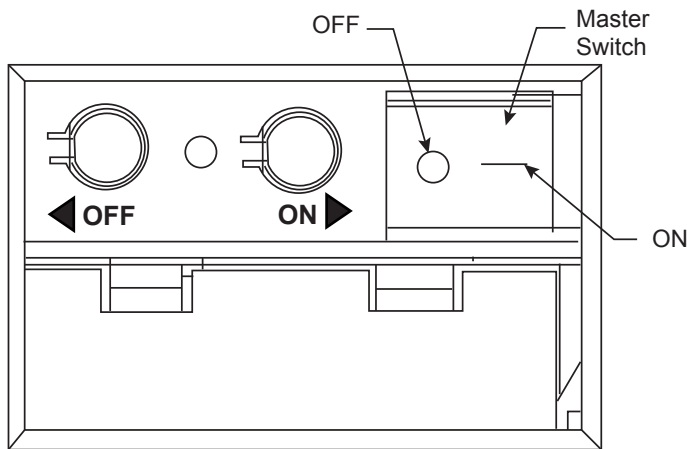
- A. This appliance is equipped with an ignition device which automatically lights the pilot. Refer to the instructions.
- B. BEFORE OPERATING smell all around the appliance area for gas. Be sure to smell next to the floor because some gas is heavier than air and will settle on the floor.

**WHAT TO DO IF YOU SMELL GAS:**

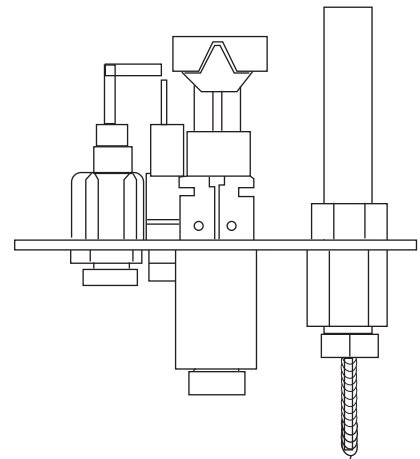
- Do not attempt to light any appliance.
  - Do not touch any electric switch; do not use any phone in your building.
  - Immediately call your gas supplier from a neighbor's phone. Follow the gas supplier's instructions.
  - If you cannot reach your gas supplier, call the fire department.
- C. Use only your finger to push in the master switch. Never use tools. If the switch will not function by hand, do not try to repair it. Call a qualified service technician. Force or attempted repair may result in a fire or explosion.
  - D. Do not use this appliance if any part of it has been under water. Immediately call a qualified service technician to inspect the appliance and to replace any part of the control system and any gas control that has been under water.

## OPERATING INSTRUCTIONS

1. **STOP!** Read the safety information above.
2. This appliance is equipped with an ignition device which automatically lights the burner. Do not try to light the burner by hand.
3. With five (5) minutes to clear out any gas. Then smell for gas, including near the floor. If you smell gas, **STOP!** Follow "B" in the safety information on page 38. If you do not smell gas, go to next step.
4. Press the master switch to the "ON" (-) position. Within eight (8) seconds it will beep once. This indicates the system is ready.
5. Press "ON " button. Sparker will spark and pilot flame will light.
6. Once pilot flame is established, the main burner flame will light automatically.
7. If the pilot will not stay lit after several tries, turn the master switch to "OFF" and call your service technician or gas supplier.



**Command Center**



## TO TURN OFF GAS TO APPLIANCE

1. Turn master switch to "OFF".
2. Turn off all electrical power to the appliance if service is to be performed.

**FEATURES**

**Command Center**

- Easy Access Function Operation and System Configuration
- Operation Confirmation/Fault Diagnostic Indications (LED/Buzzer)
- ON/OFF/HI/Med/Low Operation
- Optional Wall Mounting

**Control Board**

- Electronic Ignition
- Pilot Lockout safety feature
- Electric Power Regeneration from Thermopile to save battery
- 6-hour Automatic Shut Down Option
- Convenient NG/LP Gas Type Conversion
- Standing Pilot/Intermittent pilot Conversion
- Previous settings Restoration Ability (Memory Off)
- Uninterrupted Operation During Power Outage (Automatic Battery Backup)
- ON/OFF RF Remote Receiver
- Optional Transmitter Learn Capability

**AC Module Board (Optional, requires TSFSC Remote)**

- Easy Snap-on Design
- Embedded Compact 120 VAC Adapter with Auto Battery Back up Feature
- Remote Controlled 3-step Blower, Lighting, and On/Off Auxiliary AC Outputs

**Transmitter (Optional)**

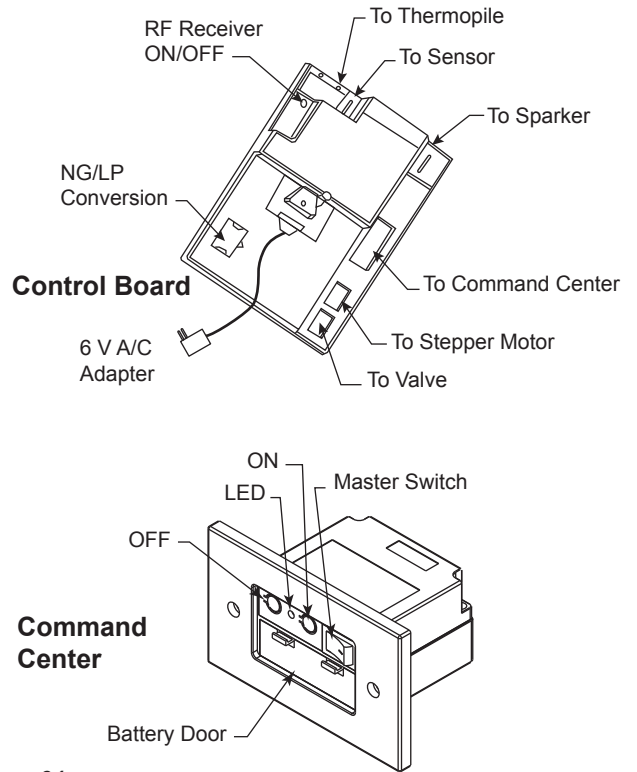
	TSFSC	TSTSC	TSMSC	RTSC	RMSC
Three Flame Height Settings	X	X	X	X	X
Low battery Indication for Transmitter	X	X	X	X	X
Child Proof Lock-out	X	X	X	X	X
LCD Backlight	X	X	X	X	X
Security Codes 16	X	X	X	X	X
Countdown 6 hr Timer	X	X	X	--	--
Standard Thermostatic Control Mode	X	X	--	X	--
Smart Mode® Thermostat (Auto Flame & Blower Modulation)	X	X	--	--	--
Three Brightness Settings for Lights	X	--	--	--	--
Three Speed Control for Blower	X	--	--	--	--
On/Off Auxiliary	X	--	--	--	--
Programmable Timer to turn blower on and off	X	--	--	--	--

**BATTERY INSTALLATION**

The Command Center uses four (4) "AA" batteries as back up for power outages. The system can operate for approximately six (6) months on battery power.

**To Install Batteries (not included):**

1. Press down the battery door tabs and pull out to remove battery door.
2. Install the batteries as indicated on Command Center.
3. Close battery door by snapping in place.
4. When the four (4) batteries are installed the system will operate without power.
5. The batteries should be replaced when the LED indicates low battery or at least once a year.



**Figure 61 - Signature Command System Components**

**SYSTEM CONFIGURATION/SETUP**

All System configuration/setup is done on the Command Center.

**NOTE:** When using On/Off wall switch, the switch must be in the ON position to perform all configuration set ups at the command center.

**Intermittent/Standing Pilot Setup (Default intermittent)**

1. Holding the ON button on the Command Center while turning on the master switch will toggle between standing pilot and intermittent pilot.
2. After the above operation, one beep (for standing pilot) or two beeps (for intermittent pilot) will be given as confirmation.

**Six-hour Safety Shutdown Option (Default ON)**

1. The system comes preset from the factory with a six (6) hour shutdown from its last command of operation. This is done to prevent the fireplace from continuing to operate if unattended. You may disable this feature if you wish.

**NOTE:** By disabling this feature, your fireplace may continue to operate unattended.

2. When the master switch is in the ON position (“-”), pressing the ON button and the OFF button on the Command Center simultaneously will toggle between enabling and disabling the six-hour shutdown option.
3. After the above operation, one beep (for enabling the six-hour shutdown option) or two beeps (for disabling the six-hour shutdown option) will be given as confirmation.

**Remote Transmitter Learn Function (Default OFF)**

1. The RF receiver button located on the Control Board must be in the on position before the learn function can begin. Use paper clip to depress button. One beep for RF receiver ON or two beeps for RF receiver OFF will be given as confirmation. Refer to Figure 62 for location.
2. After the RF receiver is on, holding the OFF button on the Command Center while turning on the master switch will activate the learn function for the transmitter.
3. After the above operation, two beeps will be given and the green LED on the Command Center will flash for 10 seconds.
4. During the 10 seconds, press the OFF button on a transmitter to learn. Another two beeps will be given to confirm a successful learning. Refer to transmitter instructions for remote operations.

**Shutting Off the Standing Pilot (Temporary Shut Off)**

To shut off the standing pilot for service or summer shut down, press and hold the ON button on the Command Center for 3 seconds when the master switch is in the ON position (“-”) and the main burner is off.

**Note:** Pilot will resume the next time system is turned on.

**Key Combinations for System Settings**

**NOTE:** When On/Off wall switch is used, it must be in the On position to perform all system setups.

Function	Operation	Default Setting
Intermittent/Standing Pilot Setup	Hold the ON ▲ button while turning on the master switch (Beep once for standing pilot, twice for intermittent pilot)	Intermittent Pilot
Standing Pilot Temp. Shutoff	Hold the ON ▲ button 3 seconds (when the master switch on the main burner is off)	
RF Remote Receiver On/Off	Push the RF receiver On/Off button on the control board Beep once for ON and beep twice for OFF	RF OFF
Learn Remote Transmitter	Hold the OFF ▼ button while turning on the master switch (Beep twice then press any handheld remote button)	
6-hour safety shutdown setup	Press the ON ▲ button and OFF ▼ button simultaneously (Beep once for ON, twice for OFF)	ON

# SIGNATURE COMMAND SYSTEM OPERATION INSTRUCTIONS

## FUNCTIONS/OPERATION

### Turning on the fireplace

1. Turn on the master switch and wait for a beep.
2. Press the ON button on the Command Center or turn on wall switch. Pilot will light and burner will come on High setting or last memory setting (See Turning Off Fireplace below). For memory feature.

### Pilot Safety Lockout Function

1. If the pilot doesn't light after sparking for 30 seconds, pilot trial lockout happens. The LED on the Command Center flashes Green once every 2 seconds, until reset.
2. If the pilot flame is lost during normal operation, the system will try three (3) times to relight after three (3) failures, flame loss lockout happens. The LED on the Command Center flashes Red-Green once every 2 seconds, until reset.
3. Turning the master switch on the Command Center to the off position, then ON again will reset the system.

### Flame Height Control

1. Press the ON button (on the Command Center) once to turn on the main burner with maximum flame height.

2. Press the OFF button to decrease flame height. The first two presses will decrease the flame height to medium and low.
3. The third press on OFF will turn off the main burner. In standing pilot configuration, the pilot will stay; in intermittent pilot configuration, the pilot will be shut off.

### Turning the Fireplace Off

There are three ways to turn the fireplace off.

1. Flip the master switch to the off ("O") position. (This will turn the entire system OFF.)
2. Press the OFF button to Medium, Low, then Off.
3. Hold the OFF button anytime for three seconds or by turning off the wall switch. These two commands of OFF are (Memory Off) the system will remember all last settings before turning off. The next time the fireplace is turned on, all settings will resume. To reset, change to the desired settings and shut off by using the Memory Off commands and the system will be reset to those new settings.

### Command Center Operations:

The following functions are available on the Command Center.

Function	Operation
Power Up	Flip the master switch to the ON ("I") position to power up the system
Fireplace ON	Press the ON ▲ button on the Command Center or turn on wall switch to turn the fireplace on
Fireplace OFF	Flip the master switch to the OFF ("O") position OR press the OFF ▼ button 3 times OR for Memory Off, hold the OFF ▼ button 3 seconds, or turn off wall switch
Flame Height Up	Press the ON ▲ button once to turn on the fireplace with maximum flame height
Flame Height Down	Press the OFF ▼ button to lower the flame height to Medium and Low

### Self Diagnostics Chart:

The Command Center has a self-diagnostic LED enabling you to troubleshoot problems and potentially avoid a service call. Please refer to the charts below for indicator reference.

Fault	LED Indication
Conversion Cover Missing	One RED (1 time)
Spark Fail	Two RED (1 time)
No Sensor Signal	Three RED (1 time)
Pilot Lockout - trial	One GREEN, every 2 sec. (until manual reset)
Pilot Lockout - flame loss	One RED-GREEN, every 2 sec. (until manual reset)
Low Battery	One RED, every 10s (continuously)
No or Low Thermopile Power	Two RED, every 10s (continuously)
Learning	GREEN Flashes, every 1 sec. (for 10 sec.)
AC Power On	GREEN solid
Pressure Switch Failure Power Vent Only	One RED every 2 sec. (until manual reset)

**GLASS FRAME REMOVAL**

1. Remove access panel by lifting up and out.
2. Release three (3) clamps on bottom of fireplace.  
*Figure 62*
3. Tilt glass frame out and lift glass frame up until it clears hook on top of fireplace.
4. Set glass frame aside.

**CAUTION** Each clamp has a quick spring force. When reinstalling clamps, keep fingers clear.

**WARNING**



HOT GLASS WILL CAUSE BURNS.  
DO NOT TOUCH GLASS UNTIL COOLED.  
NEVER ALLOW CHILDREN TO TOUCH GLASS.

**NOTE:** A mesh glass cover is available for this fireplace. This cover is recommended to reduce the severity of burns in case of accidental contact. Refer to the Accessories list on Page 57.

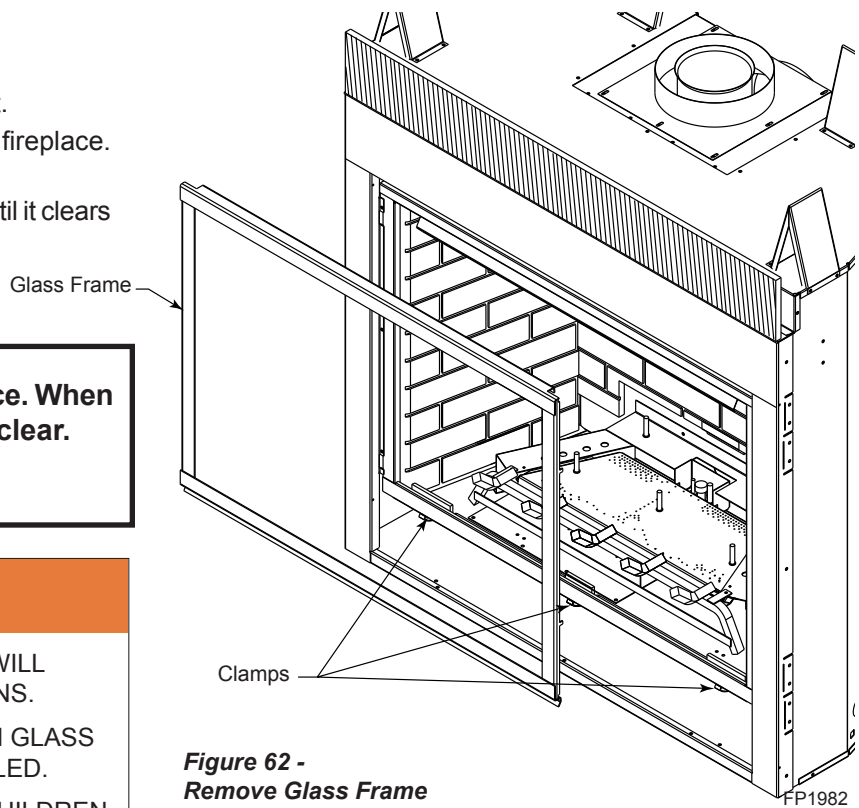
**BRICK INSTALLATION**

1. Install the rear brick panel by sliding it over the bracket fastened to the rear of the firebox.
2. Remove the existing screws fastened to the sides of the firebox toward the tops.
3. Slide the right panel into place and secure the panel using one of the brackets provided with the kit and one of the screws removed earlier.
4. Repeat step 2 for the left panel.

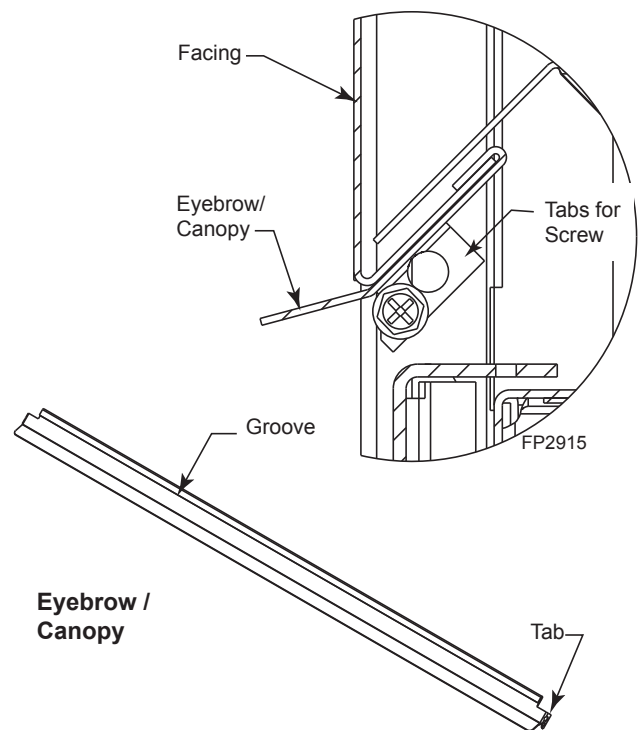
**EYEBROW/CANOPY INSTALLATION**

1. Remove glass frame.
2. Hold eyebrow/canopy with groove facing up and tabs for screws facing down. *Figure 63*
3. Install by placing eyebrow under bottom lip of facing. Hook bottom lip of facing into groove of eyebrow. Pull eyebrow forward until it stops. *Figure 63*
4. Insert self-tapping screws into tabs on bottom of eyebrow and into sides of facing.

**NOTE:** Eyebrow/canopy is optional depending upon clearances to combustible mantels and trim. Refer to Page 8.

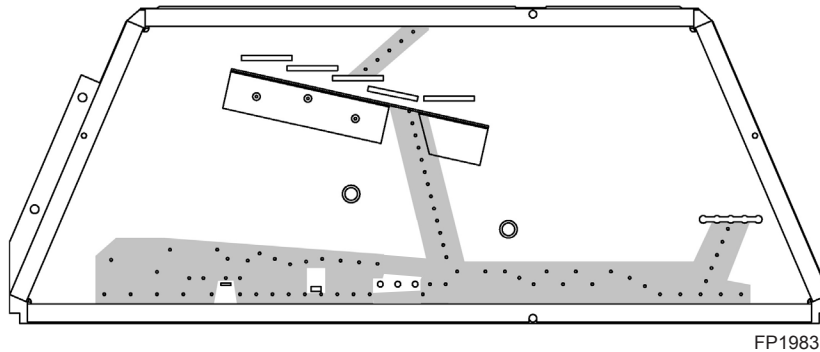


**Figure 62 - Remove Glass Frame**



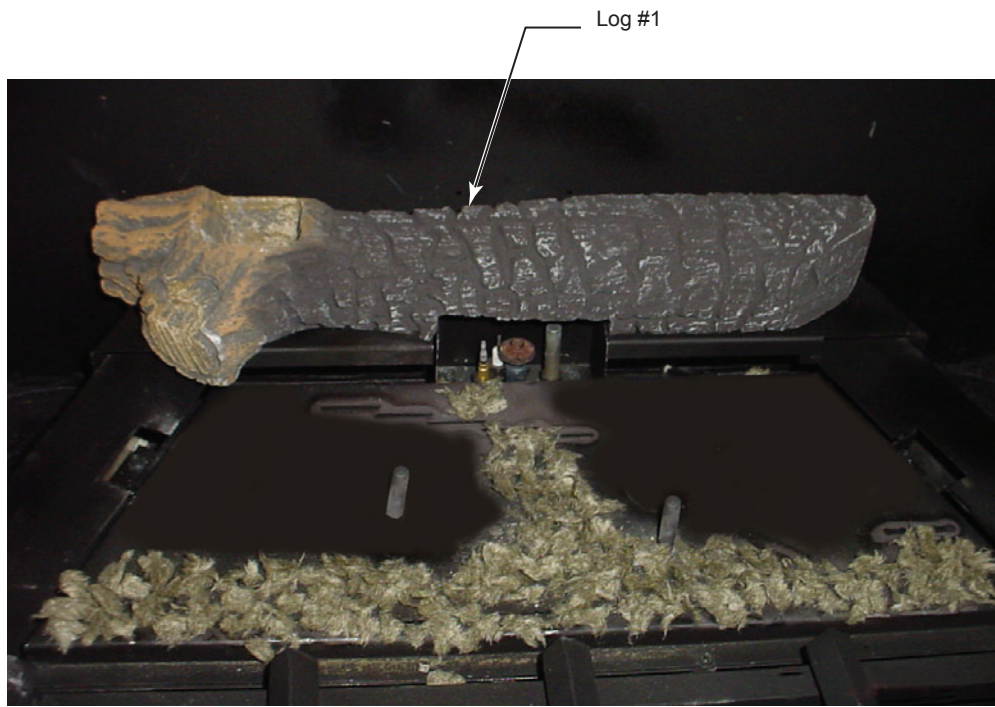
**Figure 63**

1. Distribute one layer of rock wool to cover all round burner ports. Do not cover rectangular slots, located in front and rear. *Figure 64*



**Figure 64 -  
Rock Wool Placement on Burner.**

2. Place log #1 by setting the log over the rear bracket over the two pins. *Figure 65*



**Figure 65 -  
Install log #1**

**NOTE:** Placing rock wool on burner provides glowing embers. For best results, pull the rock wool apart into pieces the size of a dime or smaller.

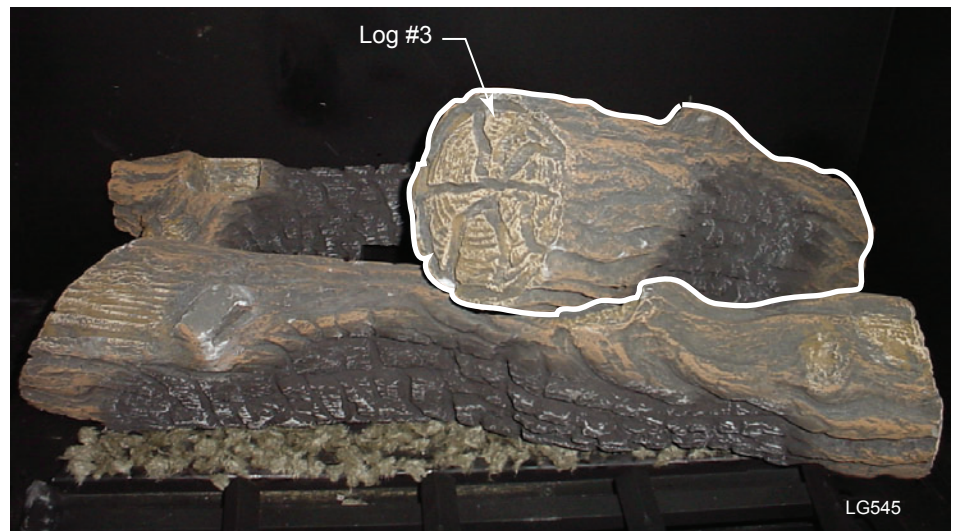
**WARNING** Do not use the entire bag of rock wool to cover the burner. This could cause the flame to burn poorly and may lead to sooting.



3. Place log #2 at angle across the burner by setting the logs over the two pins located on top of the burner. *Figure 66*

**Figure 66 -  
Install Log #2**

4. Place log #3 at an angle over log #2 toward the back by matching the rectangular notch on the bottom of this log with the rectangular protrusion on log #2. Then set the notch located on the bottom of this log toward the back over the metal bracket located to the right side of the burner. *Figure 67*



**Figure 67 -  
Install log #3**



5. Place log #4 by matching the rectangular protrusion on the bottom of this log over the rectangular notch on log #1, then swing the log slightly toward the front and set the log over the notch located on the upper surface of log #3. *Figure 68*

**Figure 68 -  
Install log #4**



- 6. Place log #5 by matching the rectangular notch on the bottom of the log with the rectangular protrusion on log #2, then set the notch on the bottom of this log over the very far left tong on the grate. *Figure 69*

Log #5



**Figure 69 -  
Install Log #5**

LG547



Log #6

- 7. Place log #6 at an angle over log #5 toward the back by matching the rectangular notch on the bottom of this log with the rectangular protrusion on log #5. Then, set the notch located on the bottom of this log toward the back over the metal bracket located to the left side of the burner. *Figure 70*

**Figure 70 -  
Install Log #6**

LG548

- 8. Place log #7 between the second and third right tong on the grate as shown in *Figure 71*.

**Figure 71 -  
Install log #7**



LG549

Log #7

**WARNING**

Turn off gas before servicing fireplace. It is recommended that a qualified service technician perform these check-ups at the beginning of each heating season.

## BURNER, PILOT AND CONTROL COMPARTMENT

Keep the control compartment, logs, and burner areas surrounding the logs clean by vacuuming or brushing at least twice a year. Make sure the burner porting, pilot air opening and burner air opening are free of obstructions at all times.

## PILOT FLAME

The flames from the pilot should be visually checked as soon as the heater is installed and periodically during normal operation. **The pilot flame must always be present when the fireplace is in operation.** Figure 72. The pilot flame has three distinct flames, one engulfing the thermopile, one engulfing the thermocouple or sensor, and the other reaching to the main burner.

## BURNER

Inspect area around the injector. Remove any lint or foreign material with a brush or vacuum.

## BURNER FLAME

The flames from the burner should be visually checked as soon as the heater is installed and periodically during normal operation. In normal operation, at full rate, and after operating for about 15 to 30 minutes, the flame should be yellow and slightly taller than the rear log. Figure 73

If the flame is blue and only in the center, turn off unit and let cool. After unit is cool, remove logs and check to make sure the back holes in the burner are not covered with rock wool. Replace logs.

**NOTE:** The type of installation, vent system configuration, and wind effects may cause the flame patterns to vary.

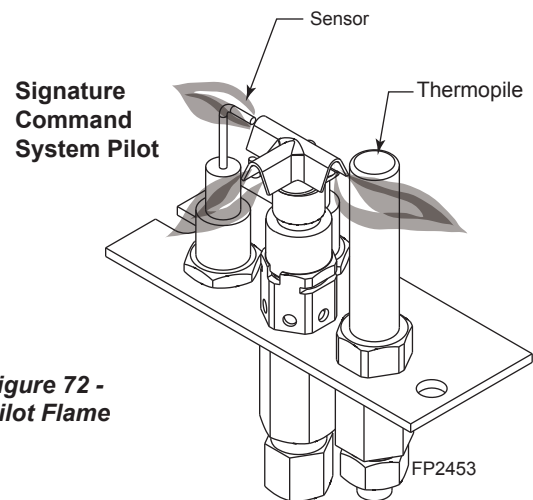
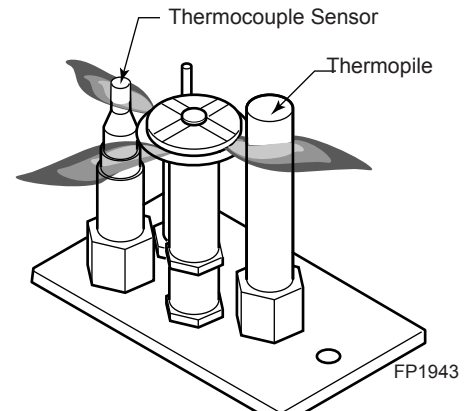


Figure 72 -  
Pilot Flame

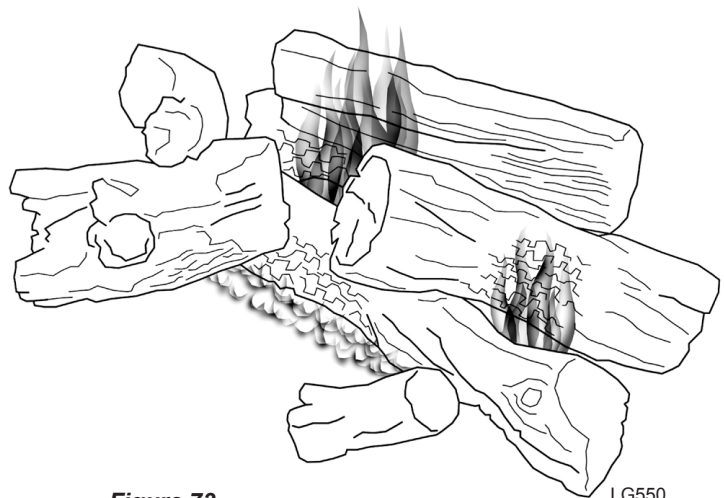


Figure 73 -  
Burner Flame Appearance

## VENTING SYSTEM

The fireplace and venting system should be inspected before initial use and at least annually by a qualified field service person. Inspect the external vent cap on a regular basis to make sure that no debris is interfering with the airflow. Inspect entire venting system to ensure proper function.

## GLASS DOOR

Thoroughly clean the inside of the glass door after using the fireplace for ten hours. Periodically clean the glass door as necessary.

When cleaning the glass, remember:

- **Do not remove the glass when hot.** Allow glass to cool before removal.
- NEVER use abrasive materials.
- Keep children and pets a safe distance away.
- Never operate the fireplace without the glass door properly secured.
- Never operate the fireplace if the glass is broken.
- Replace any glass that is chipped, cracked, or broken. Replacement glass door assemblies **MUST** be supplied by the fireplace manufacturer – **No substitute materials may be used.**
- Handle glass door with care to avoid striking or scratching it on hard objects.

To clean glass door, follow “Glass Removal” procedure outlined in the *Final Installation* section. Film deposit on the inside of the glass should be cleaned off using a nontoxic, non-corrosive, non-abrasive, mild-cleaning solution. Simply apply an adequate amount to the glass and wipe off with a damp cloth. After all maintenance has been completed, re-install glass door.

## LOGS

Leave logs installed in the fireplace for cleaning. Vacuum surface of the logs with a brush attachment. If logs must be removed for cleaning, handle carefully by holding gently at each end. Gloves are recommended to prevent skin irritation from ceramic fibers. If skin becomes irritated, wash gently with soap and water. Vacuum surface of logs with brush attachment or brush logs with a soft bristle brush (i.e. clean, dry paintbrush). To place logs back in the fireplace, see “Log Placement” found in the *Final Installation* section.

**NOTE: Do not use fluids to clean ceramic fiber logs.**

## ROCK WOOL

Replace or add rock wool as required following installation instructions in the *Final Installation* section of this manual.

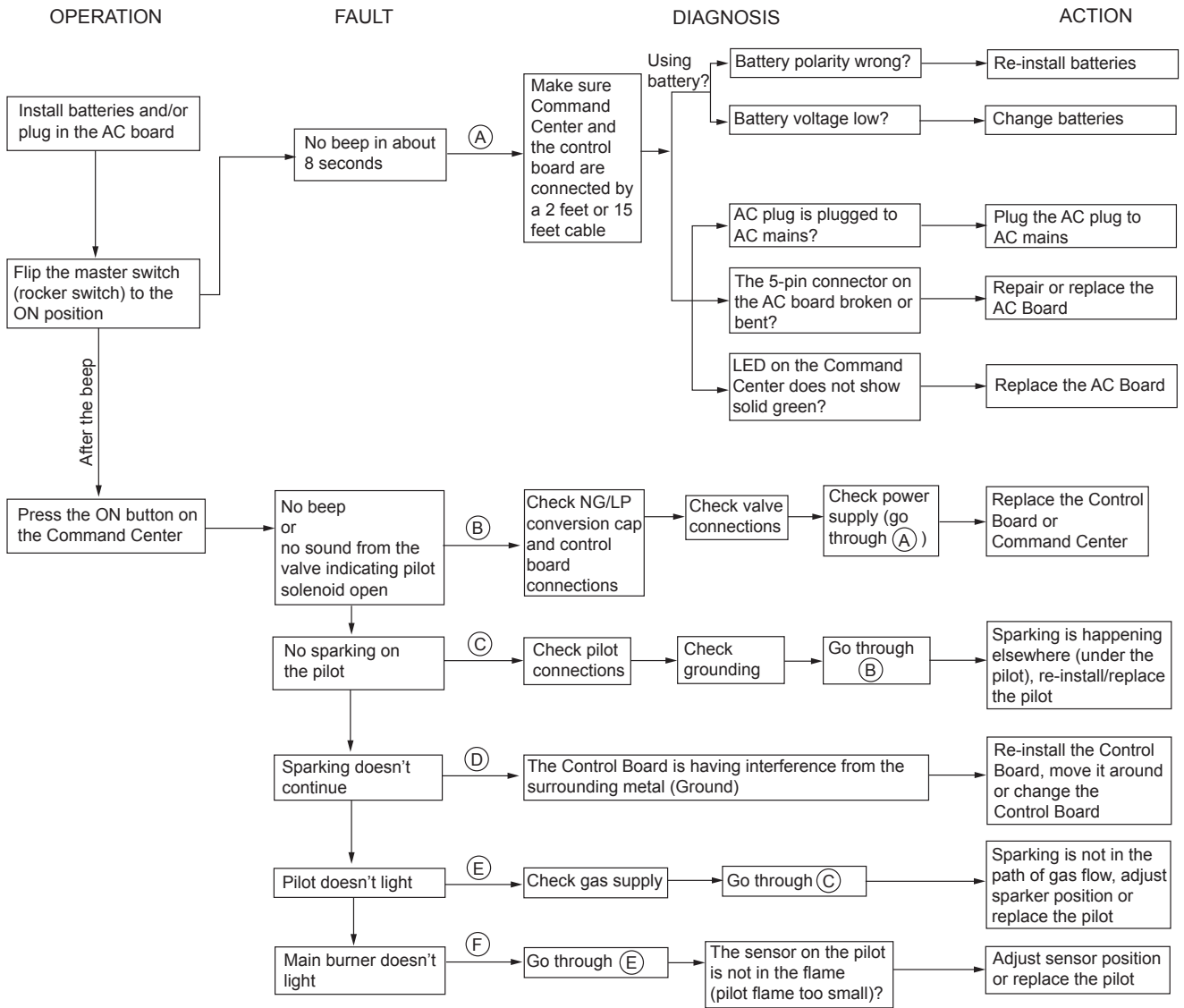
**STANDING PILOT IGNITION MILLIVOLT SYSTEM**

<b>SYMPTOM</b>	<b>POSSIBLE CAUSE</b>	<b>ACTION</b>
1. Spark ignitor will not light pilot after repeated triggering of piezo.	<p>A. Wire disconnected.</p> <p>B. Defective ignitor.</p> <p>C. No gas or low gas pressure.</p> <p>D. No Propane/LPG in tank</p>	<p>A. Open door and check to make sure wire is connected to ignitor.</p> <p>B. Check for spark at electrode and pilot. If no spark and electrode wire is properly connected, replace pilot assembly.</p> <p>C. Check remote/manual shut off valve from fireplace. Low pressure can be caused by bent lines, restricted lines, low pressure line pressure. Consult with plumber or gas supplier.</p> <p>D. Check Propane/LPG tank. Refill tank.</p>
2. Pilot will not stay lit after carefully following lighting instructions.	<p>A. Defective thermocouple</p> <p>B. Defective valve</p>	<p>A. Check that thermocouple flame impinges on thermocouple. Clean and/or adjust pilot for maximum flame impingement. Ensure that the thermocouple connection at the gas valve is fully inserted and tight. Disconnect the thermocouple from the valve, place one millivolt lead wire on the tip of the thermocouple and the other meter lead wire on the thermocouple copper lead. Start the pilot and hold the valve knob in. If the millivolt reading is less than 15 mV, replace pilot assembly.</p> <p>B. If thermocouple is producing more than 15 mV, replace faulty valve.</p>
3. Pilot burning, valve knob turned to "ON", switch is turned to "ON" or "RS", but burner will not ignite.	<p>A. Defective switch, wall switch, remote control or wire</p> <p>B. Pilot flame too small</p> <p>C. Defective or malfunctioning thermopile</p> <p>D. Defective valve</p>	<p>A. Check switch and wire for proper connection. Place jumper wires across terminals of switch. If burner comes on, replace defective switch. If the switch is OK, repeat the same procedure on remote control. If burner comes on, replace remote control. Place jumper wire across wire at gas valves (terminals marked TH and TP/TH). If burner comes on, wires are faulty or connections are bad. Replace wire.</p> <p>B. If pilot flame is not close enough to the thermopile, adjust pilot flame.</p> <p>C. Check thermopile wire connections to make sure all are tight and that the thermopile is fully inserted into pilot assembly. Check thermopile with a millivolt meter. Connect leads to TP and TP/TH terminals on the control valve. If meter reading is below 325 mV, replace pilot assembly.</p> <p>D. Turn valve knob to "On" and switch to "ON." Take a reading at the thermopile leads (TP &amp; TP/TH) on the valve. If the meter reads greater than 175 mV and the burner does not light, replace defective valve.</p>

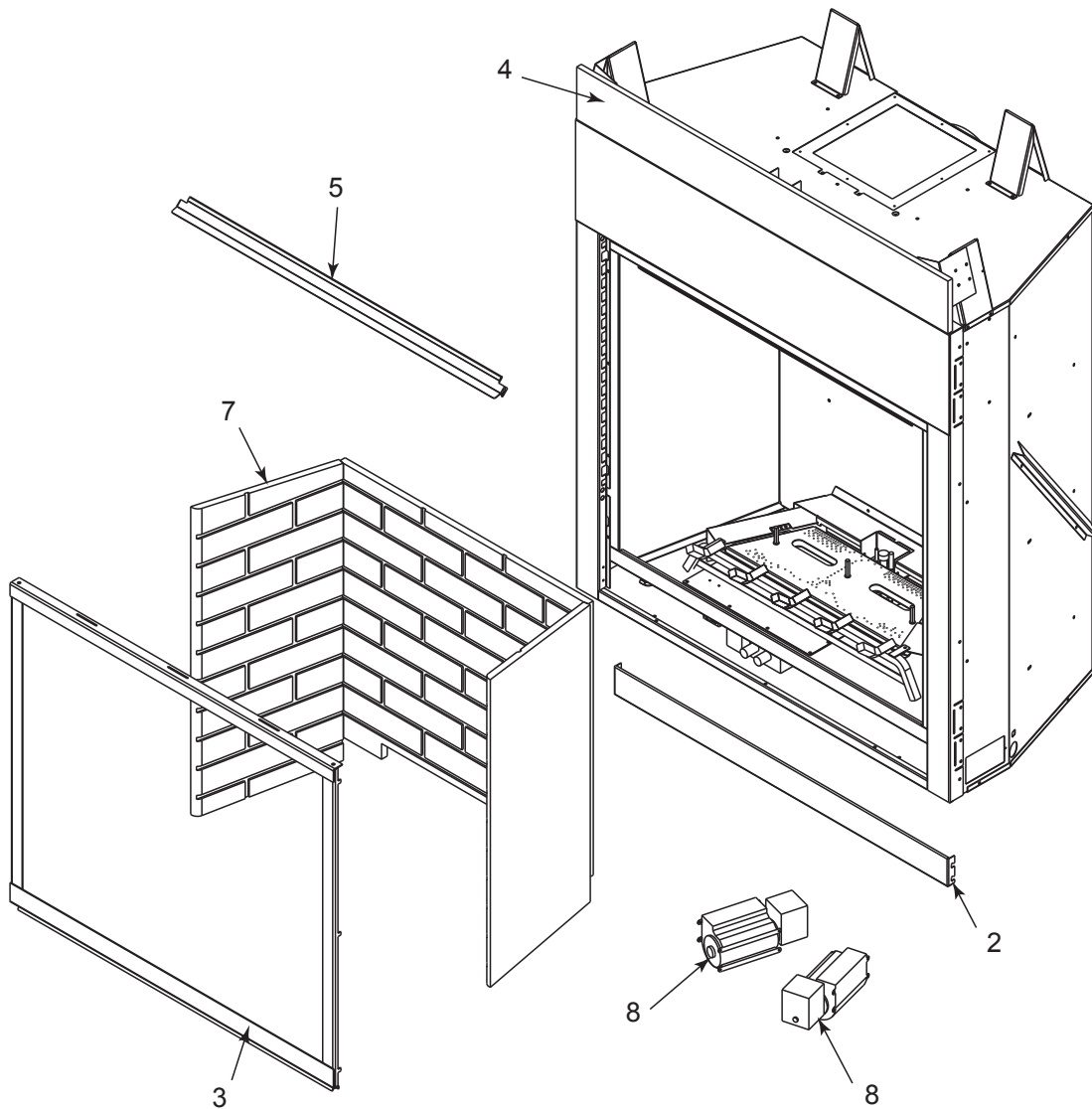
**STANDING PILOT IGNITION MILLIVOLT SYSTEM**

<b>SYMPTOM</b>	<b>POSSIBLE CAUSE</b>	<b>ACTION</b>
4. Frequent pilot outage problem.	A. Pilot flame may be too high or too low, causing pilot safety to drop out	A. Clean and adjust the pilot flame for maximum flame impingement on thermocouple.
5. The pilot and main burner extinguish while in operation	A. Inner vent pipe leaking exhaust gases back into system B. Horizontal vent improperly pitched C. Improper vent cap installation	A. Check for flue product leak. Replace defective pipe section. B. Check horizontal-venting piping is running upward 1/4" per foot. Do not run the pipe level or downward. C. Check for proper installation and freedom from debris or blockage.
6. Glass Soots	A. Flame impingement on logs	A. Install log set per the instructions Inspect the injector and air intake area. Make sure this area does not have any blockage from debris and clean. Check gas supply.
7. Flame burn blue and lifts off burner (ghosting)	A. Insufficient oxygen being supplied	A. Ensure that the vent cap is installed properly and free of debris. Ensure that the vent system joints are tight and have no leaks. Ensure that no debris has been blocking the inner air intake at the bottom back of the combustion chamber. Ensure that the glass is properly secure and latch.

SIGNATURE COMMAND SYSTEM

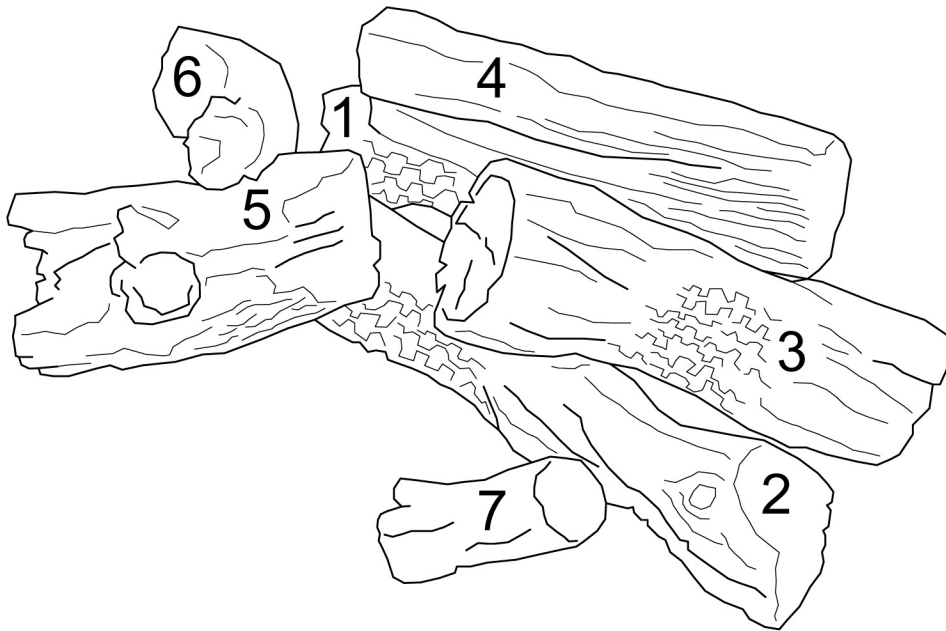


FIREBOX COMPONENTS and ACCESSORIES



Item	Description	Qty.	MLDV500
<b>Standard Features</b>			
1.	Junction Box Assembly (not shown)	1	26D2128K
2.	Control Cover	1	74D0119
3.	Glass Frame Assembly	1	75D1016
4.	Insulation Board	1	75D0008
5.	Eyebrow	1	20302777
<b>Accessories/Field Installed Options</b>			
6.	Decorative Mesh Glass Cover (not shown)	1	MLDV500SD
7.	Firebrick Walls - Cottage Clay	1	FBMLDV500CC
7.	Firebrick Walls - Cottage Red	1	FBMLDV500CR
7.	Firebrick Walls - Vintage Brown Herringbone (not shown)	1	FBMLDV500VB
8.	T-stat Blower w/Speed Control (not shown)	1	BLOTBLDV
8.	SCS Blower Kit w/Timer Delay	1	BLOTBLDVSC
9.	Andiron Kit (not shown)	1	FAI135

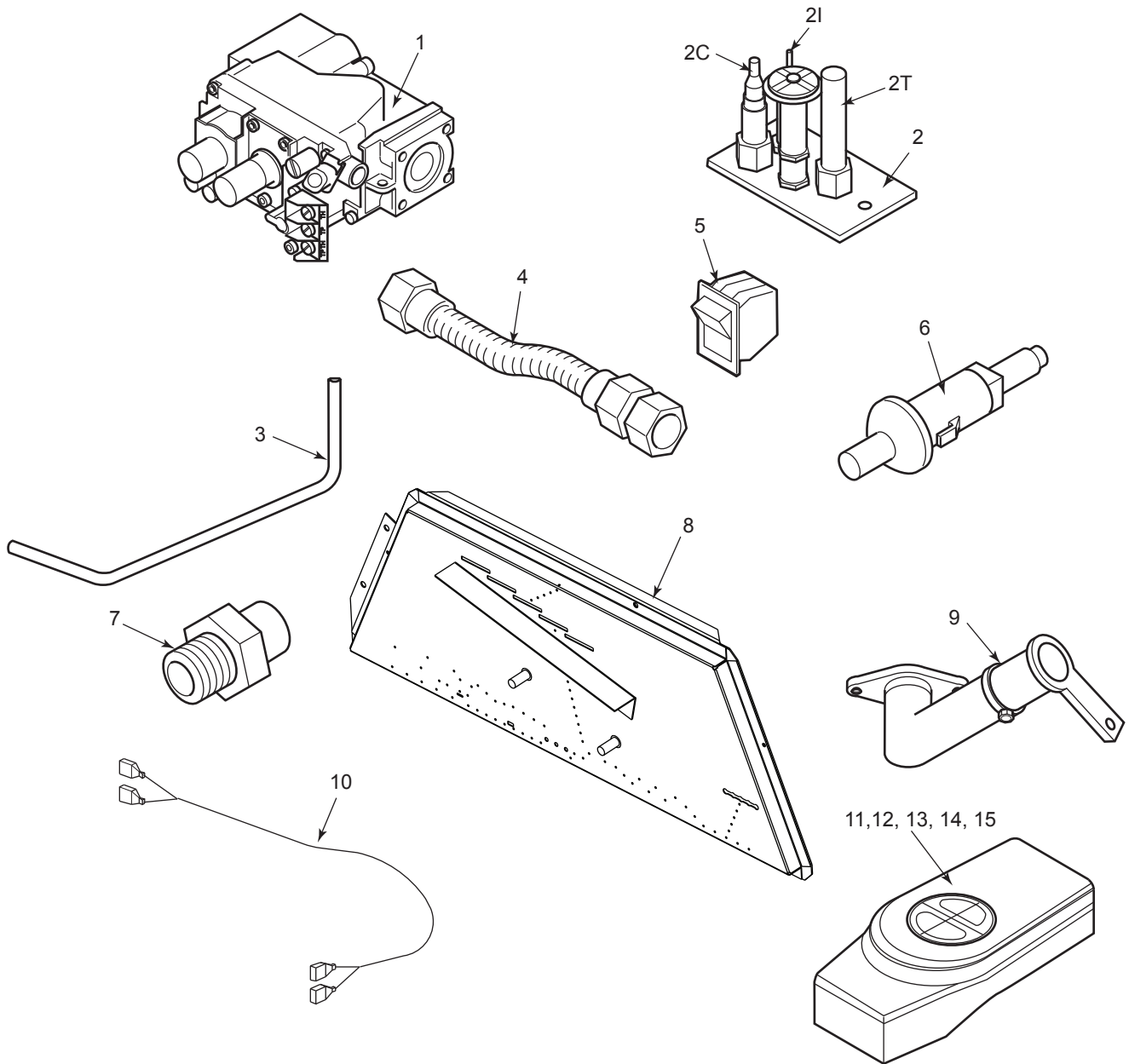
LOGS



Item	Description	Qty.	MLDV500
1.	Log #1	1	75D0536
2.	Log #2	1	75D0537
3.	Log #3	1	75D0538
4.	Log #4	1	75D0539
5.	Log #5	1	75D0540
6.	Log #6	1	75D0541
7.	Log #7	1	75D0542



STANDING PILOT - MILLIVOLT CONTROL



**STANDING PILOT – MILLIVOLT CONTROL**

Item	Description	Qty.	MLDV500NV	MLDV500PV
1.	Gas Valve Assembly	1	37D0117	37D0118
2.	Pilot Assembly	1	34D0018	37D0019
2C.	Replacement Thermocouple	1	37D1067	37D1067
2I.	Replacement Igniter and Wire	1	37D1069	37D1069
2T.	Replacement Thermopile	1	37D1068	37D1068
3.	Burner Tube	1	75D0550	75D0550
4.	Flex Hose w/Shutoff Valve	1	69D0030	69D0030
5.	Rocker Switch	1	41D0048	41D0048
6.	Piezo Igniter	1	14D0503	14D0503
7.	Injector	1	56D0613	20H3153
8.	Burner Assembly	1	75D1008	75D1008
9.	Venturi	1	45D0600	45D0600
10.	Wire Assembly	1	44D0500	44D0500
10.	Wire Assembly	1	44D0501	44D0501
<b>Accessories</b>				
11.	Thermostatic Remote Control	1	RCST/RCT/WWTD/RCSTEB/RCSITE	
12.	On/Off Remote Control	1	RCB/RCBE/RCMT/WMTD	
13.	Full Function Remote Control	1	RCSTEB/RCSITE	
14.	Wall Switch	1	MVWS	
15.	Wired Thermostat Kit	1	WT	

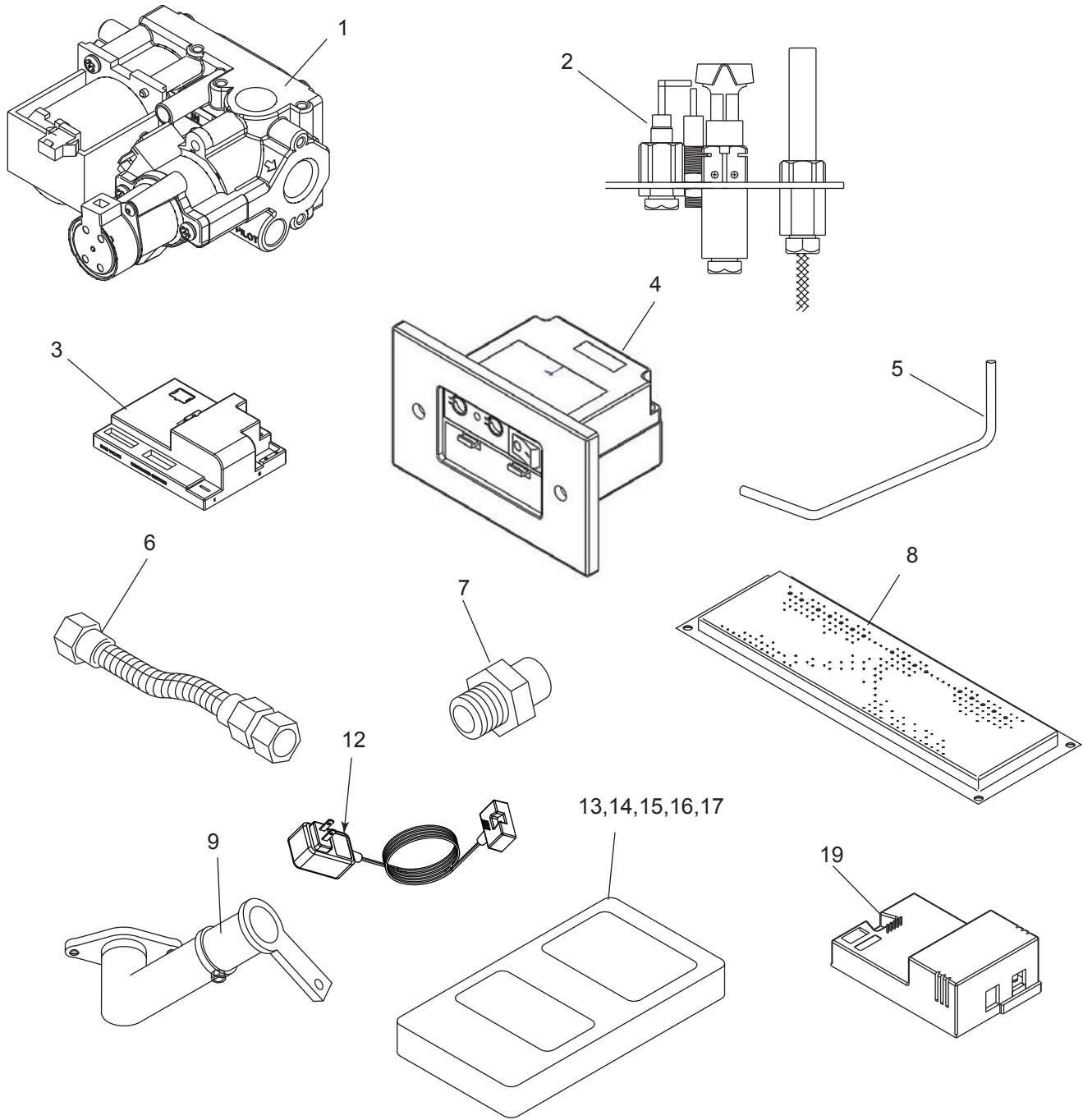
**Fuel Conversion Kits - Millivolt Control****Natural Gas to LP**

MLDV500 Kit #ML500CKP

**LP to Natural Gas**

MLDV500 Kit #ML500CKN

SIGNATURE COMMAND SYSTEM



**SIGNATURE COMMAND SYSTEM**

Ref.	Description	Qty.	MLDV500NS	MLDV500PS
1.	Gas Valve Assembly	1	80D0001	80D0002
2.	Pilot Assembly	1	80D0006	80D0007
3.	Control Box	1	80D0018	80D0019
4.	Command Center	1	80D0005	80D0005
5.	Burner Tube	1	75D0550	75D0550
6.	Flexhose with Shutoff Valve	1	69D0030	69D0030
7.	Injector	1	56D0613	20H3153
8.	Burner Assembly	1	75D1008	75D1008
9.	Venturi	1	45D0600	45D0600
10.	Wire Valve/Control (not shown)	1	80D0010	80D0010
11.	Wire Command Center Control Box 2 feet (not shown)	1	80D0008	80D0008
12.	A/C Adapter (6 Volt)	1	80D0041	80D0041
<b>Accessories</b>				
13.	Hand Held Remote Control w/ HI/LO and Timer			RMSC
14.	Hand Held Remote Control w/ Hi/lo And Tstat			RTSC
15.	Touch Screen Remote w/Optional Light, Auxiliary and Blower Control			TSFSC
16.	Touch Screen Remote Hi/Lo and Timer			TSMSC
17.	Touch Screen Remote Hi/Lo and TStat			TSTSC
18.	SCS Wall Mount Extension Kit (15' wire, rough-in box, wall cover) (not shown)			SCSWEK
19.	SCS AC Module (Opt. Blower, Light & Aux. Control)			SCSACM

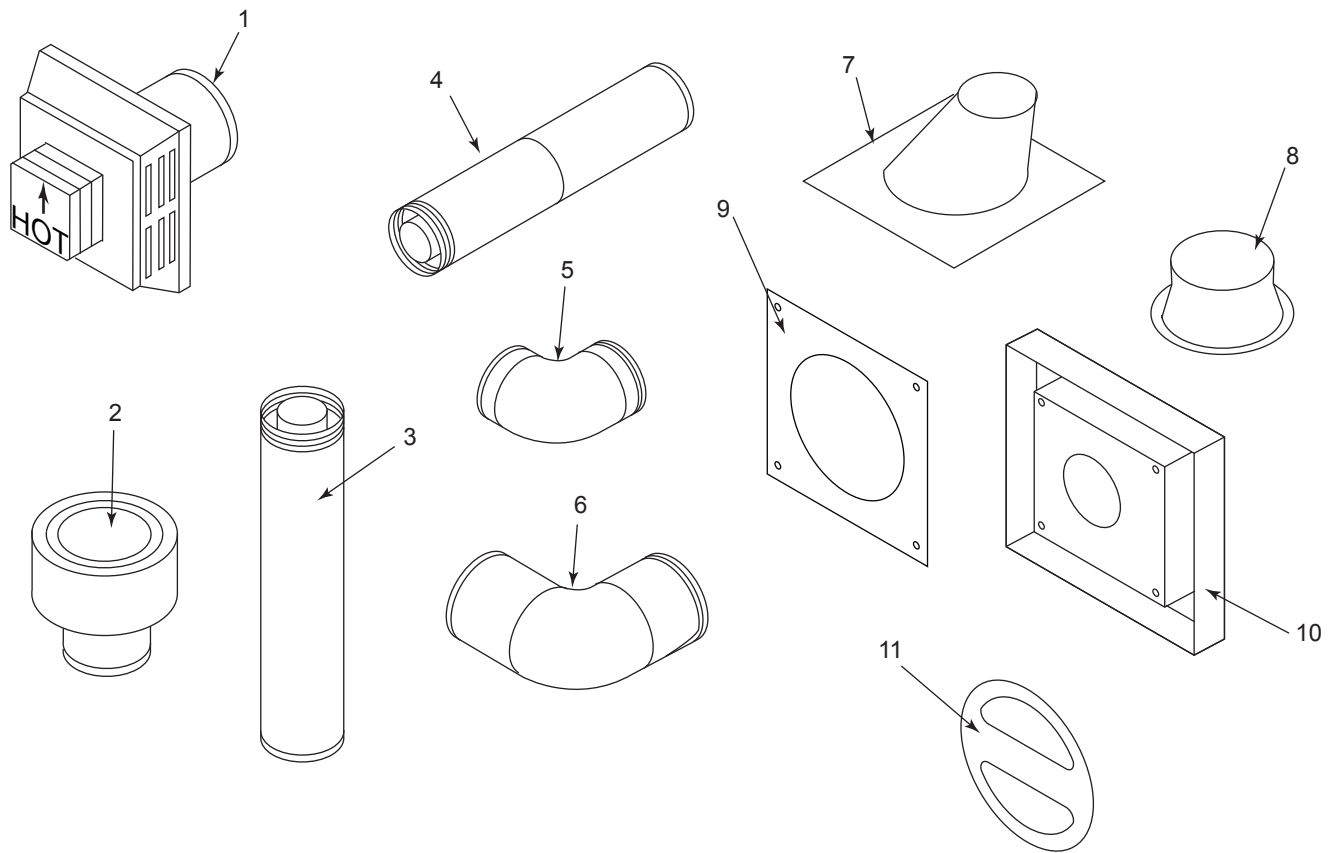
**NOTE:** TSFSC must be used with SCS A/C Module to control blower, lights and aux.

**Fuel Conversion Kits - Signature Command System****Natural Gas to LP**

MLDV500 Kit #ML500CKPS

**LP to Natural Gas**

MLDV500 Kit #ML500CKNS



For more information about, or instructions for, the venting components referenced above, please contact the component manufacturer:

Selkirk Corporation: [www.selkirkcorp.com](http://www.selkirkcorp.com) or 800-992-8368

Simpson Duravent: [www.duravent.com](http://www.duravent.com) or 800-835-4429

VENT COMPONENTS FOR 4" X 6<sup>5/8</sup>"

Item	Qty./ Box	Description	Current Simpson Duravent or MHSC Part no.	Old Simpson Duravent or MHSC Part no.	Selkirk Part no.
1	1	Thru-roof Flexible Pipe Termination Kit with flex adapter 24" rigid pipe, roof support 4" x 6 <sup>5/8</sup> " and termination cap	TRFK	--	--
1	1	Horizontal Square Termination Cap with built-in vinyl siding standoff, heat deflector and firestop	BHRTK	BHRTK	--
1	1	Square Horizontal Termination Cap	46DVA-HC	985	4DT-HC
1	1	Round Horizontal Termination Cap	46DVS-HRCS	--	--
1	1	Sconce Termination Cap (aluminum)	46DVA-HSC	--	--
2	1	Low-Profile Vertical Termination Cap	46DVA-VC	980	4DT-VC
3	6	6" Pipe Length (galvanized)	46DVA-06	908	4DT-06
3	6	9" Pipe Length (galvanized)	46DVA-09	907	4DT-09
3	6	12" Pipe Length (galvanized)	46DVA-12	906	4DT-1
3	6	24" Pipe Length (galvanized)	46DVA-24	904	4DT-4
3	6	36" Pipe Length (galvanized)	46DVA-36	903	4DT-36
3	6	48" Pipe Length (galvanized)	46DVA-48	902	4DT-48
4	6	8 <sup>1/2</sup> " Pipe Extension (galvanized)	46DVA-08A	--	4DT-AJ
4	6	16" Pipe Extension (galvanized)	46DVA-16A	--	4DT-AJ14
5	6	45° Elbow (galvanized)	46DVA-E45	945	4DT-EL45
6	6	90° Elbow (galvanized)	46DVA-E90	990	4DT-EL90
7	6	Adjustable Roof Flashing 0/12 - 6/12	46DVA-F6	943	4DT-AF6
8	6	Storm Collar	46DVA-SC	953	4DT-SC
9	6	1" Firestop	46DVA-FS	963	4DT-FS
9	6	3" Firestop	FS3	--	--
10	1	Vinyl Siding Standoff	46DVA-VSS	950	4DT-VS
11	1	Restrictor Disk	45D0551	45D0551	--
	1	Attic Insulation Shield	46DVA-IS	--	--
	6	Steep Roof Flashing 7/12 - 12/12	46DVA-F12	943S	--
	8	Horizontal Termination with 1" firestop	BHRT/8	--	--
	8	Flex Adapter Starter	DVFFA/8	--	--

**VENT COMPONENTS FOR 5" X 8"**

Item	Qty./ Box	Description	Current Simpson Duravent or MHSC Part no.	Old Simpson Duravent or MHSC Part no.	Selkirk Part no.	Metal-Fab Part no.
1	1	Horizontal Termination Cap w/Built-In Vinyl Siding Standoff Heat Deflector, Firestop and Adjustable Pipe 11" to 14 <sup>5</sup> / <sub>8</sub> "		BHR58TK9		--
1	1	Horizontal Termination Cap Built-In Vinyl Siding Standoff, Heat Deflector, Firestop, 90° Elbow and Adjustable Pipe 11" to 14 <sup>5</sup> / <sub>8</sub> "		BHS58TK		--
1	1	Horizontal Termination Cap w/Built-In Vinyl Siding Standoff, Heat Deflector, Firestop, Flexible Pipe 20" to 48", Adapter		BHSF58TK		--
1	8	Horizontal Termination w/ 1" Firestop		BHR58T/8		
1	1	Horizontal High Wind Termination Cap	58DVA-HC	1285	5DT-HC	--
1	1	Horizontal Temination Cap				5DHT
2	1	Vertical Termination	58DVA-VC	1280	5DT-VC	5DVT
3	4	6" Pipe Length	58DVA-06	1208	5DT-06	5D6
3	4	9" Pipe Length	58DVA-09	1207	5DT-09	
3	4	12" Pipe Length	58DVA-12	1206	5DT-12	5D12
3	4	24" Pipe Length	58DVA-24	1204	5DT-24	5D24
3	4	36" Pipe Length	58DVA-36	1203	5DT-36	5D36
3	4	48" Pipe Length	58DVA-48	1202	5DT-48	5D48
4	4	8 <sup>1</sup> / <sub>2</sub> " Pipe Extension	58DVA-08A	--	5DT-AJ	
4	4	16" Pipe Extension	58DVA-16A	--	--	
5	4	45° Elbow	58DVA-E45	1245	5DT-EL45	5D456
5	4	45° Swivel Elbow	--	--	5DT-EL45	
6	4	90° Elbow	58DVA-E90	1290	5DT-EL90S	5D906
6	4	90° Swivel Elbow	--	1290G	5DT-EL90S	
7	6	Flashing, 0/12 to 6/12 Roof Pitch	58DVA-F6	1243	5DT-AF6	5DF
7		Steep Roof Flashing	58DVA-F12	1243S	--	
8	6	Storm Collar	58DVA-SC	1253	5DT-SC	5DSC
9	4	Firestop	58DVA-FS	1263	5DT-FS	5DFS
9		3" Firestop	FS38	FS38	--	
10	1	Vinyl Siding Standoff	58DVA-VSS	1250	5DT-VS	5DVS
11		Attic Insulation Shield (not shown)	58DVA-IS	--	--	
12	8	Flex Adapter Starter (not shown)	DVFF8A/8	--	--	
13	1	Reducer - 5 x 8 to 4 x 6 <sup>5</sup> / <sub>8</sub> (not shown)	1222DA	1222DA	--	

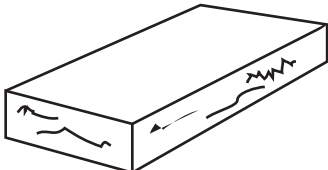
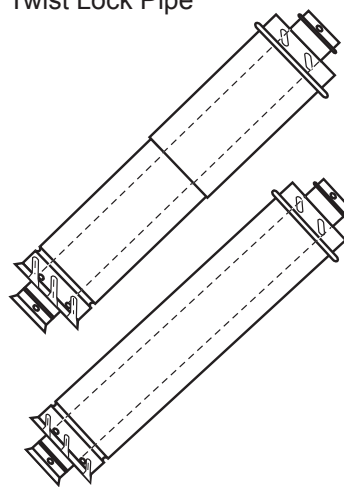

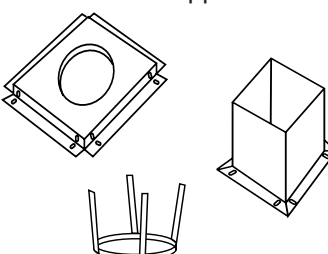
For more information about, or instructions for, the venting components referenced above, please contact the component manufacturer:

Selkirk Corporation: [www.selkirkcorp.com](http://www.selkirkcorp.com) or 800-992-8368

Simpson Duravent: [www.duravent.com](http://www.duravent.com) or 800-835-4429

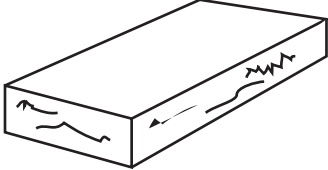
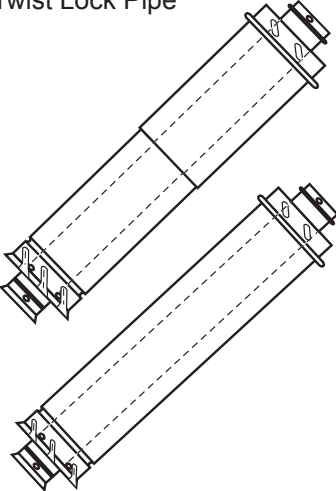
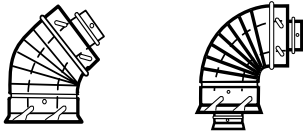
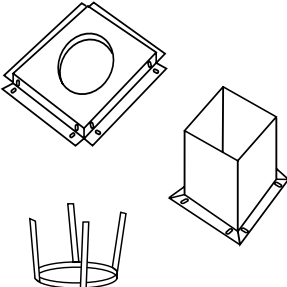
Metal-Fab, Inc.: [www.metal-fabinc.com](http://www.metal-fabinc.com) or 316-943-2351

## HORIZONTAL VENTING - 4" x 7"

	Description	Model Number
Horizontal Vent Termination Kits 	Rear Vent Hot Touch Termination Kit w/ 10" to 16" Adjustable Termination Pipe, Firestop, and Hot Touch Termination w/ Siding Shield	7TBRHTK
	Up and Out Side Wall Termination Kit w/ 10" to 16" Adjustable Termination Pipe, 90° Elbow, Firestop, and Cool Touch Termination w/ Siding Shield	7TDVSCTK
	Rear Vent Cool Touch Termination w/ Siding Shield for Straight-out Applications and Firestop - 8 pack	7TRVCT/8
	Rear Vent Hot Touch Termination w/ Siding Shield for Straight-out Applications and Firestop - 8 pack	7TRVHT/8
	Termination Guard for 7" T.L. Rear Vent Hot Touch Terminations (97TRVT/7TSVKT)	7TRVTG
	Snorkel Termination	7TDVSNORK
	7" T.L. DVRTSB Termination Screen Guard	7TBSG
	Up and Out Starter Kit w/ 40" Flex Pipe, Firestop, Cool Touch Termination w/ Siding Shield, and 2 ea. Clamp Bands	7FDVSCTK
Twist Lock Pipe 	20" Termination Pipe - 8 pack	7TDVP20/8
	10" - 16" Adjustable Termination Pipe - 4 pack	7TDVPA/4
	12" - 18" Adjustable Vent Length	7TDVP1218
	35" - 64" Adjustable Vent Length	7TDVP3564
	8" Vent Pipe - 4 pack	7TDVP8/4
	12" Vent Pipe - 4 pack	7TDVP12/4
	24" Vent Pipe - 4 pack	7TDVP24/4
	36" Vent Pipe	7TDVP36
	36" Vent Pipe - 30 pack	7TDVP36/30
	48" Vent Pipe	7TDVP48
	48" Vent Pipe - 30 pack	7TDVP48/30
	5" x 8" to 4" x 7" Adapter	7TDVP58
	Flex Adapter Starter Kit	DVFFA/8
Twist Lock Elbows 	45° Elbow for Vertical/Horizontal Offset	7TDV45
	45° Elbow for Vertical Offsets - 8 pack	7TDV45/8
	90° Elbow for Vertical/Horizontal Offset	7TDV90
	90° Elbow for Vertical/Horizontal Offset - 8 pack	7TDV90/8
Shields and Supports 	1" Firestop	7DV1FS
	3" Firestop	7DV3FS
	1" Attic Insulation Shield	7DV1AIS
	Combination Horizontal Offset/Roof Support	7DVCS



**VERTICAL VENTING - 4" x 7"**

	<b>Description</b>	<b>Model Number</b>
Vertical Vent Termination Kits 	Vertical Vent Termination w/ Storm Collar (flashing NOT included)	7TDVSKV
	Vertical Vent Termination w/ Storm Collar - 8 pack (flashing NOT included)	7TDVSKV/8
	Vertical Vent Termination w/ 1/12 - 6/12 Flashing, Storm Collar and Ceiling Support Kit	7TDVSKVA*
	Vertical Vent Termination w/ 6/12 - 12/12 Flashing, Storm Collar and Ceiling Support Kit	7TDVSKVB*
	Vertical Vent Termination w/ Flat Flashing, Storm Collar and Ceiling Support Kit	7TDVSKVF*
Twist Lock Pipe 	20" Rigid Pipe - single pack	7TDVP20
	30" Flex Pipe - single pack	7FDVP30
	12" - 18" Adjustable Vent Length	7TDVP1218
	35" - 64" Adjustable Vent Length	7TDVP3564
	8" Vent Pipe - 4 pack	7TDVP8/4
	12" Vent Pipe - 4 pack	7TDVP12/4
	24" Vent Pipe - 4 pack	7TDVP24/4
	36" Vent Pipe	7TDVP36
	36" Vent Pipe - 30 pack	7TDVP36/30
	48" Vent Pipe	7TDVP48
	48" Vent Pipe - 30 pack	7TDVP48/30
	5" x 8" to 4" x 7" Adapter	7TDVP58
Twist Lock Elbows 	45° Elbow for Vertical/Horizontal Offset	7TDV45
	45° Elbow for Vertical Offsets - 8 pack	7TDV45/8
	90° Elbow for Vertical/Horizontal Offset	7TDV90
	90° Elbow for Vertical/Horizontal Offset - 8 pack	7TDV90/8
Shields and Supports 	1" Firestop	7DV1FS
	1" Attic Insulation Shield	7DV1AIS
	Combination Horizontal Offset/Roof Support	7DVCS

## Massachusetts Residents Only — Please read and follow these special requirements

### NOTE REGARDING VENTED PRODUCTS

This product must be installed by a licensed plumber or gas fitter when installed within the Commonwealth of Massachusetts.

Any residence with a direct vent product must have a CO detector installed in the residence.

Installation of the fireplace or vented gas log in the State of Massachusetts requires the damper to be permanently removed or welded in the fully open position.

In addition, a naturally vented gas log may not be installed in a bedroom or bathroom in the State of Massachusetts.

Flex line installation must not exceed 36 inches and must have a T shutoff valve.

### NOTE REGARDING VENT FREE PRODUCTS

This product must be installed by a licensed plumber or gas fitter when installed within the Commonwealth of Massachusetts.

In addition, vent free products may not be installed in a bedroom or bathroom regardless of size or type in the State of Massachusetts.

Flex line installation must not exceed 36 inches and must have a T shutoff valve.

### CARBON MONOXIDE DETECTOR REQUIREMENTS

(2) Revise 10.8.3 by adding the following additional requirements:

(a) For all side wall horizontally vented gas fueled equipment installed in every dwelling, building or structure used in whole or in part for residential purposes, including those owned or operated by the Commonwealth and where the side wall exhaust vent termination is less than seven (7) feet above finished grade in the area of the venting, including but not limited to decks and porches, the following requirements shall be satisfied:

1. **Installation of carbon monoxide detectors.** At the time of installation of the side wall horizontal vented gas fueled equipment, the installing plumber or gas fitter shall observe that a hard wired carbon monoxide detector with an alarm and battery back-up is installed on the floor level where the gas equipment is to be installed. In addition, the installing plumber or gas fitter shall observe that a battery operated or hard wired carbon monoxide detector with an alarm is installed on each additional level of the dwelling, building or structure served by the side wall horizontal vented gas fueled equipment. It shall be the responsibility of the property owner to secure the services of qualified licensed professionals for the installation of hard wired carbon monoxide detectors

a. In the event that the side wall horizontally vented gas fueled equipment is installed in a crawl space or an attic, the hard wired carbon monoxide detector with alarm and battery back-up may be installed on the next adjacent floor level.

b. In the event that the requirements of this subdivision can not be met at the time of completion of installation, the owner shall have a period of thirty (30) days to comply with the above requirements; provided, however, that during said thirty (30) day period, a battery operated carbon monoxide detector with an alarm shall be installed.

2. **Approved Carbon Monoxide Detectors.** Each carbon monoxide detector as required in accordance with the above provisions shall comply with NFPA 720 and be ANSI/UL 2034 listed and IAS certified.

3. **Signage.** A metal or plastic identification plate shall be permanently mounted to the exterior of the building at a minimum height of eight (8) feet above grade directly in line with the exhaust vent terminal for the horizontally vented gas fueled heating appliance or equipment. The sign shall read, in print size no less than one-half (1/2) inch in size, "GAS VENT DIRECTLY BELOW. KEEP CLEAR OF ALL OBSTRUCTIONS."

4. **Inspection.** The state or local gas inspector of the side wall horizontally vented gas fueled equipment shall not approve the installation unless, upon inspection, the inspector observes carbon monoxide detectors and signage installed in accordance with the provisions of 248 CMR 5.08(2)(a)1 through 4.

(b) **Exemptions:** The following equipment is exempt from 248 CMR 5.08(2)(a)1 through 4:

1. The equipment listed in Chapter 10 entitled "Equipment Not Required To Be Vented" in the most current edition of NFPA 54 as adopted by the Board; and

2. Product Approved side wall horizontally vented gas fueled equipment installed in a room or structure separate from the dwelling, building or structure used in whole or in part for residential purposes.

(c) **Manufacturer requirements — Gas Equipment Venting System Provided.** When the manufacturer of Product Approved side wall horizontally vented gas equipment provides a venting system design or venting system components with the equipment, the instructions provided by the manufacturer for installation of the equipment and the venting system shall include:

1. Detailed instructions for the installation of the venting system design or the venting system components; and

2. A complete parts list for the venting system design or venting system.

(d) **Manufacturer requirements — Gas Equipment Venting System Not Provided.** When the manufacturer of a Product Approved side wall horizontally vented gas fueled equipment does not provide the parts for venting the flue gases, but identifies "special venting systems," the following requirements shall be satisfied by the manufacturer:

1. The referenced "special venting system" instructions shall be included with the appliance or equipment installation instructions; and

2. The "special venting systems" shall be Product Approved by the Board, and the instructions for that system shall include a parts list and detailed installation instructions.

(e) A copy of all installation instructions for all Product Approved side wall horizontally vented gas fueled equipment, all venting instructions, all parts lists for venting instructions, and/or all venting design

# LIMITED LIFETIME WARRANTY POLICY

## LIFETIME WARRANTY

The following components are warranted for life to the original owner, subject to proof of purchase: Firebox, Combustion Chamber, Heat Exchanger, Grate and Stainless Steel Burners.

## FIVE YEAR WARRANTY

The following components are warranted five (5) years to the original owner, subject of proof of purchase: Ceramic Fiber Logs.

## BASIC WARRANTY

MHSC warrants the components and materials in your gas appliance to be free from manufacturing and material defects for a period of two years from date of installation. After installation, if any of the components manufactured by MHSC in the appliance are found to be defective in materials or workmanship, MHSC will, at its option, replace or repair the defective components at no charge to the original owner. MHSC will also pay for reasonable labor costs incurred in replacing or repairing such components for a period of two years from date of installation. Any products presented for warranty repair must be accompanied by a dated proof of purchase.

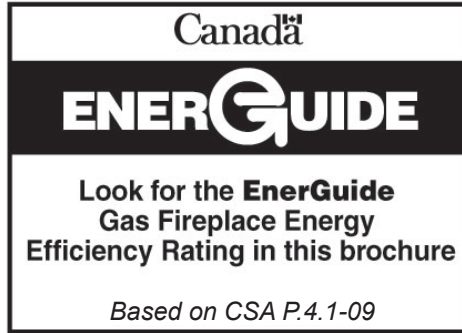
This Limited Lifetime Warranty will be void if the appliance is not installed by a qualified installer in accordance with the installation instructions. The Limited Lifetime Warranty will also be void if the appliance is not operated and maintained according to the operating instructions supplied with the appliance, and does not extend to (1) firebox/burner assembly damage by accident, neglect, misuse, abuse, alterations, negligence of others, including the installation thereof by unqualified installers, (2) the costs of removal, reinstallation or transportation of defective parts on the appliance, or (3) incidental or consequential damage. All service work must be performed by an authorized service representative.

This warranty is expressly in lieu of other warranties, express or implied, including the warranty of merchantability of fitness for purpose and of all other obligations or liabilities. MHSC does not assume for it any other obligations or liabilities in connection with sale or use of the appliance. It states that do not allow limitations on how long an implied warranty lasts, or do not allow exclusion of indirect damage, those limitations of exclusions may not apply to you. You may also have additional rights not covered in the Limited Lifetime Warranty.

MHSC reserves the right to investigate any and all the claims against the Limited Lifetime Warranty and decide upon method of settlement.

## IF WARRANTY SERVICE IS NEEDED...

1. Contact your supplier. Make sure you have your warranty, your sales receipt and the model/serial number of your MHSC product.
2. DO NOT ATTEMPT TO DO ANY SERVICE WORK YOURSELF.



<b>Efficiency Ratings</b>		
<b>Model</b>	<b>EnerGuide Ratings Fireplace Efficiency (%)</b>	<b>D.O.E. (AFUE%)</b>
MLDV500NV	70.5	67.1
MLDV500PV	76.4	67.3

**MHSC**

149 Cleveland Drive • Paris, Kentucky 40361  
www.mhsc.com