



1-800-968-8604

*Extinguishing mediocrity online since 1999*



FIRESTAR

OUTDOOR FIRE PIT



*Traditional*  
Fireplace  
Design Collection

TRULY

TIMELESS

astria  
FIREPLACES™





*FEATURED Firestar Fire Pit with LedgeStone blocks*

## **FIRESTAR**

Outdoor rooms have become increasingly popular and no deck or patio would be complete without a fire to gather around. The Firestar Fire Pit is an authentic masonry 48” diameter fire pit which can be paired with your choice of burner and lava rock ember bed.



*Concealed Fire Pit controls*



*Chiseled Face Stone*



*Ledgestone*

## EXCLUSIVE FEATURES

- ◆ 48" fire ring with smooth stone cap
- ◆ Available in two heights : two tier (17-1/8") and three tier (24-1/4")
- ◆ Battery operated electronic ignition controls concealed in waterproof compartment
- ◆ Stainless steel or black aluminized star burner with center flame pod
- ◆ Includes decorative lava rock media
- ◆ Choose from Chiseled Stone Face or Ledgestone blocks
- ◆ Easy access control compartment with matching face block and pull ring
- ◆ Dry stacked or field grouted construction
- ◆ 3 Year Limited Warranty

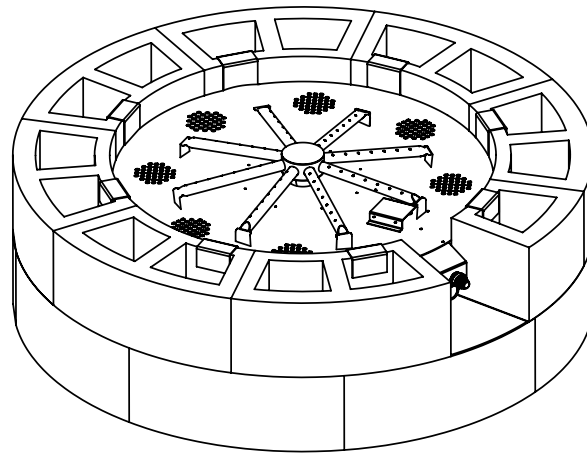
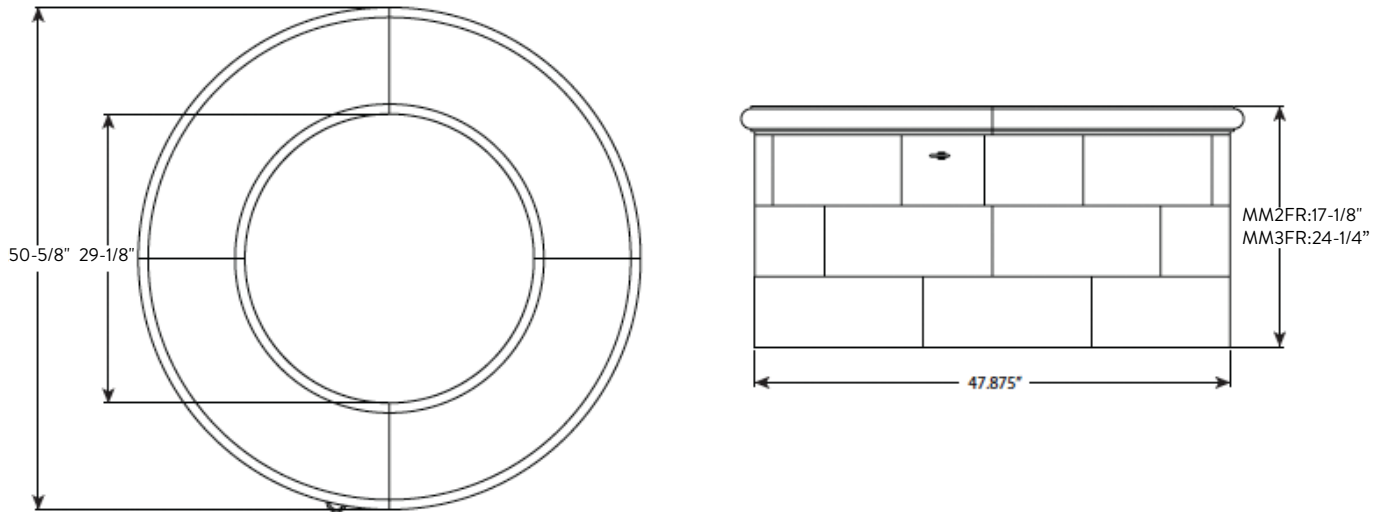

Star burner

**IMPORTANT NOTES:**

As with any heating appliance, this appliance is extremely hot during operation. Read and understand all operating instructions before using this appliance. For further information, consult your dealer.

Local conditions, such as elevation, wind, vent configuration and choice of fuel will affect overall appearance of the fire and heating performance. Performance can also vary with home design and insulation, climate, condition and type of fuel used, appliance location, burn rate, accessories chosen, chimney installation and how the appliance is operated.

Diagrams, illustrations and photographs are not to scale—consult installation instructions. Product designs, materials, dimensions, specifications, colors and prices are subject to change or discontinuance without notice.

**APPLIANCE BTU OPERATING INPUT**

MODEL	FUEL	BTU/HR
FIRESTAR	NG	96,000
FIRESTAR	LP	95,000



Visit us online



Astria.us.com

