

# NAPOLEON



**HIGH EFFICIENCY THRU WALL  
SELF CONTAINED HEATING &  
COOLING UNITS**

**- HIGH EFFICIENCY -  
CONDENSING GAS FURNACE  
UP TO 10.8 EER AIR CONDITIONING**



[napoleonheatingandcooling.com](http://napoleonheatingandcooling.com)



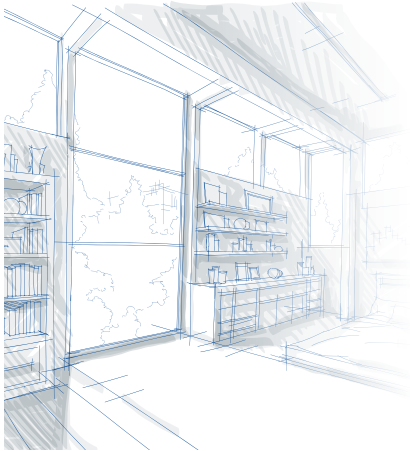

ARCHITECTURALLY INSPIRED. PROUDLY ENGINEERED & MADE IN CANADA.

## ENERGY SAVINGS AND COMFORT

We've reinvented high efficiency. Designed for conventional thru wall installation applications, Condo Pack is the most effective choice with an 'all indoor design' for a clean exterior look. Perfect for residential low and high rise applications as well as institutional and industrial installations.

Napoleon's streamlined design is an aesthetically pleasing solution for your unique architectural needs. By removing exterior equipment and refrigerant connections from your application, your next installation will benefit with the added protection from extreme climate conditions and unforeseen damage. Pre-wired and pre-charged, our dual unit slide out chassis allows for easy installation and maintenance of both heating and cooling units. Our industry leading quality control program ensures years of trouble free use for your peace of mind.

## EASY INSTALLATION AND MAINTENANCE ADVANTAGES

- Furnace efficiency up to 93% AFUE and 90% thermal efficiency
- Tubular stainless steel primary and secondary heat exchanger
- Up to 10.8 EER with R-410A refrigerant
- Natural gas or propane, direct vent
- Blower dynamically balanced with resilient motor mounts for noise reduction & smooth operation
- Independent metering & temperature control
- Direct vent design eliminates the need for a chimney
- Exterior condensate drain for ease of service
- Fully insulated cabinet for clean & quiet operation
- Three piece design allows for individual component handling for easy installation and serviceability
- Wall sleeve (optional) can be installed separately during building framing, for easier and cleaner installation
- Entire unit is factory tested before shipment

### MODULAR DESIGN

#### HEATING MODULE



##### GAS FIRED

30,000 BTU/H

40,000 BTU/H

50,000 BTU/H

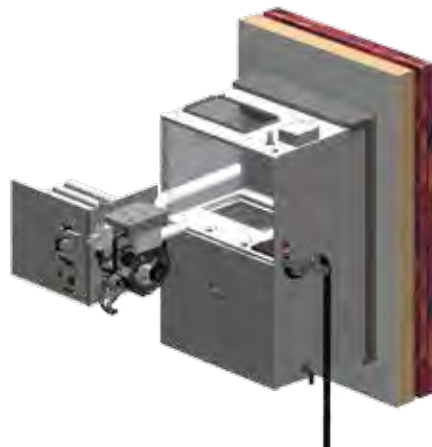

#### COOLING MODULE



##### COOLING

1.0 TON

1.5 TON

2.0 TON

2.5 TON



## BENEFITS OF MICRO-CHANNEL CONDENSERS

- 20 - 30% weight reduction
- 50% reduced refrigerant charge
- Improved air-flow
- Fan noise reduction
- More durable design
- Improved serviceability
- Easier to maintain and clean than spin fin or tube fin designs



## SERVICE ADVANTAGES

- Indoor access to all parts & maintenance needs
- Innovative, dual slide out chassis for efficient service
- Both sections can be partially or fully removed for servicing
- With spare modules, building management can do quick swap outs to maintain climate in the apartment/condo while troubleshooting non functioning units off line
- Can do direct replacement of the individual modules at the end of their service life instead of the complete appliance
- All control harnesses are separated with modular quick disconnects so module swap outs do not require time consuming rewiring

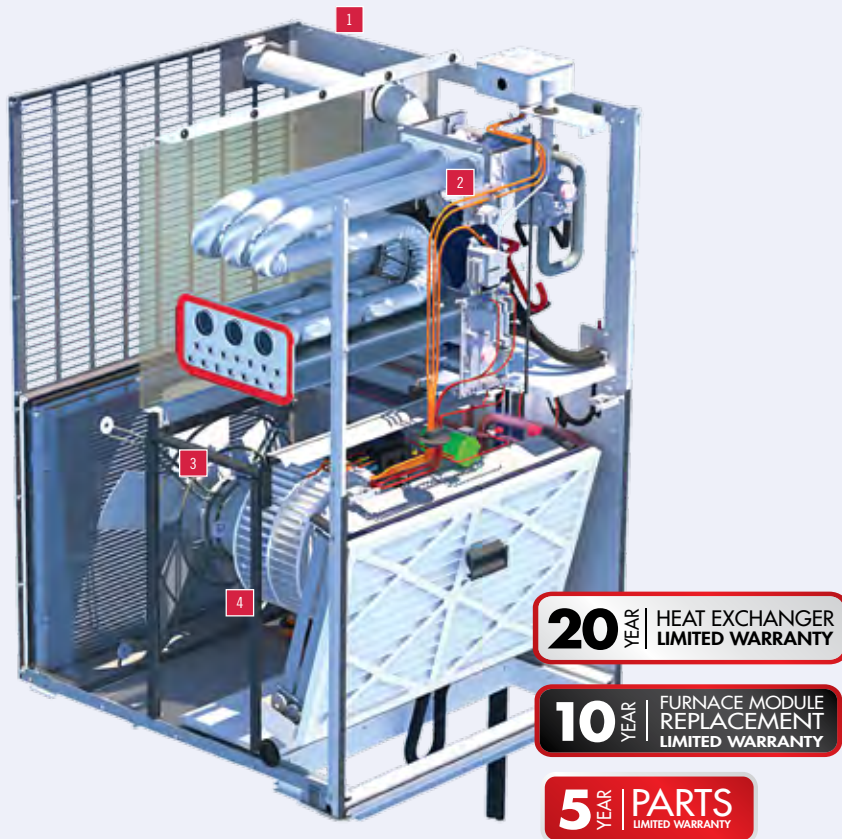

### 1. Compatible Box Size

- Industry standard footprint for retrofit applications
- Appliance shell dimensions where penetrating exterior wall: 43 1/8" high X 28" wide
- Wall Sleeve dimensions: 44 7/8" high X 28 7/8" wide
- Total length: 32"

### 2. Heating Features

- Up to 93% AFUE and 90% thermal efficiency
- High Efficiency Condensing Single Stage Gas Furnace
- Stainless steel heat exchanger
- Sealed burner tray – keeps cold external air from circulating in vestibule
- Clear front manifold condensate cover for easy inspection and service trouble shooting

### 3. Cooling Features

- Up to 10.8 EER
- R-410A Refrigerant system
- Micro-channel condenser and evaporator coils

### 4. Circulation Blower

- Dual inlet blower for higher flow rates / reduced air noise
- X-13 Multi-Speed Electronically Commutated Motor for better electrical efficiency



\*See warranty for details



# INSTALLATION DIMENSIONS

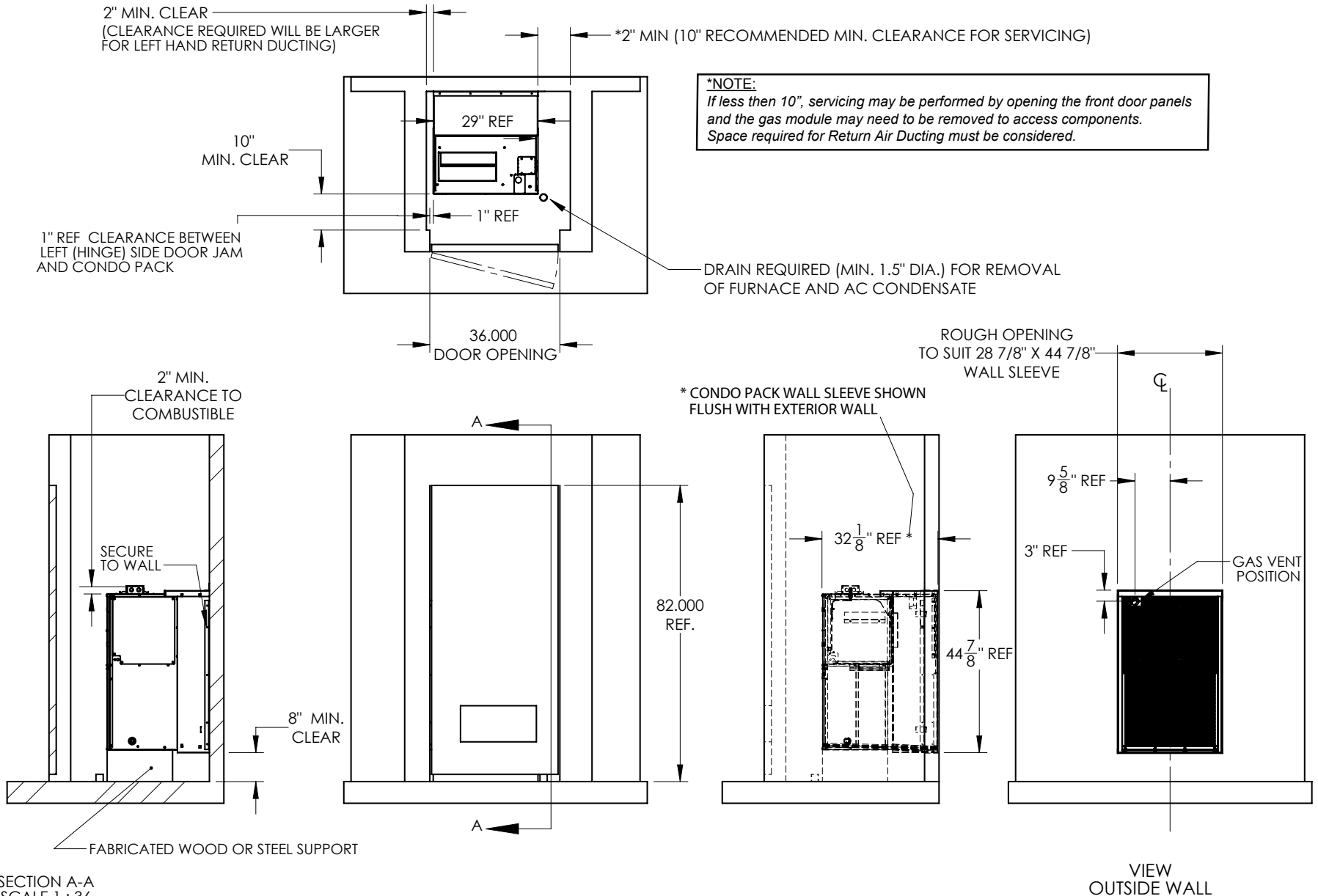

# UNIT DIMENSIONS

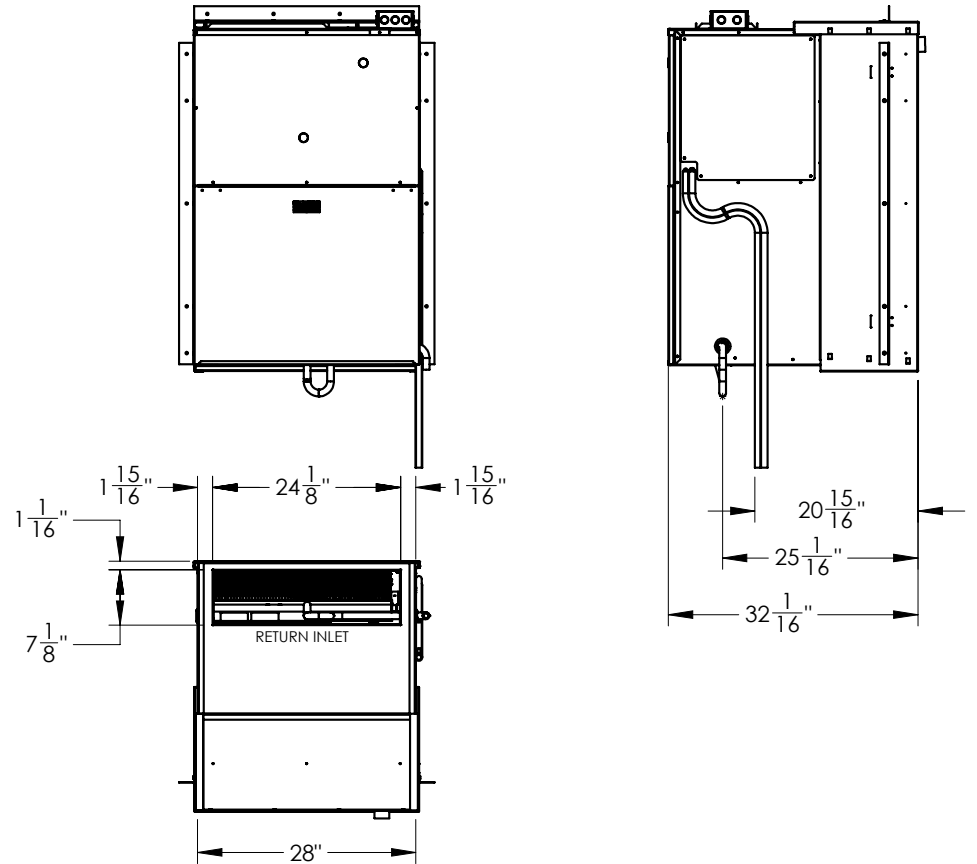
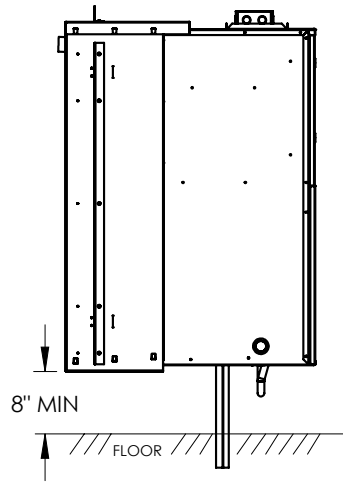
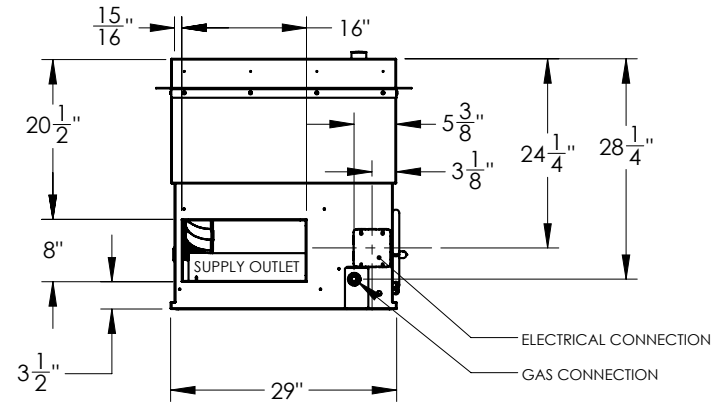
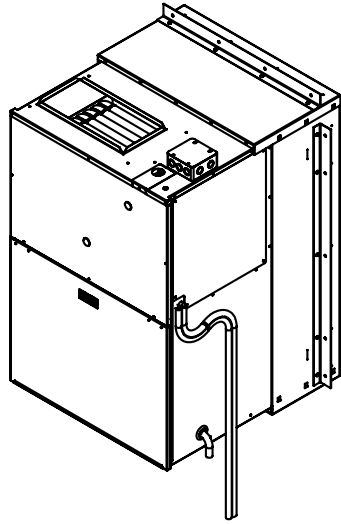

# WALL SLEEVE

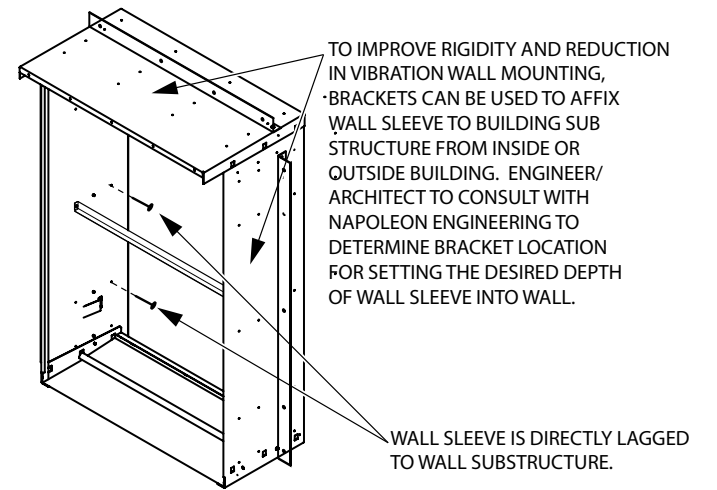
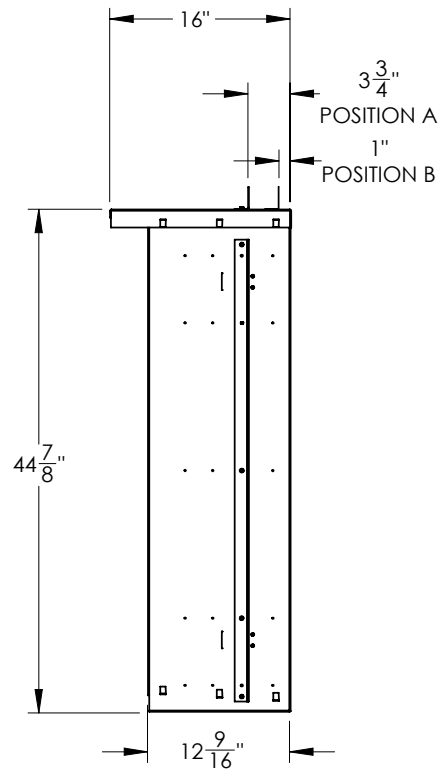
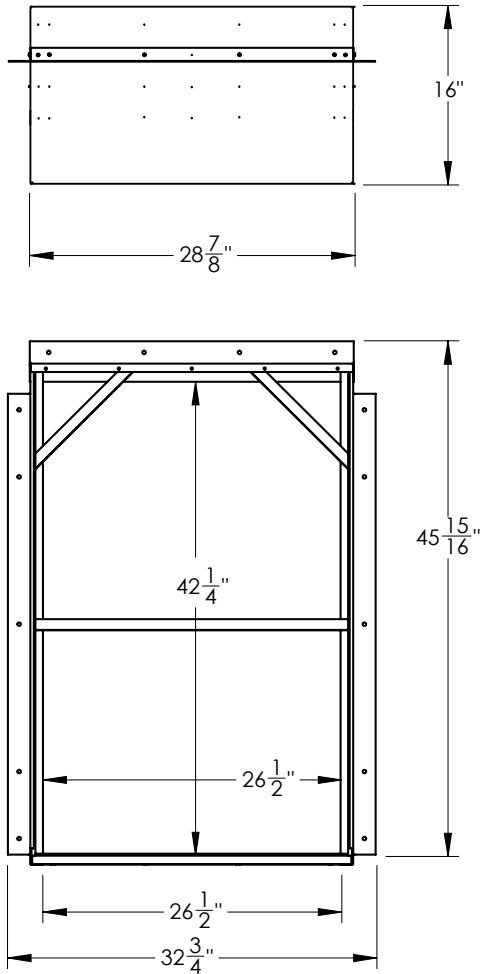

## SPECIFICATIONS

HEATING CAPACITIES	PSC030A012A	PSC030A018A	PSC030A024A	PSC030A030A	PSC040A012A	PSC040A018A	PSC040A024A	PSC040A030A	PSC050A012A	PSC050A018A	PSC050A024A	PSC050A030A
Thermal Efficiency	90%	90%	90%	90%	90%	90%	90%	90%	90%	90%	90%	90%
AFUE Efficiency	93%	93%	93%	93%	91.7%	91.7%	91.7%	91.7%	90.6%	90.6%	90.6%	90.6%
Input BTU/hr	30,000	30,000	30,000	30,000	40,000	40,000	40,000	40,000	50,000	50,000	50,000	50,000
Output BTU/hr	27,900	27,900	27,900	27,900	36,680	36,680	36,680	36,680	45,300	45,300	45,300	45,300
COOLING CAPACITIES	PSC030A012A	PSC030A018A	PSC030A024A	PSC030A030A	PSC040A012A	PSC040A018A	PSC040A024A	PSC040A030A	PSC050A012A	PSC050A018A	PSC050A024A	PSC050A030A
BTU/hr	12,800	16,500	19,500	24,400	12,800	16,500	19,500	24,400	12,800	16,500	19,500	24,400
EER	10.8	9.6	9.0	9.0	10.8	9.6	9.0	9.0	10.8	9.6	9.0	9.0
REF.	410A	410A	410A	410A	410A	410A	410A	410A	410A	410A	410A	410A

		CFM AT EXTERNAL STATIC PRESSURE, INCHES WATER COLUMN										
HEATING	SETTING	0.1	0.2	0.3	0.4	0.5	0.6	0.7	0.8	0.9	1.0	
30 kBTU/H	Factory	569	529	494	470	415	368	346	306	273	-	
	High	771	744	729	704	693	663	644	610	566	556	
40 kBTU/H	Factory	771	744	729	704	693	663	644	610	566	556	
	High	924	908	886	868	839	804	757	696	617	-	
50 kBTU/H	Factory	924	908	886	868	839	804	757	696	617	-	
	High	1010	971	938	906	870	824	773	713	617	-	
COOLING	SETTING											
1 TON	Factory	439	388	333	294	240	193	-	-	-	-	
	High	569	529	494	470	415	368	346	306	273	-	
1.5 TON	Factory	771	744	729	704	693	663	644	610	566	556	
	High	924	908	886	868	839	804	757	696	617	-	
2.0 TON	Factory	771	744	729	704	693	663	644	610	566	556	
	High	924	908	886	868	839	804	757	696	617	-	
2.5 TON	Factory	1010	971	938	906	870	824	773	713	617	-	

DESCRIPTION	1.0 TON	1.5 TON	2.0 TON	2.5 TON
Compressor Type	Rotary	Scroll	Scroll	Scroll
Rated Amps	5.5	9	13.5	12.8
LRA	26	48	58.3	64
MCA	10.7	15.1	20.7	20.3
Max Fuse/Breaker (A)	15	20	30	30
Indoor Fan FLA / HP / RPM	2.8 / 1/3 / 1050	2.8 / 1/3 / 1050	2.8 / 1/3 / 1050	2.8 / 1/3 / 1050
Condenser Fan FLA / HP / RPM	1.0 / 1/6 / 1075	1.0 / 1/6 / 1075	1.0 / 1/6 / 1075	1.5 / 1/4 / 1075
Combustion Fan FLA	1.25	1.25	1.25	1.25

Condo Pack module options include:

- Gas Furnace - High Efficiency
- Electric
- Duct Only
- Gas Furnace - Mid Efficiency
- Heat Pump
- Blower Only
- Air Conditioner
- Hydronic

For more information about available products, contact your sales representative.



Custom color options are available. Standard color options are Taupe (colour code TP) and Silk Grey (colour code SG).

Other Napoleon Products



Fireplace Inserts • Gas Furnaces • Gas Fireplaces • Mantels • Wood Stoves  
 Charcoal Grills • Electric Fireplaces • Outdoor Fireplaces • Gas Grills

Authorized Dealer



24 Napoleon Road, Barrie, Ontario, Canada L4M 0G8  
 103 Miller Drive, Crittenden, Kentucky, USA 41030  
 7200 Trans Canada Highway, Montreal, Quebec, Canada H4T 1A3

Tel: 866-820-8686 Fax: 705-725-1150  
[napoleonheatingandcooling.com](http://napoleonheatingandcooling.com)



All specifications and designs can change without notice to allow for on-going product improvement. Images may not be exactly as shown. Consult your owners manual for current information. Check all local and national building codes and gas regulations. Napoleon is a registered trademark of Wolf Steel Ltd. © Wolf Steel Ltd.





**Obadiah's**

**1-800-968-8604**

---

**WOODSTOVES**

*Serving you online since 1999*