



SENTINEL

DIRECT VENT GAS FIREPLACES



Traditional
Fireplace
Design Collection

TRULY

TIMELESS

astria
FIREPLACES™



FEATURED Sentinel shown with White Split Herringbone Refractory Panels

SENTINEL

The Sentinel Series direct vent gas fireplaces deliver a true louverless design featuring one of the tallest viewing areas, realistic fire and a true masonry-built look. Combined with a large variety of options, the Sentinel Series will create a warm and inviting feeling in your home.



FEATURED Sentinel shown with Red Split Herringbone Panels

Options

INTERIOR (REQUIRED)

Choose from four realistic refractory panels that deliver the true look of masonry craftsmanship.



White Split Herringbone



White Split Stacked



Red Split Herringbone



Red Split Stacked

PERIMETER TRIM KITS (OPTIONAL)

Choose from two realistic Refractory Perimeter Trims to add the finishing touch to your new fireplace.



White Split Stacked Perimeter Trim Kit



White Split Stacked



Red Split Stacked

EXCLUSIVE FEATURES

- ◆ Available in 36" and 42" models
- ◆ Conveniently located gas controls for easy installation and operation
- ◆ Energy saving electronic controls with seamless battery backup provide continued operation in the event of a power outage
- ◆ Clean-face design allows more flexibility for a custom look
- ◆ Tall opening provides an exceptional view of the flame
- ◆ Multi-level burner produces tall, dancing flames with beautiful ember bed
- ◆ Standard tempered glass
- ◆ Ceramic fiber log set with cast-iron grate
- ◆ High definition refractory panels available in multiple styles and colors
- ◆ Optional, easy to install matching perimeter trim hides the glass door frame to achieve a true masonry appearance
- ◆ Includes on/off remote control
- ◆ Limited Lifetime Warranty



Remote included

APPLIANCE SPECIFICATIONS

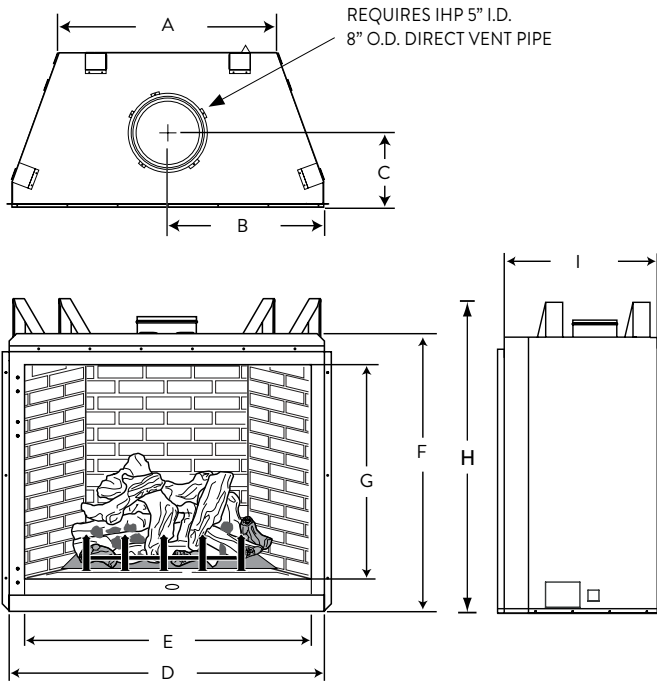

SENTINEL 36 **SENTINEL 42**

A	29-1/8"	34-3/4"
B	20-1/2"	24-1/8"
C	11-7/8"	13-5/8"
D	41"	48"
E	35"	42"
F	38-7/8"	42-7/8"
G	30-7/8"	34-7/8"
H	43"	47"
I	21-1/8"	25-1/8"

FIREPLACE EFFICIENCIES

MODEL	FUEL	BTU/HR	P4 / ENERGUIDE*
SENTINEL 36	NG	33,500	34.35%
SENTINEL 36	LP	31,000	32.45%
SENTINEL 42	NG	41,000	24.67%
SENTINEL 42	LP	37,000	22.79%

*Intermittent ignition systems.

IMPORTANT NOTES:

As with any fireplace, this appliance is extremely hot during operation. Read and understand all operating instructions before using this appliance. For further information, consult your dealer.

Local conditions, such as elevation, wind, vent configuration and choice of fuel will affect overall appearance of the fire and heating performance. Performance can also vary with home design and insulation, climate, condition and type of fuel used, appliance location, burn rate, accessories chosen, chimney installation and how the appliance is operated.

Diagrams, illustrations and photographs are not to scale—consult installation instructions. Product designs, materials, dimensions, specifications, colors and prices are subject to change or discontinuance without notice.

FLAT WALL FRAMING SPECIFICATIONS

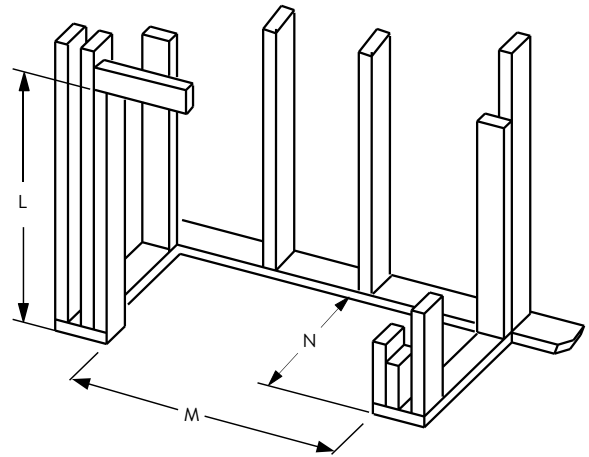

SENTINEL 36 **SENTINEL 42**

L	44"	48"
M	41-1/2"	48-1/2"
N	22"	26"

CORNER FRAMING SPECIFICATIONS

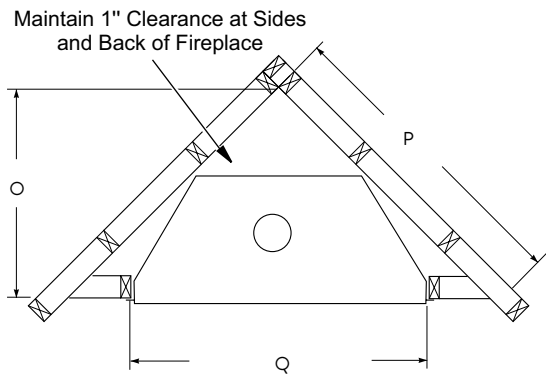

SENTINEL 36 **SENTINEL 42**

O	36-3/8"	43-3/8"
P	51-3/8"	61-3/4"
Q	41-1/2"	48-1/2"



Approved for use with European Copper and Chimney Classics chimney tops, which improve performance and add an elegant touch.

astria
FIREPLACES™



Visit us online



Astria.us.com

© 2014 Innovative Hearth Products
785564M 08/14

